

1
2
3
4
5
6
7
8
9
10
11
12
13
14
15
16
17
18
19
20
21
22
23
24
25
26
27
28
29
30
31
32
33

ORDINANCE NO. **11187**

AN ORDINANCE approving and adopting the "King County Road Standards", 1993 update, as the standards for road design in King County, amending Ordinance No. 8041, Sections 4 and 6, and K.C.C. 14.42.030 and 14.42.050, and repealing and replacing Ordinance No. 8041, Sections 2 and 10 and K.C.C. 14.42.010 and 14.42.090.

PREAMBLE: The King County Road Standards were last adopted in their entirety by King County Ordinance 8041 dated April 27, 1987. The proposed new publication "King County Road Standards" updates the 1987 document. These standards update, clarify and correct portions of the previous road standards. These changes are intended to support and be part of the county's goals regarding growth management, housing and sensitive areas.

BE IT ORDAINED BY THE COUNCIL OF KING COUNTY:

SECTION 1. Ordinance No. 8041, Section 2, as amended and K.C.C. 14.42.010 are hereby repealed and the following is substituted.

Adoption. A. "King County Road Standards", 1993 update, as amended by the council December 20, 1993, incorporated herein as Attachment A with amended Sections 2.03, 2.20, 2.21, 3.02, 5.03 and 5.10 as Attachment B are hereby approved and adopted as the King County standards for road design and construction.

B. Consistent with council's direction and intent in adopting these standards the department of public works is hereby authorized to develop public rules and make minor changes to the drawings in order to better implement the standards and as needed to stay current with changing design and construction technology and methods.

C. Consistent with council's direction and intent in adopting these standards the department of public works will establish a committee consisting of county staff and representatives of the fire and emergency medical service and development communities. The committee will investigate alternative roadway widths and other road standard related issues that impact the ability to provide emergency fire and medical service to the public and report findings back to council by September 1994.

SECTION 2. Ordinance No. 8041, Section 4 and K.C.C. 14.42.030 are hereby amended to read as follows:

1
2
3
4
5
6
7
8
9
10
11
12
13
14
15
16
17
18
19
20
21
22
23
24
25
26
27
28
29
30
31
32
33

Applicability. A. The standards may apply to all newly constructed modifications of roadway features or existing facilities which are within the scope of reconstructions or capital improvement projects when so required by King County or to the extent they are expressly referred to in project plans and specifications. These standards are not intended to apply to "resurfacing, restoration and rehabilitation" projects as those terms are defined in the Local Agency Guidelines, Washington State Department of Transportation, as amended; however, the engineer may in his discretion consider the standards as optional goals.

B. The standards shall apply to every new placement and every planned, non-emergency replacement of utility poles and other utility structures within King County right-of-way.

SECTION 3. Ordinance No. 8041, Section 6 and K.C.C. 14.42.050 are hereby amended as follows:

References. The standards implement and are intended to be consistent with the references listed in Section 1.04 of Attachment A, "King County Road Standards, ((1986)) 1993".

SECTION 4. Ordinance No. 8041, Section 10 and K.C.C. 14.42.090 are hereby repealed and the following is substituted:

11187

1 Effective Date. This ordinance shall take effect (30) days from its
2 enactment.

3 INTRODUCED AND READ for the first time this 7th day of
4 September, 1993.

5 PASSED this 20th day of December 1993.

6 KING COUNTY COUNCIL
7 KING COUNTY, WASHINGTON

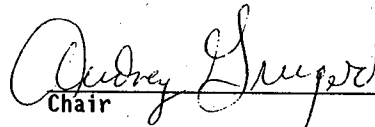
8
9 
10 Chair

11 ATTEST:

12 
13 Clerk of the Council

14 APPROVED this 30th day of DECEMBER, 1993.

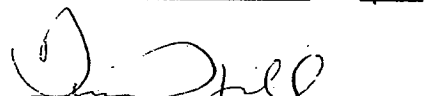
15
16 
17 King County Executive

18 WP:es/standard.ord

19 Attachment: A. King County Road Standards, 1993
20 B. Attachment B

1
2
3
4
5
6
7
8
9
10
11
12
13
14
15
16
17
18
19
20
21
22
23
24
25
26
27
28
29
30
31
32
33

Department of Public Works
Louis J. Haff, P.E., County Road Engineer

King County Road Standards - 1993

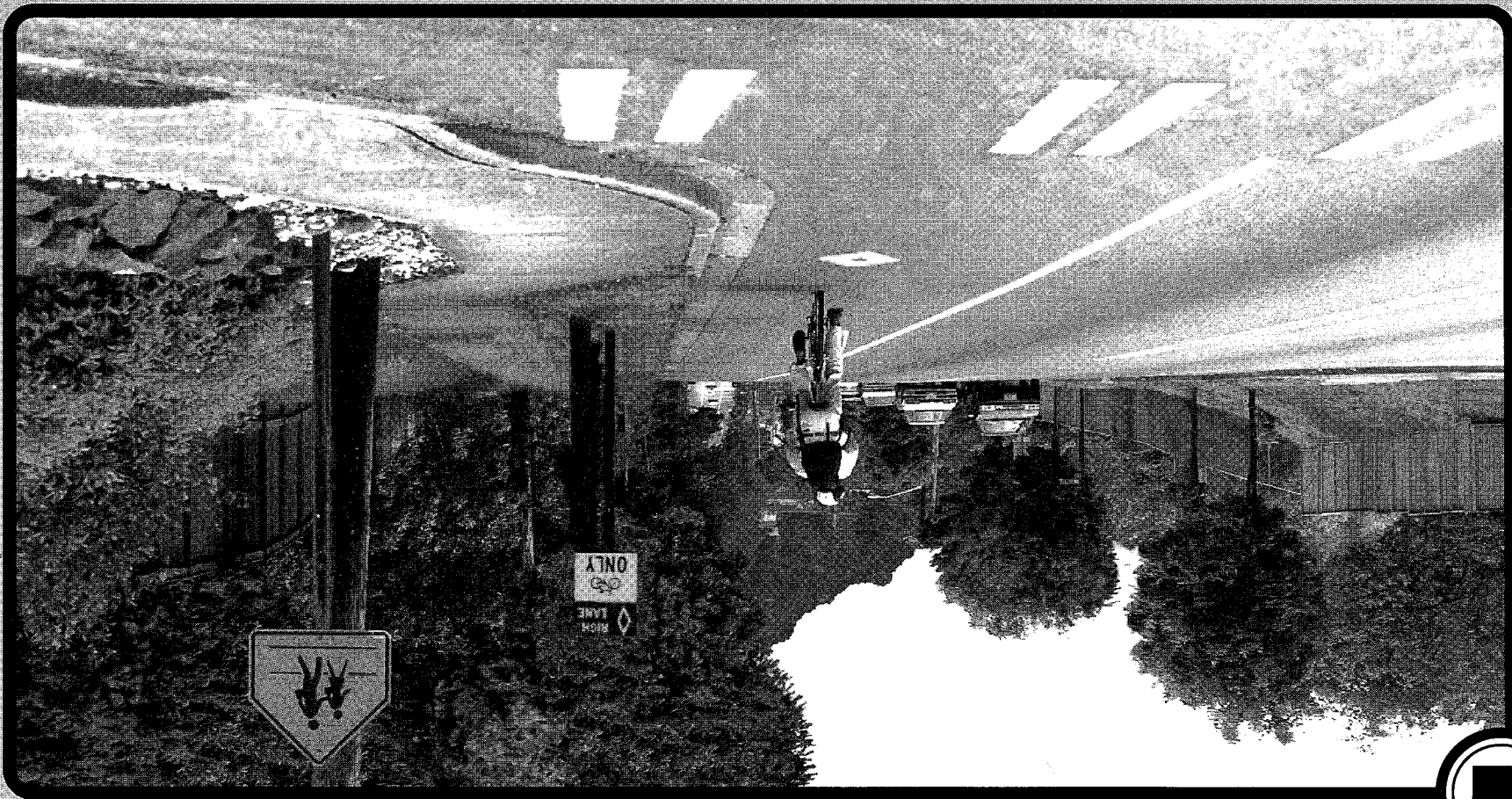

KING COUNTY ROAD STANDARDS 1993

TABLE OF CONTENTS

PURPOSE

CHAPTER 1. GENERAL CONSIDERATIONS

1.01	Shortened Designation	2
1.02	Applicability	2
1.03	Responsibility to Provide Roadway Improvements	2
1.04	General References	3
1.05	WSDOT/APWA Documents as Primary Design and Construction References	4
1.06	Other Specifications	4
1.07	Road Plans	4
1.08	Variances	5
1.09	Penalties and Financial Guarantees	6
1.10	Meaning of Terms	6
1.11	Severability	8

CHAPTER 2. ROAD TYPES & GEOMETRICS

2.01	Road Classifications	9
2.02	Arterial Roads	10
2.03	Residential Access Streets	11
2.04	Commercial Access Streets	12
2.05	Horizontal Curvature and Sight Distance Design Values	13
2.06	Private Streets	14
2.07	Half Streets	15
2.08	Cul-de-sacs and Eyebrows	16
2.09	Alleys and Private Access Tracts	17
2.10	Intersections and Low Speed Curves	18
2.11	Maximum Grade and Grade Transitions	19
2.12	Stopping Sight Distance	19
2.13	Entering Sight Distance	20
2.14	Medians	20
2.15	One-Way Streets	21
2.16	Bus Zones and Turn-Outs	21
2.17	Exception to Paving on Rural Minor Access Streets (Residential)	21
2.18	Intersections with State or Federal Highways	21
2.19	Slope, Wall, & Drainage Easements and Right-of-Way Reduction	22

TABLE OF CONTENTS (Continued)

2.20	Access and Circulation Requirements	22
2.21	Exception for Maximum Dwelling Units on Urban Subcollectors	23

CHAPTER 3. DRIVEWAYS, WALKS, & TRAILS

3.01	Driveways	24
3.02	Concrete Sidewalks	26
3.03	Curbs, Gutters and Sidewalks	27
3.04	Expansion and Dummy Joints	27
3.05	Curb Ramps	28
3.06	Concrete Steps, Metal Handrail and Handicapped Access Ramps	28
3.07	Asphalt Shoulders	28
3.08	Separated Walkways, Bikeways and Trails	29
3.09	School Access	29
3.10	Bikeways	29
3.11	Equestrian Facilities	30

CHAPTER 4. SURFACING

4.01	Residential Streets, Pedestrian and Bike	32
4.02	Requirements for Residential Streets on Poor Subgrade	34
4.03	Arterials and Commercial Access Streets	34
4.04	Materials & Lay-Down Procedures	34
4.05	Pavement Markings, Markers, and Pavement Tapers	35

CHAPTER 5. ROADSIDE FEATURES

5.01	Rock Facings	37
5.02	Side Slopes	39
5.03	Street Trees & Landscaping	39
5.04	Mail Boxes	39
5.05	Street Illumination	41
5.06	Survey Monuments	41
5.07	Roadway Barricades	41
5.08	Bollards	42
5.09	Guardrail/Embankment Heights	42
5.10	Off-Street Parking Spaces	42
5.11	Roadside Obstacles	42

TABLE OF CONTENTS (Continued)

CHAPTER 6. BRIDGES

6.01	Principal References	44
6.02	Bridge Geometrics	44
6.03	Bridge Design Criteria	44
6.04	Special Permits	45

CHAPTER 7. DRAINAGE

7.01	General	46
7.02	Road Ditches	46
7.03	Storm Sewers and Culverts	47
7.04	Catch Basins and Junctions	48
7.05	Frames, Grates, and Covers	49
7.06	Erosion Control	50
7.07	Trenches	50

CHAPTER 8. UTILITIES

8.01	Franchising Policy and Permit Procedure	51
8.02	Standard Utility Locations Within the Right-of-Way	51
8.03	Underground Utility Installation	54
8.04	Final Utility Adjustment (To Finish Grade)	57
8.05	Final Cleanup, Restoration of Surface Drainage and Erosion Control	58

CHAPTER 9. CONSTRUCTION CONTROL AND INSPECTION

9.01	Basis for Control of the Work	59
9.02	Subdivision, Commercial and Right-Of-Way Land Use Inspection	59
9.03	Penalties for Failure to Notify for Land Use Inspection	60
9.04	Embankment Construction Control in Developments	61
9.05	Traffic Control in Development Construction	61
9.06	County Forces and County Contract Road Inspection	62
9.07	Call Before You Dig	62

TABLE OF CONTENTS (Continued)

DRAWINGS

SECTION 1-000 ROADWAY

<u>Drawing Number</u>	<u>Drawing Title</u>	
1-001	Shoulder Type Roadway	65
1-002	Vertical Curb Type Roadway	66
1-003	Rolled Curb Type Roadway	67
1-004	Gravel Surface Roadway	68
1-005	Thickened Edge Roadway	69
1-006	Extruded Curb Roadway	70
1-007	Cul-de-Sacs	71
1-008	Temporary Cul-de-Sac	72
1-009	Eyebrow	73
1-010	Half Street	74
1-011	Alley Pavement Detail	75

SECTION 2-000 DRAINAGE

<u>Drawing Number</u>	<u>Drawing Title</u>	
2-001	Beveled End Pipe Section	76
2-002	Field Tapping of Concrete Pipe	77
2-003	Catch Basin Type 1	78
2-004	Catch Basin Type 1-L	79
2-005	Catch Basin Type 2 - 48", 52", 60", 72" & 96"	80
2-006	Catch Basin Details	81
2-007	Manhole Type 1 - 48", 52" & 60"	82
2-008	Manhole Type 2 - 72" & 96"	83
2-009	Manhole Type 3 - 48", 52", 60", 72" & 96"	84
2-010	Manhole Type 4	85
2-011	Manhole Details	86
2-012	Curb Inlet	87
2-013	Standard Grate	88
2-014	Standard Frame with Vertical Curb Installation	89
2-015	Solid Cover	90
2-016	Through-curb Inlet Frame	91
2-017	Through-curb Inlet Frame and Grate with Vertical Curb Installation	92
2-018	Vaned Grate	93

TABLE OF CONTENTS (Continued)

<u>Drawing Number</u>	<u>Drawing Title</u>	
2-019	Rolled Curb Frame and Grate	94
2-020	Rolled Curb Frame and Grate Installation	95
2-021	Rolled Curb Vaned Grate	96
2-022	Locking Manhole Cover	97
2-023	Locking Manhole Frame	98
2-024	Rock-lined Shoulder Ditches & Curbed or Turnpike Shoulders	99
2-025	Flow Restrictor/Oil Pollution Control Device, Tee Type (FROP-T)	100
2-026	FROP-T Shear Gate Detail	101
2-027	Flow Restrictor/Oil Pollution Control Device, Baffle Type (FROP-B)	102
2-028	Debris Cage	103

SECTION 3-000 CURB & DRIVEWAY

<u>Drawing Number</u>	<u>Drawing Title</u>	
3-001	Curb and Sidewalk Joints	104
3-002	Curb Details	105
3-003	Shoulder and Ditch Section Driveway	106
3-004	Curb and Gutter Section Driveway	107
3-005	Reverse Slope Driveway	108
3-006	Location and Width of New Driveways	109
3-007	Joint Use Driveway Tract	110

SECTION 4-000 SIDEWALKS & CURB RAMPS

<u>Drawing Number</u>	<u>Drawing Title</u>	
4-001	Curb Ramp Locations	111
4-002	Curb Ramps in Vertical Curb	112
4-003	Curb Ramps in Rolled Curb	113
4-004	Cement Concrete Sidewalk Transition to Asphalt Shoulder	114

SECTION 5-000 ROADSIDE APPURTENANCES

<u>Drawing Number</u>	<u>Drawing Title</u>	
5-001	Clearance of Roadside Obstacles on Shoulder Type Road	115
5-002	Intersection Landing	116
5-003	Barricades	117
5-004	Rock Facing, Cut Section	118

TABLE OF CONTENTS (Continued)

<u>Drawing Number</u>	<u>Drawing Title</u>	
5-005	Rock Facing, Fill Section	119
5-006	Rock Facing Under Sidewalk	120
5-007	Rock Facing, Fill Section Reinforcement	121
5-008	Concrete Steps and Metal Handrail	122
5-009	Street Tree Standards	123
5-010	Mailbox Mounting, Curb Type Location	124
5-011	Mailbox Mounting, Shoulder Type Location	125
5-012	Neighborhood Delivery & Collection Box Unit (N.D.C.B.U.) Mailbox Installation	126
5-013	Bollards	127
5-014	Roadway Survey Monument with Case and Cover	128
5-015	Off-Roadway Survey Monument	129

KING COUNTY ROAD STANDARDS 1993

PURPOSE

King County has adopted these road design criteria primarily for a two-fold purpose:

- (1) To set forth specific, consistent road design elements for developers and other private parties constructing or modifying road or right-of-way facilities which require County licenses or permits;
- (2) To establish uniform criteria to guide the County's own construction of new County roads or reconstruction of existing roads.

In addition, these Standards are intended to support King County's goals for achieving affordable housing, providing adequate facilities for development in an efficient manner, complying with storm water management and sensitive area policies and to balance these goals with the general safety and mobility needs of the traveling public.

In adopting these Road Standards, the County has sought to encourage standardization of road design elements where necessary for consistency and to assure so far as practical that motoring, bicycling, equestrian, and pedestrian public safety needs are met. Considerations include safety, convenience, pleasant appearance, proper drainage, and economical maintenance. The Standards also provide requirements for the location and installation of utilities within the right-of-way. The County's permitting and licensing activities require the adoption of specific, identifiable standards to guide private individuals and entities in the administrative process of procuring the necessary County approval. Yet, the County must have needed flexibility to carry out its general duty to provide streets, roads, and highways for the diverse and changing needs of the traveling public. Accordingly, these Standards are not intended to represent the legal standard by which the County's duty to the traveling public is to be measured.

These Standards cannot provide for all situations. They are intended to assist but not to substitute for competent work by design professionals. It is expected that land surveyors, engineers, and architects will bring to each project the best of skills from their respective disciplines. These Standards are also not intended to limit unreasonably any innovative or creative effort which could result in better quality, better cost savings, or both. Any proposed departure from the Standards will be judged, however, on the likelihood that such variance will produce a compensating or comparable result, in every way adequate for the road user and county resident.

CHAPTER 1. GENERAL CONSIDERATIONS

- 1.01 Shortened Designation: These King County Road Standards will be cited routinely in the text as the "Standards."
- 1.02 Applicability: These Standards shall apply prospectively to all newly constructed road and right-of-way facilities, both public and private, within King County. In the event of conflict with the current short subdivision code, K.C.C. Chapter 19.26, these Standards shall control.

The Standards apply to modifications of roadway features of existing facilities which are within the scope of reconstructions, required off-site road improvements for land developments, or capital improvement projects when so required by King County or to the extent they are expressly referred to in project plans and specifications. These Standards are not intended to apply to "resurfacing, restoration, and rehabilitation" projects as those terms are defined in the Local Agency Guidelines, WSDOT, as amended; however, the Engineer may at his discretion consider the Standards as optional goals.

The Standards shall apply to every new placement and every planned, non-emergency replacement of existing utility poles and other utility structures within the King County right-of-way.

1.03 Responsibility to Provide Roadway Improvements:

- A. Any land development which will impact the service level, safety, or operational efficiency of serving roads or is required by other County code or ordinance to improve such roads shall improve those roads in accordance with these Standards. The extent of off-site improvements to serving roads shall be based on an assessment of the impacts of the proposed land development by the Reviewing Agency.
- B. Any land development abutting and impacting existing roads shall improve the frontage of those roads in accordance with these Standards. The extent of improvements shall be based on an assessment of the impacts of the proposed land development by the Reviewing Agency. Urban residential short plats creating only one additional lot to a tax lot with an existing dwelling unit are exempt from providing urban type street improvements but are subject to shoulder improvements as specified in Section 3.07 provided these improvements are consistent with the surrounding roads.
- C. Any land development that contains internal roads shall construct or improve those roadways to these Standards.
- D. It is the County's practice that it will not allow subdivisions to be recorded unless there exists a recorded continuous public access to the subdivision except as provided for in Section 2.06. Nor will the County accept a road for maintenance until the road is directly connected to a County or other publicly maintained road.

- E. All road improvement and development projects shall include pedestrian access as a part of the design. Where existing roadways are to be modified, pedestrian facilities shall be as described in Sections 3.02, 3.07, 3.08 or 3.09.

1.04 General References: The Standards implement and are intended to be consistent with:

- A. Home Rule Charter for King County, approved by the electorate on November 5, 1968; specifically subsection 920.20.10.
- B. King County Code, as amended, including:
- Title 9, Surface Water Management
 - Title 14, Roads and Bridges
 - Title 16, Building and Construction Standards
 - Title 17, Fire Code
 - Title 19, Subdivisions
 - Title 20, Planning
 - Title 21, Zoning
 - Titles 46 and 47, Traffic
- C. Implementing guidelines on drainage prepared by Surface Water Management Division, King County Department of Public Works, and hereafter referred to as the "Surface Water Design Manual."
- D. King County Comprehensive Plan 1985, as updated.
- E. King County Transportation Plan, current edition.
- F. Affordable Housing Policy Plan.
- G. Adopted Community Plans.
- H. King County Regional Trails Plan.
- I. King County Non-Motorized Transportation Plan.
- J. King County Capital Improvement Program, as amended.
- K. King County Parks and Open Space Plan 1986.
- L. King County Specifications for Off-Street Parking.
- M. King County adopted Basin Control Plans.
- N. King County Flood Hazard Plan, when adopted.

- 1.05 WSDOT/APWA Documents as Primary Design and Construction References: Except where these Standards provide otherwise, design detail, construction workmanship, and materials shall be in accordance with the following publications produced separately by Washington State Department of Transportation (WSDOT), or jointly by WSDOT and Washington State Chapter of American Public Works Association (APWA).
- A. WSDOT/APWA Standard Specifications for Road, Bridge, and Municipal Construction, as adopted by King County, current edition as amended. These will be referred to as the "WSDOT/APWA Standard Specifications."
 - B. The WSDOT/APWA Standard Plans for Road and Bridge Construction, to be referred to as the "WSDOT/APWA Standard Plans," current edition as amended.
 - C. WSDOT Design Manual, current edition as amended.
 - D. City and County Design Standards for the Construction of Urban and Rural Arterial and Collector Roads, adopted per RCW 35.78.039 and RCW 43.32.020, May 24, 1989, current edition as amended.
- 1.06 Other Specifications: The following shall be applicable when pertinent, when specifically cited in the Standards or when required by state or federal funding authority.
- A. Local Agency Guidelines, WSDOT, as amended.
 - B. Guidelines for Urban Arterial Program, WSDOT, as amended.
 - C. Design criteria of federal agencies including the Federal Housing Administration, Department of Housing and Urban Development; and the Federal Highway Administration, Department of Transportation.
 - D. A Policy on Geometric Design of Highways and Streets, American Association of State Highway and Transportation Officials (AASHTO), 1984, or current edition when adopted by WSDOT.
 - E. Standard Specifications for Highway Bridges, adopted by AASHTO, current edition.
 - F. U. S. Department of Transportation Manual on Uniform Traffic Control Devices, "MUTCD", as amended and approved by Washington State Department of Transportation, current edition.
 - G. Guide for the Development of Bicycle Facilities, adopted by AASHTO, current edition.
 - H. Associated Rockery Contractors, Standard Rock Wall Construction Guidelines.
 - I. American Society for Testing and Materials (ASTM).
- 1.07 Road Plans: Plans for roads and road drainage shall be prepared and submitted consistent with these Standards and in accordance with administrative rule published by the Director, Department of Public Works. These requirements shall apply to public or private roads whether constructed by private party or

public agency. Subject to review, the Reviewing Agency may waive plan requirements, wholly or in part, based on the following criteria:

- A. For improvements to existing roads if:
1. No more than 5,000 square feet will be cleared and graded within the right-of-way or easement; and
 2. The existing grade or slope in the road right-of-way or easement does not exceed 12 percent; and
 3. The work will not intercept a stream or wetland or otherwise impact natural surface drainage as set forth in County Code regarding Sensitive Areas and the Surface Water Design Manual; and
 4. Plans do not include a retention/detention facility within the right-of-way; and
 5. The work is required of a short plat development, or a right-of-way use permit and involves less than 100 lineal feet of existing public road improvement; and
 6. King County standard drawings, submitted with required permits, are sufficient to describe the improvement to be constructed.

1.08 Variances

- A. Variances from these Standards may be granted by the Engineer upon evidence that such variances are in the public interest and that requirements for safety, function, fire protection, appearance and maintainability based upon sound engineering judgement are fully met. Detailed procedures for requesting variances and appealing variance decisions are contained in an administrative rule available from the County Road Engineer. Variance requests for subdivisions should be proposed at preliminary plat stage and prior to any public hearing. Variances must be approved prior to approval of the engineering plans for construction. Any anticipated variances from these Standards which do not meet the Uniform Fire Code shall also require concurrence by the King County Fire Marshal.
- B. Questions regarding interpretation of these Standards may be directed to the Reviewing Agency, Site Development Coordinator, at 296-6640 or the Roads and Engineering Services Variance Engineer at 296-3783.

1.09 Penalties and Financial Guarantees: Failure to comply with these Standards may result in denial of plan or development permit approval, revocation of prior approvals, legal action for forfeiture of financial guarantee, code enforcement, and/or other penalties as provided by law.

A. CONSTRUCTION PERFORMANCE GUARANTEES: Any construction work on King County right-of-way (both maintained and unmaintained) other than Capital Improvement Projects or County maintenance work shall be guaranteed by a financial guarantee. All work on private road and drainage facilities required as a condition of a County approval process shall be guaranteed by a financial guarantee at the time of plat recording. The amount and form of the financial guarantee shall be determined by the Reviewing Agency. The minimum performance guarantee shall be \$1,000.00

The amount of the financial guarantee may be reduced during construction, as determined by the Reviewing Agency. At no time will the financial guarantee amount be reduced to less than 30 percent of the original amount or \$1,000.00, whichever is greater.

B. MAINTENANCE PERFORMANCE GUARANTEES: The successful performance of the right-of-way improvements shall be guaranteed for a period of at least one year (or other period if updated by King County Code) from the latest date of either the acceptance or Final Construction Approval. The amount and form of the maintenance financial guarantee shall be determined by the Reviewing Agency. The minimum maintenance guarantee shall be \$1,000.00. Maintenance guarantees will not be required when the required performance guarantee is \$1,000.00.

1.10 Meaning of Terms

"Alley": A thoroughfare or right-of-way, usually narrower than a street, which provides access to the rear boundary of two or more residential properties and is not intended for general traffic circulation; privately maintained.

"Auxiliary Lane": The portion of the roadway adjoining the traveled way for parking, turning or other purposes supplementary to through-traffic movement.

"Bulb": Round area for vehicle turnaround typically located at the end of a cul-de-sac street.

"Cul-de-sac": Short street having one end open to traffic and the other temporarily or permanently terminated by a vehicle turnaround.

"Design Speed": The speed approved by the Reviewing Agency or the Engineer for the design of the physical features of a road as established by Sections 2.03 and 2.04 for residential and commercial access streets or equal to 10 miles per hour above the current or expected posted speed limit for arterials.

"Developer": Any person, firm, partnership, association, joint venture or corporation or any other entity who undertakes to improve residential, commercial, or industrial property or to subdivide for the purpose of resale and profit.

"Driveway": A privately maintained access to residential, commercial or industrial properties.

"Engineer": King County Road Engineer, having authorities specified in RCW 36.75.050 and 36.80, or his/her authorized representative.

"Eyebrow": A partial bulb located adjacent to the serving road that provides access to lots and serves as a vehicle turnaround.

"Half-Street": Street constructed along edge of development, utilizing a portion of the regular width of right-of-way and permitted as an interim facility pending construction of the other half of the street by the adjacent owner.

"Joint-Use Driveway Tract": A jointly owned and maintained tract or easement serving two properties.

"Landing": A road or driveway approach area to any public or private road.

"Loop": Road of limited length forming a loop, having no other intersecting road, and functioning mainly as direct access to abutting properties. A loop may be designated for one-way or two-way traffic.

"Off-Street Parking Space": An area accessible to vehicles, exclusive of roadways, sidewalks, and other pedestrian facilities, that is improved, maintained and used for the purpose of parking a motor vehicle.

"Pavement Width": Paved area on shoulder-type roads or paved surface between curb, thickened edge or gutter flow line on all other roads as depicted on Drawings 1-001 through 1-003, 1-005 and 1-006.

"Pipe Stem": A strip of land having a width narrower than that of the lot or parcel to be served and is designed for providing access to that lot or parcel.

"Private Access Tract": A privately owned and maintained tract providing vehicular access to six or fewer residential properties.

"Private Street": A privately owned and maintained access provided for by a tract, easement or other legal means, typically serving three or more potential dwelling units.

"Professional Engineer": A professional civil engineer licensed to practice in the State of Washington.

"Public Street": Publicly owned facility providing access, including the roadway and all other improvements, inside the right-of-way.

"Reviewing Agency": King County Department of Development and Environmental Services or its successor agency for plats and proposed developments.

"Right-of-Way": Land, property, or property interest (e.g., an easement), usually in a strip, acquired for or devoted to transportation purposes.

"Road": A facility providing public or private access including the roadway and all other improvements inside the right-of-way.

"Road" and "Street" will be considered interchangeable terms for the purpose of these Standards.

"Roadway": Pavement width plus any non-paved shoulders.

"Resource Lands": Areas so designated in King County Comprehensive Plan and as implemented through community plans and area zoning; characterized by long-term agriculture, forestry, and mining.

"Rural Areas": Areas so designated in King County Comprehensive Plan, and as implemented through community plans and area zoning; characterized by long-term low density of development.

"Shoulder": The paved or unpaved portion of the roadway outside the traveled way that is available for emergency parking or non-motorized use.

"Traffic Engineer": King County Traffic Engineer responsible for design, operation and maintenance of traffic control devices.

"Transitional Areas": Areas so designated in the King County Comprehensive Plan; characterized by low density but earmarked for redesignation through a community plan as either a rural or an urban area.

"Traveled Way": The part of the road made for vehicle travel excluding shoulders and auxiliary lanes.

"Urban Areas": Areas so designated in King County Comprehensive Plan, and as implemented through community plans and area zoning; characterized by denser commercial/industrial and residential development.

"Utility": A company providing public service such as gas, electric power, telephone, telegraph, water, sewer, or cable television, whether or not such company is privately owned or owned by a governmental entity.

- 1.11 Severability: If any part of these King County Road Standards as established by ordinance shall be found invalid, all other parts shall remain in effect.

CHAPTER 2. ROAD TYPES & GEOMETRICS

2.01 Road Classifications

- A. County roads are classified functionally as indicated in Sections 2.02, 2.03, and 2.04. Function is the controlling element for classification and shall govern right-of-way, road width and road geometrics. Other given elements such as access, arterial spacing and average daily traffic count (ADT) are typical.
- B. Within each functional classification, roads are further characterized as "curb" or "shoulder" type. A "curb" type road typically requires curb and gutter with inlets and underground pipe drainage. A "shoulder" type road typically requires a shoulder and open ditch drainage.
 - 1. Land developments in urban areas, as defined by the current King County Comprehensive Plan Map, shall provide "curb" type road improvements. Exceptions to this may be approved by the Reviewing Agency on residential access streets which are located in long-term, low density neighborhoods as designated by adopted community plans and where a pattern of "shoulder" type roads is firmly established. Exceptions for two-lot urban short plats are as allowed in Section 1.03.
 - 2. Land developments in rural areas as defined by the current King County Comprehensive Plan Map shall provide "shoulder" type road improvements unless otherwise approved by the Reviewing Agency. Certain exceptions to the "shoulder" type standard may apply within clustered housing developments and rural activity centers (unincorporated rural towns such as Vashon or Fall City) where urban densities and uses may make a "curb" type road appropriate. Within these developments, the specifically authorized land uses, adopted community plans or business district design guidelines may provide for either a "curb" or "shoulder" type road section.
 - 3. Land developments in transitional areas as defined by the current King County Comprehensive Plan Map shall provide "curb" or "shoulder" type road improvements as specified by the Reviewing Agency.
 - 4. Guidelines applicable to Rural Areas shall apply also to Resource Lands.

2.02 Arterial Roads¹ Comprising the County primary road system, see Drawings No. 1-001 and 1-002.

CLASSIFICATION	PRINCIPAL ARTERIALS		MINOR ARTERIALS		COLLECTOR ARTERIALS OR "COLLECTORS"				
FUNCTION	Inter-community highways connecting largest community centers & facilities		Intra-community highways connecting community centers and facilities.		Intra-community highways connecting residential neighborhoods with community centers & facilities.				
Access	Controlled with very restricted access to abutting properties.		Partially controlled with infrequent access to abutting properties.		Partially controlled with infrequent access to abutting properties.				
Land Use Area	Rural	Urban	Rural	Urban	Rural			Urban	
Arterial Spacing	2 to 5 Miles	2 to 5 Miles	Under 2 Miles	Under 2 Miles	Under 2 Miles			Under 2 Miles	
ADT	Over 2000	Over 2000	Over 2000	Over 2000	Over 2000	400 to 2000	Under 400		
CRITERIA									
A. Typical Road Type	Shoulder	Curb	Shoulder	Curb	Shoulder [8]	Shoulder [8]	Shoulder [8]	Curb [9]	
B. Design Speed [2] (MPH)	Varies 40 - 60	Varies 40 - 60	Varies 35 - 55	Varies 35 - 55	Varies 40 - 50	Varies 35 - 50	Varies 35 - 50	Varies 35 - 50	
C. Standard Superelevation (Ft. / Ft.) [9]	0.06	0.06	0.06	0.06	0.06	0.06	0.06	0.06	
D. Horizontal Curvature	See Table 2.1	See Table 2.1	See Table 2.1	See Table 2.1	See Table 2.1	See Table 2.1	See Table 2.1	See Table 2.1	
E. Maximum Grade (%) [3]	9	9	10	10	10	10	10	12	
F. Standard Stopping Sight Distance (Ft.) [4]	See Table 2.1	See Table 2.1	See Table 2.1	See Table 2.1	See Table 2.1	See Table 2.1	See Table 2.1	See Table 2.1	
G. Standard Entering Sight Distance (Ft.) [5]	See Table 2.1	See Table 2.1	See Table 2.1	See Table 2.1	See Table 2.1	See Table 2.1	See Table 2.1	See Table 2.1	
H. Minimum Passing Sight Distance on 2-Lane Road. (Ft.)	See Table 2.1	See Table 2.1	See Table 2.1	See Table 2.1	See Table 2.1	See Table 2.1	See Table 2.1	See Table 2.1	
I. Minimum Traveled Way (Ft.) [6]	2/3-Lane	22/34	44	22/34	44	22/34	22	22	36
	4-Lane	44	44	44	44	44	-	-	44
	5-Lane	56	56	56	56	-	-	-	-
J. Minimum Roadway Width (Ft.) [6]	2/3-Lane	38/50	44	38/50	44	38 [8]/50 [8]	34 [8]	30 [8]	44 [7]
	4-Lane	60	54 [7]	60	54 [7]	60 [8]	-	-	54 [7]
	5-Lane	72	66 [7]	72	66 [7]	-	-	-	-
K. Min. Right-of-Way Width (Ft.)	2/3-Lane	100	100	84	84	60	60	60	60
	4-Lane	100	100	-	84	84	-	-	-
	5-Lane	100	100	100	84	-	-	-	84
L. Type of Curb or Shoulder & Ditch [6]	8' Shoulder & Ditch	Vertical Curb & Gutter	8' Shoulder & Ditch	Vertical Curb & Gutter	8' Shoulder & Ditch [8]	6' Shoulder & Ditch [8]	4' Shoulder & Ditch [8]	Vertical Curb & Gutter	

M.

NOTES:

- 1 - Within the above parameters, geometric design requirements shall be determined for specific arterial roads consistent with the WSDOT Design Manual.
- 2 - Design speed is a basis for determining geometric elements and does not imply posted or legally permissible speed. Curves shall be designed within parameters of B, C, and D above. (See Section 2.05.)
- 3 - Maximum grade may be exceeded for short distances. (See Section 2.11.)
- 4 - Standard Stopping Sight Distance (SSD) shall apply unless otherwise approved by the Engineer. (See Section 2.12.)
- 5 - Standard Entering Sight Distance (ESD) shall apply at intersections and driveways unless otherwise approved by the Engineer. (See Section 2.13.)
- 6 - Criteria for state and federal funding may require greater width. For guardrail installations, shoulders shall be two feet wider.
- 7 - Pavement width may be reduced on Urban Arterials where bikeways are not required by the Non-Motorized Plan.
- 8 - Rural collectors may, as alternative, have vertical curb and gutter at minimum width of 36 feet curb to curb.
- 9 - See Section 2.05 for allowed uses of superelevations greater than 6 percent.

2.03 Residential Access Streets¹ Serving single-family development, see Drawings No. 1-001 through 1-006.
For multiple-dwelling development, see Section 2.04.

		LOCAL ACCESS STREETS							
CLASSIFICATION	NEIGHBORHOOD COLLECTORS	SUBCOLLECTORS		SUBACCESS STREETS		MINOR ACCESS STREETS (RESIDENTIAL)			
FUNCTION	Streets connecting two or more neighborhoods and typically connecting to arterials or other neighborhood collectors.	Streets providing circulation within neighborhoods typically connecting to neighborhood collectors.		Permanent cul-de-sacs, or short loops [2], connecting to subcollectors and not supportive of through traffic.		Permanent cul-de-sacs or loops [2], with low traffic, providing circulation and access to off-street parking within residential development boundaries.			
Public or Private	Public streets	Public streets		Typically public streets For private streets (See Sec. 2.06.)		Public or private streets. (See Sec. 2.06.)			
Access	Restricted, Lots front on Local Access street where feasible.	As needed with some restrictions.		As needed with only minimal restrictions.		As needed with only minimal restrictions.			
Land Use Area	Rural	Urban	Rural	Urban	Rural	Urban	Rural	Urban	
Serving Potential Number of Single-Family Dwelling Units	Over 100 [3]	Over 100 [3]	100 Max.	100 Max. [4]	50 Max.	50 Max.	16 Max.	16 Max.	
CRITERIA									
A. Typical Road Type	Shoulder	Curb	Shoulder	Curb	Shoulder	Curb	Shoulder	Curb	
B. Design Speed [5] (MPH)	35	35	30	30	Low Speed Curve See Sec. 2.10	Low Speed Curve See Sec. 2.10	Low Speed Curve See Sec. 2.10	Low Speed Curve See Sec. 2.10	
C. Max. Superelevation (Ft./Ft.)	0.06	See Sec. 2.05B	0.06	See Sec. 2.05B	See Sec. 2.05B	See Sec. 2.05B	See Sec. 2.05B	See Sec. 2.05B	
D. Horizontal Curvature Min. Radius (Ft.)	See Table 2.1	See Table 2.2	See Table 2.1	See Table 2.2	Low Speed Curve See Sec. 2.10	Low Speed Curve See Sec. 2.10	Low Speed Curve See Sec. 2.10	Low Speed Curve See Sec. 2.10	
E. Max. Grade [6]	11	12	12	15	15	15	15	15	
F. Standard Stopping Sight Distance (Ft.) [7]	See Table 2.1	See Table 2.2	See Table 2.1	See Table 2.2	150 ft.	150 ft.	150 ft.	150 ft.	
G. Standard Entering Sight Distance (Ft.) [8]	See Table 2.1	See Table 2.2	-	-	-	-	-	-	
H. Min. Pavement Width (Ft.)	22	32[9]	22	28	20	24	20[10]	22	
I. Min. Roadway Width (Ft.) [11]	38	32[9]	38	28	28	24	28 [10]	22	
J. Min. Right-of-Way Width (Ft.)	60	56	60	48[12]	48 [12]	40[12]	48 [12]	40[12]	
K. Type of Curb or Shoulder and Ditch [11]	8' Shoulder & Ditch [13]	Vertical Curb & Gutter	8' Shoulder & Ditch [13]	Vertical or Rolled Curb & Gutter	4' Shoulder & Ditch [13]	Vertical or Rolled Curb & Gutter	4' Shoulder & Ditch [13]	Vertical or Rolled Curb & Gutter	
L. Min. Half St. Paved Width (Ft.)	20	20	20	20	20	20	20	20	
M. Min. One-Way Paved Width (Ft.)	20	20	20	20	20	20	20	20	

N. NOTES:

- 1 - Within the above parameters, geometric design for specific streets shall be consistent with AASHTO Policy on Geometric Design of Highways and Streets.
- 2 - See Section 2.15 for one-way loops.
- 3 - See Section 2.20 for residential access connection requirements.
- 4 - See Section 2.21 for urban exception criteria.
- 5 - Design speed is a basis for determining geometric elements and does not imply posted or legally permissible speed. Curves shall be designed within parameters of B, C and D above. (See Section 2.05)
- 6 - Maximum grade may be exceeded for short distances. (See Section 2.11)
- 7 - Standard Stopping Sight Distance (SSD) shall apply unless otherwise approved by the Engineer. (See Section 2.12)
- 8 - Standard Entering Sight Distance (ESD) shall apply at intersections and driveways on neighborhood collectors unless otherwise approved by the Engineer (See Section 2.13)
- 9 - Neighborhood collectors intersecting with arterials shall be 36 feet wide for the first 150 feet. See Section 4.05 for tapers.
- 10 - Exception to paving requirement on minor access shoulder type streets: (See Section 2.17)
- 11 - For guardrail installation, shoulders shall be two feet wider.
- 12 - Right-of-way (easement) may be reduced to minimum roadway width, plus sidewalks, provided that all potential serving utilities and necessary drainage are otherwise accommodated on permanent easements within the development. (See Section 2.19)
- 13 - As alternative to shoulder and ditch, underground pipe drainage with either Thickened Edge, Dwg. 1-005 or Extruded Curb, Dwg. 1-006 is acceptable.

2.04 Commercial Access Streets¹ (See Drawings No. 1-001 and 1-002.)

CLASSIFICATION	MULTIPLE-DWELLING ACCESS STREETS		BUSINESS ACCESS STREETS		INDUSTRIAL ACCESS STREETS		MINOR ACCESS STREETS (COMMERCIAL)	
FUNCTION	Local streets abutting two-family and multiple-dwelling development.		Local streets abutting dense multiple-dwelling and services, office, professional activities.		Local streets abutting manufacturing, processing, storing & handling activities.		Local streets providing circulation and access to parking and loading sites within multi-dwelling, business, and industrial development boundaries.	
Public or Private Streets	Typically public streets serving all RD and RM zones except RM 900.		Typically public streets serving RM 900 and all B (business) zones.		Typically public streets serving CG and all M Zones.		Public or private streets. (See Section 2.06.)	
Access	As needed, with some regulation.		As needed, with some regulation.		As needed, with some regulation.		As needed with only minimal restrictions.	
Land Use Area	Rural	Urban	Rural	Urban	Rural	Urban	Rural	Urban
CRITERIA								
A. Typical Road Type	Shoulder	Curb	Shoulder	Curb	Shoulder	Curb	Shoulder	Curb
B. Design Speed [2] (MPH)	35	35	35	35	35	35	Low Speed See Sec. 2.10	Low Speed See Sec. 2.10
C. Max. Superelevation (Ft./Ft.)	0.06	0.06	0.06	0.06	0.06	0.06		
D. Horizontal Curvature Min. Radius (Ft.) [2]	See Table 2.1	See Table 2.1	See Table 2.1	See Table 2.1	See Table 2.1	See Table 2.1	Low Speed Curve See Sec. 2.10	Low Speed Curve See Sec. 2.10
E. Maximum Grade (%) [3]	12	12	12	12	11	11	12	12
F. Standard Stopping Sight Distance (Ft.) [4]	See Table 2.1	See Table 2.1	See Table 2.1	See Table 2.1	See Table 2.1	See Table 2.1	150	150
G. Standard Entering Sight Distance (Ft.) [5]	See Table 2.1	See Table 2.1	See Table 2.1	See Table 2.1	See Table 2.1	See Table 2.1	N/A	N/A
H. Min. Pavement Width (Ft.)	22	36	24	36	24	40	20	24
I. Min. Roadway Width (Ft.) [6]	38	36	40	36	40	40	28 [7]	24 [7]
J. Min. Right-of Way Width (Ft.)	60	56	60	56	60	60	48 [7]	40 [7]
K. Type of Curb or Shoulder & Ditch [6]	8' Shoulder & Ditch	Vertical Curb & Gutter	8' Shoulder & Ditch	Vertical Curb & Gutter	8' Shoulder & Ditch	Vertical Curb & Gutter	4' Shoulder & Ditch	Vertical Curb & Gutter
L. Min. Half Street Paved Width (Ft.)	20	20	20	20	20	20	20	20
M. Min. One-Way Paved Width (Ft.)	20	20	22	22	24	24	20	20

N. NOTES:

- 1 - "Commercial Access Streets" serve multiple-dwelling, business, and industrial developments. Within the above parameters, geometric design requirements shall be determined for specific streets consistent with the WSDOT Design Manual.
- 2 - Design speed is a basis for determining geometric elements and does not imply posted or legally permissible speed. Curves shall be designed within parameters of B, C, and D above. (See Section 2.05.)
- 3 - Maximum grade may be exceeded for short distances. (See Section 2.11.)
- 4 - Standard Stopping Sight Distance (SSD) shall apply unless otherwise approved by the Engineer. (See Section 2.12.)
- 5 - Standard Entering Sight Distance (ESD) shall apply at intersections and driveways except on minor access streets unless otherwise approved by the Engineer. (See Section 2.13.)
- 6 - For guardrail installations, shoulders shall be two feet wider.
- 7 - Right-of-way (or easement) may be reduced to minimum roadway width, plus sidewalk, provided that potential serving utilities and necessary drainage are otherwise accommodated within permanent easements through the development. (See Section 2.19.)

2.05 Horizontal Curvature and Sight Distance Design Values

- A. The design values shown in Tables 2.1 and 2.2 are minimum values necessary to meet the requirements of Sections 2.02, 2.03 and 2.04 for a selected design speed and road classification. A maximum of 8 percent superelevation may be used, upon approval of the Engineer, for design of improvements to existing arterials, as necessary, to meet terrain and right-of-way conditions. Superelevation run-off lengths on arterials, rural residential and commercial access streets shall be calculated in accordance with the WSDOT Design Manual.
- B. Superelevation is not required in the design of horizontal curves on urban residential access streets; however, horizontal curves must be designed based on design speed and selected cross section as indicated in Table 2.2. Table 2.2 is based on AASHTO "Low Speed Urban Streets" design methodology. Superelevation may be used on urban residential streets as necessary to meet terrain and right-of-way conditions.

Table 2.1

Arterial Roads, Rural Residential And Commercial Access Streets
Design Values

Design Speed (mph)	30	35	40	45	50	55	60
Horizontal Curvature for 6 percent Superelevation, Radius (Ft.)	273	380	509	656	849	1,061	1,348
Horizontal Curvature for 8 percent (maximum allowable on arterials) Superelevation, Radius (Ft.) (requires approval of the Engineer)	250	350	465	600	760	960	1,200
Stopping Sight Distance (Ft.)	200	250	325	400	475	550	650
Entering Sight Distance (Ft.)	430	490	555	620	685	750	810
Passing Sight Distance (Ft.) for a 2-Lane Road	1,100	1,300	1,500	1,650	1,800	1,950	2,100

Table 2.2

Urban Residential Access Streets Design Values

Design Speed (mph)	25	30	35
Horizontal Curvature, for 6 Percent Superelevation, Radius (Ft.)	135	215	320
Horizontal Curvature, for 4 Percent Superelevation, Radius (Ft.)	145	230	345
Horizontal Curvature, for 2 Percent Superelevation, Radius (Ft.)	155	250	375
Horizontal Curvature, Normal Crown Section, Radius (Ft.)	180	300	460
Stopping Sight Distance (Ft.)	150	200	250
Entering Sight Distance (Ft.)	365	430	490
Minimum Run-Off Length (Ft.)	80	90	100

2.06 Private Streets

- A. While community street requirements are usually best served by public streets, owned and maintained by the County, private streets may be appropriate for some local access streets. Usually these are minor access streets, either residential or commercial.
- B. Private streets may be approved only when they are:
 - 1. Permanently established by right-of-way, tract or easement providing legal access to each affected lot, dwelling unit, or business and sufficient to accommodate required improvements, to include provision for future use by adjacent property owners when applicable; and
 - 2. Built to King County Road Standards, as set forth herein, or secured under the provisions of K.C.C. 19.24.040; and
 - 3. Accessible at all times for emergency and public service vehicle use; and
 - 4. Not obstructing, or part of, the present or future public neighborhood circulation plan developed in processes such as the King County Comprehensive Plan, applicable community plan, or Capital Improvement Program; and
 - 5. Not going to result in land locking of present or future parcels; and
 - 6. Not needed as public roads to meet the minimum road spacing requirements of these Standards; and

7. Designed to serve a maximum potential of 16 single-family dwelling units when the entire length of the private road system to the nearest public road is considered. The maximum potential is the number of dwelling units that can possibly be served by the road when physical barriers, zoning or other legal constraints are considered; and
 8. Maintained by a capable and legally responsible owner or homeowners' association or other legal entity made up of all benefited property owners, under the provisions of K.C.C. 19.24.050; and
 9. Clearly described on the face of the plat, short plat, or other development authorization and clearly signed at street location as a private street, for the maintenance of which King County is not responsible.
- C. King County will not accept private streets for maintenance as public streets until such streets are brought into conformance with current County road standards. This requirement will include the hard surface paving of any streets originally surfaced with gravel.
 - D. King County will not accept private streets within short plats when the roads providing access to the plat are private and already have the potential to serve more than the number of lots specified in Section 2.06 B.7. Short plats proposed on properties to which the access is over private streets that do not meet the standards in this section shall be denied.

2.07 Half Streets. See Drawing No. 1-010

- A. A half street may be permitted as an interim facility when:
 1. Such street shall not serve as primary access to more than 35 dwelling units or tax lots; and
 2. Such alignment is consistent with or will establish a reasonable circulation pattern; and
 3. There is reasonable assurance of obtaining the prescribed additional right-of-way from the adjoining property with topography suitable for completion of a full-section road.
- B. A half street shall meet the following requirements:
 1. Right-of-way width of the half street shall equal at least 30 feet; and
 2. If feasible, half street shall be graded consistent with locating centerline of the ultimate road section on the property line; and
 3. Traveled way shall be surfaced the same as the designated road type to a width not less than 20 feet, sidewalk shall be constructed as required for the designated road type; and

4. Property line edge of street shall be finished with temporary curbing, shoulders, ditches, and/or side slopes so as to assure proper drainage, bank stability, and traffic safety; and
 5. Half streets shall not intersect other half streets unless so approved by the Engineer.
- C. When a half street is eventually completed to a whole street, the completing builder shall reconstruct the original half street as necessary to produce a proper full-width street of designated section.
- D. The obtaining of any right-of-way or easements needed to accomplish the above shall be the responsibility of the owning builder or developer.

2.08 Cul-de-sacs and Eyebrows. See Drawing No. 1-007.

- A. Whenever a cul-de-sac street serves more than six lots or extends more than 150 feet from centerline of accessing street to farthest extent of surfaced traveled way a widened "bulb" shall be constructed as follows:
1. Minimum right-of-way diameter across bulb section: 100 feet in a permanent cul-de-sac; 84 feet in a temporary cul-de-sac, with bulb area lying outside straight-street right-of-way provided as temporary easement pending forward extension of the street. Right-of-way may be reduced, provided utilities and necessary drainage are accommodated on permanent easements within the development. See Section 2.19.
 2. Minimum diameter of surfacing across bulb: 80 feet of paving in curb type road; 80 feet total in shoulder type road to include 64 feet of paving and eight-foot shoulders with compacted crushed surfacing material.
 3. Cul-de-sac Island: Optional feature for any cul-de-sac when bulb paved diameter is 80 feet or less; mandatory when bulb paved diameter exceeds 80 feet. If provided, island shall have full-depth vertical curb. Minimum diameter shall be 20 feet and there shall be at least 22 feet of paved traveled way in a shoulder type section; 30 feet of paved traveled way in a curb type section around the circumference. Island shall be grassed or landscaped. It shall be maintained by the adjoining lot owners.
 4. Where required on cul-de-sacs, sidewalks shall be constructed on one side and on the bulb, terminating on a property line at or near half-way around the bulb.
- B. A permanent cul-de-sac shall not be longer than 600 feet measured from centerline of intersecting street to the center of the bulb section. Proposed exceptions to this rule will be considered by the Engineer based on pertinent traffic planning factors such as topography, sensitive areas and existing development. The cul-de-sac length may extend to 1,000 feet if 50 or fewer potential lots are to be served and there is provision for emergency turnaround near mid-length.

- C. The Engineer or Reviewing Agency may require an off-street walk or an emergency vehicle access to connect a cul-de-sac at its terminus with other streets, parks, schools, bus stops, or other pedestrian traffic generators, if the need exists.
- D. If a street temporarily terminated at a property boundary serves more than six lots or is longer than 150 feet, a temporary bulb shall be constructed near the plat boundary. The paved bulb shall be 80 feet in diameter with sidewalks terminated at the point where the bulb radius begins. Removal of the temporary cul-de-sac and extension of the sidewalk shall be the responsibility of the developer who extends the road. See Drawing No. 1-008.
- E. The maximum cross slope in a bulb shall not exceed 6 percent.
- F. Partial bulbs or eyebrows shall have a minimum paved radius and an island configuration as shown on Drawing No. 1-009. Island shall be offset two feet from edge of traveled way.

2.09 Alleys and Private Access Tracts

- A. An alley is considered a private road. Requirements of Section 2.03, subaccess streets, for horizontal curvature and stopping sight distance, apply.
 - 1. Serves a maximum of 30 lots, with a maximum length of 400 feet, no dead ends or cul-de-sacs.
 - 2. Minimum tract width 20 feet with a pavement surface of 18 feet (including thickened edge), based on a five-foot structure setback. For differing structure setback requirements, alley configuration shall be designated to provide for safe turning access to properties.
 - 3. Paved surface shall have a thickened edge on one side and cross slope in one direction. See Drawing No. 1-011.
 - 4. Public streets to which an alley connects or which provide access to the front boundary of the properties served by the alley shall be 28-foot minimum paved width with vertical curb. Alley entry shall be provided by a driveway cut.
 - 5. Modifications to existing alleys serving commercial or industrial properties, in accordance with the above, will be determined on a case-by-case basis subject to approval by the Reviewing Agency.
- B. Private access tracts shall conform to Section 2.03 for urban minor access roads and Section 2.06.
 - 1. Serves a maximum of six parcels.
 - 2. Minimum tract width of 26 feet with a maximum length of 150 feet, measured from centerline of intersecting street to furthest extent of paved tract.

3. Pavement width shall be a minimum of 22 feet.

2.10 Intersections and Low Speed Curves

A. Intersections

- | | |
|--|--|
| 1. Angle of intersection (measured at 10 feet beyond road classification right-of-way) | Minimum 85 degrees
Maximum 95 degrees |
| 2. Minimum centerline radius (2-lane) | 55 Feet |
| 3. Minimum curb radius | |
| a. Urban streets and roads classified neighborhood collector or higher | 35 Feet |
| b. Rural streets and roads | 35 Feet |
| c. Urban residential access street intersections where the highest classification involved is subcollector | 25 Feet |
| 4. Minimum right-of-way line radius | 25 Feet |

B. Spacing between adjacent intersecting streets, whether crossing or T-connecting, shall be as follows:

When highest classification involved is:	Minimum centerline offset shall be:
Principal arterial	1,000 Feet
Minor arterial	500 Feet
Collector arterial	300 Feet
Neighborhood collector	150 Feet
Any lesser street classification	100 Feet

- C. On sloping approaches at an intersection, landings shall be provided with grade not to exceed one foot difference in elevation for a distance of 30 feet approaching an arterial or 20 feet approaching a residential or commercial street, measured from future right-of-way line (extended) of intersecting street as provided in Section 2.02, 2.03 or 2.04. See Drawing No. 5-002.
- D. Entering Sight Distance. See Sections 2.02, 2.03, 2.04 and 2.12 for design requirements. See Tables 2.1 or 2.2 for specific entering sight distance values based on required design speed.

E. Low Speed Curves, applicable to subaccess and minor access streets only. See Sections 2.03 and 2.04.

	<u>Up to 75°</u>	<u>75° & Over</u>
1. Minimum centerline radius (2-lane)	100 feet	55 feet
2. Minimum curb radius	80 feet	35 feet
3. Minimum right-of-way line radius	70 feet	25 feet

2.11 Maximum Grade and Grade Transitions

- A. Maximum grade as shown in Sections 2.02, 2.03, and 2.04 may be exceeded for short distances of 300 feet or less, upon showing that no practical alternative exists. Exceptions which exceed 15% will require verification by the Fire Marshal that additional fire protection requirements will be met. Grades exceeding 12 percent shall be paved with asphalt concrete (AC) or portland cement concrete (PCC). Any grade over 20 percent must be PCC.
- B. Grade transitions shall be constructed as smooth vertical curves except in intersections where the difference in grade is one percent or less and upon approval of the Engineer or Reviewing Agency.

2.12 Stopping Sight Distance (SSD) applies to street classifications as shown in Sections 2.02, 2.03 and 2.04. See Tables 2.1 and 2.2 for specific SSD values based on required design speed.

- A. Height of eye is 3.5' and height of object is 0.5'.
- B. Minimum SSD for any downgrade averaging three percent or steeper as provided in Section 2.05, Tables 2.1 and 2.2 shall be increased by the values shown below for any downgrade averaging three percent or steeper (Source: AASHTO Policy on Geometric Design, Table III-2). Interpolate values for other design speeds and grades.

SSD ADJUSTMENT VALUES (FT)

<u>DESIGN SPEED (MPH)</u>	<u>DOWNGRADE</u>	<u>3 Percent</u>	<u>6 Percent</u>	<u>9 Percent</u>
60		50	110	
50		30	70	
40		20	40	70
30		10	20	30
20		0	10	20

- C. Sag vertical curves on subaccess and minor access streets with stopping sight distance less than that called for in Section 2.03 may be approved by the Reviewing Agency if no practical design exists and if acceptable road lighting is provided throughout the curve and is maintained by a franchised utility.

D. Intersecting Stopping Sight Distance.

1. Stopping sight distances for the design speeds of proposed commercial access streets, neighborhood collector streets and arterials must be met when intersecting arterials.
2. The minimum stopping sight distance on proposed intersection approaches for all other classifications of intersecting roadways shall be 125 feet.

2.13 Entering Sight Distance (ESD)

Entering sight distance applies on driveways and on streets approaching intersections as set forth in Sections 2.02, 2.03, and 2.04. Entering sight distance criteria will not apply on local access streets or minor access streets (commercial). Specific ESD values for required design speeds are listed in Section 2.05, Tables 2.1 and 2.2.

- A. Entering vehicle eye height is 3.5 feet, measured from 10-foot back from edge of traveled way. Approaching vehicle height is 4.25 feet.
- B. Requirements in Section 2.05, Tables 2.1 and 2.2 apply to an intersection or driveway approach to a typical road under average conditions. In difficult topography the Engineer may authorize a reduction in the ESD based on factors mitigating the hazard. Such factors may include an anticipated posted or average running speed less than the design speed or the provision of acceleration lanes and/or a median space allowing an intermediate stop by an approaching vehicle making a left turn.
- C. Where a significant number of trucks will be using the approach road, the Engineer may increase the entering sight distance requirements by up to 30 percent for single-unit trucks and 70 percent for semi-trailer combinations.

2.14 Medians (Optional Design Feature)

Median width shall be additional to, not part of, the specified width of traveled way. Edges shall be similar to outer road edges: either extruded or formed vertical curb; or shoulder and ditch; except that median shoulders shall be minimum four feet in width. Twenty feet of driveable surface (which includes traveled way and paved shoulders, if any) shall be provided on either side of the median. Median may be grassed, landscaped, or surfaced with aggregate or pavement. Median shall be designed so as not to limit turning radii or sight distance at intersections. No portion of a side street median may extend into the right-of-way for an arterial street. The Engineer may require revisions to medians as necessary to provide for new access points and to maintain required sight distance. Non-yielding or non-breakaway structures shall not be installed in medians. Street trees may be planted in median subject to approval by the Engineer.

2.15 One-Way Streets

Local access streets, including loops, may be designated one-way upon a finding by the Engineer that topography or other site features make two-way traffic impractical.

2.16 Bus Zones and Turn-Outs

During the design of arterials and neighborhood collectors, the designer shall contact Metro Service Planning, phone 684-1622 and the local school district to determine bus zone (stop) locations and other bus operation needs. The road project shall provide wheel chair accessible landing pads at designated bus zones as per Section 3.02 of the Standards and where required shall include turn-outs and shelter pads. Pedestrian and handicapped access improvements within the right-of-way to and from the bus loading zone or turn-out from nearby businesses or residences shall also be provided as part of the road improvement. Surfacing requirements may also be affected, particularly on shoulders. See Section 4.01B of the Standards. Metro's publication, "Metro Transportation Facility Design Guidelines," is applicable.

2.17 Exception to Paving on Rural Minor Access Streets (Residential)

- A. A rural minor access street (residential) as described in Section 2.03 that is a private street shall meet the following standard: It shall be graded and, as minimum treatment, be surfaced full width including shoulders (28 feet) with crushed surfacing material as provided in Section 4.01A Alternative V and Drawing No. 1-004. Half streets shall be surfaced not less than 20 feet wide. Where connecting to a public street the connecting area shall be paved between traveled way and right-of-way line (extended) of the public street, with 25 foot or 35 foot radii as required by Section 2.10. Paving shall be in accordance with Section 4.01A with applicable alternative other than Alternative V.
- B. Any rural minor access street (residential) approved under subsection A above shall remain a private street unless it is upgraded to public street standards at the expense of the subdivider or adjoining lot owners, to include hard surface paving, and accepted by the Engineer for public ownership and maintenance.

2.18 Intersections with State or Federal Highways

In the event that the County has jurisdiction on a development that requires the construction or improvement of a commercial/industrial driveway or any classification of street that intersects a state or federal highway, minimum intersection spacing, entering sight distance and landing requirements in accordance with these Standards shall be satisfied in addition to the requirements of all other applicable permits. In the instance State or Federal standards exceed these Standards, State or Federal standards shall govern.

2.19 Slope, Wall, & Drainage Easements and Right-of-Way Reduction

A. Easements

Either the functional classification or particular design features of a road may necessitate slope, sight distance, wall or drainage easements beyond the right-of-way line. Such easements may be required by the Engineer or Reviewing Agency in conjunction with dedication or acquisition of right-of-way.

B. Right-of-way reduction on subcollectors, local access (residential) and minor access (commercial)

In proposed developments served by underground utilities within easements, the right-of-way may be reduced to the minimum roadway width plus sidewalk, as allowed in Sections 2.03 and 2.04, with the approval of the Reviewing Agency. Where it is desired to reduce right-of-way to a minimum width, the right-of-way, plus easement, shall allow for construction and maintenance of the following as appropriate, sidewalks, planter strips, drainage facilities, sign placement, and also allow sidewalk widening around mailbox locations. On subcollectors, installation of fixed objects, other than required above ground utility structures, greater than four inches in diameter within four feet of back of sidewalk shall not be permitted.

2.20 Access and Circulation Requirements

In order to provide a second access to a residential subdivision, short subdivision, binding site plan or planned unit development, no residential street shall serve more than 100 lots or dwelling units unless the street is connected in at least two locations with another street that functions at a level consistent with Sections 2.02 and 2.03.

A. The second access requirement may be satisfied through use of connecting a new street to an existing street in an adjacent neighborhood if:

1. No other practical alternative exists, or
2. Existing street was previously stubbed indicating intent for future access, or
3. An easement has been recorded specifically for said purpose.

The second access requirement may not be satisfied through use of an existing roadway network in the existing adjacent neighborhood if:

1. A more practical alternative exists, or
2. Existing streets do not meet Section 2.03

These provisions are not intended to preclude the state statute on land-locking.

- B. This section does not preclude a commercial project from gaining access through a residential development. Traffic impacts for such projects will be analyzed during the SEPA process.

2.21 Exception for Maximum Dwelling Units on Urban Subcollectors

Proposed subcollectors serving new urban area developments with an average density of seven to eight dwelling units per acre and which meet the access requirements of Section 2.20 may serve up to 250 single-family dwelling units, if approved by the Reviewing Agency. Prior to approval, the Reviewing Agency may require a traffic circulation study showing a balanced traffic flow of less than 1500 vehicles per day past any access point. Street trees shall be mandatory along subcollectors serving higher densities of seven to eight dwelling units per acre and shall be in conformance with Section 5.03.

CHAPTER 3. DRIVEWAYS, WALKS, & TRAILS

3.01 Driveways

- A. Dimensions, slope, and detail shall be as indicated in Drawings No. 2-001, 3-003, 3-004, 3-005 and 3-006, as further specified in the following subsections. See Section 2.13 for entering sight distance requirements.
- B. Conditions for Approval of New Driveways:
1. Driveways directly giving access onto arterials may be denied if alternate access is available.
 2. All abandoned driveway areas on the same frontage shall be removed and the curbing and sidewalk, or shoulder and ditch section, shall be properly restored.
 3. Maintenance of driveway approaches shall be the responsibility of the owner whose property they serve.
 4. For a commercial establishment on a shoulder and ditch type road, where development of adjoining lands and highway traffic assume urban characteristics as determined by the Reviewing Agency, the frontage shall be finished with curb, gutter, and sidewalk, with pipe drainage, all in accordance with these Standards. Alternatively, the Reviewing Agency may require the entire frontage area to be graded and paved to the right-of-way line with asphalt or portland cement concrete. In such case, surface drainage shall be intercepted and carried in a closed system as set forth in Chapter 7. Access shall be limited by means of a six-inch curbing. See Extruded Asphalt or Cement Concrete Curb detail, Drawing No. 3-002.
 5. For driveways crossing an open ditch section, culverts shall be adequately sized to carry anticipated stormwater flows and in no case be less than 12 inches in diameter. The property owner making the installation shall be responsible for determining proper pipe size. The Reviewing Agency may require the owner to verify the adequacy of pipe size.
- C. Location and Width of New Driveways. Refer to Drawing No. 3-006.
1. A residential driveway shall typically serve only one parcel. A driveway serving more than one parcel shall be classed as a commercial driveway or a private street, except as provided in 3.a. and 3.b. below.
 2. On frontages 75 feet or less, no more than one driveway per lot shall be constructed; on frontages over 75 feet, two or more driveways per lot may be permitted, subject to approval by the Reviewing Agency.

3. No portion of driveway width shall be allowed within 5 feet of side property lines in residential areas or 9 feet in commercial areas except as follows:
 - a. A joint use driveway tract may be used to serve two parcels:
 - (1) Minimum tract width in urban areas shall be 20 feet with an 18 foot paved surface, cross slope in one direction and curb or thickened edge on one side. Minimum tract length shall be 20 feet from right-of-way line. Radius returns on paved apron shall have 10-foot radii.
 - (2) Minimum tract width in rural areas shall be 20 feet; 30 feet if a ditch is required. Minimum tract length shall be 20 feet from right-of-way line. Radius returns on paved apron shall have 10-foot radii.
 - (3) Driving surface (rural areas) shall be 18 feet, paved or gravel, with a paved apron from the edge of pavement of intersecting street to right-of-way line.
 - (4) The Reviewing Agency may allow use of an easement if the only access to a serving roadway is through an adjacent parcel not owned by the applicant or for urban residential short plats to satisfy minimum lot width requirements.
 - b. Driveways may utilize full width of narrow "pipe-stem" parcels or easements if approved by Reviewing Agency.
 - c. On cul-de-sac bulbs as necessary for proposed residential access.
 4. Grade transitions, excluding the tie to the roadway, shall be constructed as smooth vertical curves. Ties to the roadway shall be constructed as shown in Drawings 3-003 and 3-004. The maximum change in driveway grade, within the right-of-way, shall be 8% within any 10 feet of distance on a crest and 12% within any 10 feet of distance in a sag vertical curve. Driveway shall be graded to match into possible future widened road section without encroachment into graded shoulder or sidewalk. The design engineer for proposed developments shall consider the access driveway profile when designing the serving road to ensure that required grade transitions can be complied with considering building set back and lot terrain conditions.
 5. Driveways in rolled curb sections may be constructed abutting and flush with sidewalk or back of curb without gapping or lowering height of curb.
- D. Existing driveways may be reconstructed as they exist provided such reconstruction is compatible with the adjacent road.
- E. For commercial or industrial driveways with heavy traffic volumes or significant numbers of trucks, the Reviewing Agency may require construction of the access as a road intersection. This

requirement will be based on traffic engineering analysis submitted by the applicant that considers, among other factors, intersection spacing, sight distance and traffic volumes.

- F. Notwithstanding any other provisions, driveways will not be allowed where they are prohibited by separate County Council action or where they are determined by the Engineer or Reviewing Agency to create a hazard or impede the operation of traffic on the roadway.

3.02 Concrete Sidewalks

- A. Shall be required on urban category, curb and gutter type streets as follows:

1. On all arterials, neighborhood collectors, subcollectors, multiple-dwelling and business access streets, both sides.
2. On subaccess streets and industrial access streets, one side.
3. On minor access streets (commercial), both sides unless alternative routes are provided for pedestrians.
4. On minor access streets (residential) exceeding 150 feet and on any cul-de-sacs with off-street walkways extending from their termini to other streets, parks, schools, bus stops, or other pedestrian traffic generators, one side. On cul-de-sacs, sidewalks shall extend around bulb to intersect off-street walkway. Other extended off-street walkways may be required by the Reviewing Agency to provide direct connections for ease and safety of pedestrians.

- B. Shall be constructed:

1. Next to the curb unless planting strips are part of the design and are approved by the Engineer as part of a landscaping plan.
2. Back of planting strips where planting strips are to be constructed.
3. At least five feet wide on residential and commercial access streets. This means five feet clear of mailboxes or other obstructions, except where approved as a variance. Width shall be minimum six and one-half feet on arterials if curb is next to traveled lane (but not necessary next to designated parking or bike lanes). The additional width, one and one-half feet or more, may be finished to match the sidewalk or may be finished with contrasting texture, asphalt concrete, brick, or paving blocks as approved by the Reviewing Agency or Engineer.
4. At least eight feet wide:
 - a. In business/commercial districts where most of the store frontage is within 80 feet of the street right-of-way.

- b. Within the curb radius returns of all arterial intersections where curb ramps are required.
 - c. Within designated bus zones to provide a landing area for wheel chair access to transit services.
5. With specified width greater than eight feet where Engineer or Reviewing Agency determines this is warranted by expected pedestrian traffic volume.
 6. With portland cement concrete surfacing as provided in Sections 3.03 and 4.01. See specifications for joints in Section 3.04 and Drawing No. 3-001.

3.03 Curbs, Gutters and Sidewalks

- A. Subgrade compaction for curbs, gutters, and sidewalks shall meet a minimum 90 percent of maximum density.
- B. Concrete for curbs, gutters, and sidewalks shall be Class 3000, furnished and placed in accordance with WSDOT/APWA Standard Specifications, Sections 6-02, 8-04, and 8-14. Cold weather precautions as set forth in WSDOT/APWA Standard Specifications Sections 5-05.3(14) and 6-02.3(6)A shall apply.
- C. Extruded cement concrete curb shall be anchored to existing pavement by either steel tie bars or adhesive in conformance with WSDOT/APWA Standard Specification Section 8-04.
- D. Extruded asphalt curbs shall be anchored by means of a tack coat of asphalt in accordance with WSDOT/APWA Standard Specification Section 8-04.

3.04 Expansion and Dummy Joints. See Drawing No. 3-001.

- A. An expansion joint consisting of 3/8" or 1/4" x full depth of premolded joint material shall be placed around fire hydrants, poles, posts, and utility castings and along walls or structures in paved areas. Joint material shall conform to the requirements of ASTM D994 (AASHTO M33).
- B. A dummy joint consisting of 3/8" or 1/4" x 2" of premolded joint material shall be placed in curbs and sidewalks at a minimum of 15 foot intervals and at sides of drainage inlets. When curbs and/or sidewalks are placed by slip-forming, a premolded strip up to 1/2" thick and up to full depth may be used.
- C. Dummy joints in sidewalk shall be located so as to match the joints in the curb whether sidewalk is adjacent to curb or separated by planting strip.
- D. Tool marks consisting of 1/4" V-grooves shall be made in sidewalk at five foot intervals, intermediate to the dummy joints.

- E. As alternative to expansion joints around structures, reinforcing bars may be embedded in concrete on four sides of structures.
- F. Interface between curb and adjacent sidewalk on integral pour construction shall be formed with 1/4" radius edging tool. On separate pour construction an expansion joint consisting of 3/8" or 1/4" x full depth of premolded joint material shall be placed between the curb or thickened edge and the adjacent sidewalk.

3.05 Curb Ramps

On all streets with vertical or rolled curb, ramped sections to facilitate passage of handicapped persons shall be constructed through curb and sidewalk at street intersections and other crosswalk locations. See Drawings No. 4-002 and 4-003. Where a ramp is constructed on one side of the street, a ramp shall also be provided on the opposite side of the street. Curb ramps shall be positioned so that a ramp opening is situated within the marked crosswalk or crossing area if unmarked.

3.06 Concrete Steps, Metal Handrail and Handicapped Access Ramps

- A. Steps shall only be used where acceptable alternative access is available for handicapped access and there is a need for a separate stairway. Where used, concrete steps shall be constructed in accordance with Drawing No. 5-008 or other design acceptable to the Engineer or Reviewing Agency and consistent with the WSDOT/APWA Standard Specifications. Handrails, whether for steps or other applications, shall be provided consistent with Drawing No. 5-008 and the WSDOT/APWA Standard Specifications.
- B. Ramps used to provide handicapped access shall have a maximum slope of 12:1 with a maximum rise of 30 inches between landings. Landings shall have a minimum length of five feet and should be of sufficient width to allow wheelchairs to pass, generally five feet minimum width for two way traffic.

3.07 Asphalt Shoulders

- A. In urban areas, asphalt paved shoulders may be used where approved by the Engineer or Reviewing Agency on existing roads to provide for bicycle and pedestrian use as specified in Section 1.03B and to provide continuity of design. When allowed, paved shoulders shall be placed in conformance with Sections 2.02 and 2.03.
- B. In rural areas, asphalt paved shoulders which may serve as walkways and bikeways, shall be provided on both sides of any arterials or other roads designated in the King County Nonmotorized Transportation Plan or as directed by the Engineer or Reviewing Agency.
- C. Where shoulders are paved on one side only, they shall be delineated by a four-inch white thermoplastic edge line.

3.08 Separated Walkways, Bikeways and Trails

Separated pedestrian, bicycle and equestrian trails shall be provided where designated in community and functional plans or where required by the Engineer or Reviewing Agency because of anticipated significant public usage. Separated facilities are typically located on an easement or within the right-of-way when separated from the roadway by a drainage ditch or barrier. Where separate walkways, bikeways, or equestrian trails intersect with motorized traffic, sight distance, marking and signalization (if warranted) shall be as provided in MUTCD. Facilities shall be designed as follows:

- A. Separated asphalt walkways are designed primarily for pedestrians and are typically located within the right-of-way or easement. Minimum width shall be five feet with asphalt surfacing as indicated in Section 4.01D.
- B. Neighborhood pathways are soft surface facilities designed for pedestrians and equestrians. Such pathways shall be a minimum four feet wide with at least one and one-half foot clearance to obstructions on both sides and 10 foot vertical clearance. Pathways shall be designed and located so as to avoid drainage and erosion problems. Pathways shall be constructed of two and one-half inches of crushed surfacing top course or wood chips over cleared native material as approved by the Reviewing Agency.
- C. Multi-purpose trails are typically designated for bicycle and pedestrian use and in general follow a right-of-way independent from any road. Multi-purpose trails shall be designed to bicycle path standards as described in Section 3.10.

3.09 School Access

School access required as part of development approval shall be provided by an asphalt walkway, concrete sidewalk or full width delineated shoulder unless another alternative is available and approved by the Engineer through a road variance request.

3.10 Bikeways

- A. Bikeways are generally shared with other transportation modes, although they may be provided exclusively for bicycle use. Bikeways are categorized below based on degree of separation from motor vehicles and other transportation modes. This classification does not denote preference of one type over another. Bikeways are categorized as follows:
 - Bike Path (Class I): A separate paved multipurpose trail for the principal use of bicycles and other nonmotorized modes. Bike paths are 10 feet wide except in high usage areas where they should be 12 feet wide.
 - Bike Lane (Class II): A portion of the road that is designated by pavement striping for exclusive bicycle use. Bicycle lanes may be signed as part of a directional route system. Bicycle lanes are five feet wide on a curbed road and minimum four feet wide as a shoulder bike lane.

Wide Curb Lane (Class III): A road that provides a widened paved outer curb lane to accommodate bicycles in the same lane as motor vehicles. Lane width shall be increased at least three feet.

Shoulder: A lane contiguous to the traveled way but separated by a stripe. Most common in rural areas. Typically shared with pedestrians and occasional emergency vehicle access.

Shared Roadway: All roads not categorized above where bicycles share the roadway with motor vehicles.

B. A bikeway shall be provided:

1. Wherever called for in the Nonmotorized Transportation Plan, King County Transportation Plan, King County Comprehensive Plan, community plan, Capital Improvement Program or Transportation Needs Report.
2. When substantial bike usage is expected which would benefit from construction of a bicycle facility.

C. Striping and signing shall be implemented as follows:

1. Pavement markings shall be used on bike lanes and paths according to MUTCD.
2. The design of all signalized intersections shall consider bicycle usage and the need for bicyclists to actuate the signal.

D. The planning and design of bikeways in any category shall be in accordance with Section 1020 of the WSDOT Design Manual and the AASHTO Guide for the Development of Bicycle Facilities, current edition.

3.11 Equestrian Facilities

A. Equestrian facilities adjacent to the traveled way shall be provided where proposed by the King County Nonmotorized Transportation Plan or as required by the Engineer or Reviewing Agency. Facilities shall be provided as follows:

1. Shoulders adjacent to the traveled way intended for equestrian use shall be surfaced full-width, minimum four feet with eight feet desirable. Surface shall be two and one-half inches of crushed surfacing base course and one and one-half inches of crushed surfacing top course.

2. A separated equestrian trail shall be constructed with an 18 percent maximum grade, 10-foot vertical clearance and a five-foot wide pathway zone. The trail shall be constructed of native soil or, where drainage or erosion problems are present, a minimum of two and one-half inches of crushed surfacing top course on graded and compacted native soil. Native soil which is not free draining shall be removed and replaced with free draining soil as necessary to provide a maintainable and well-drained subgrade. Additional crushed surfacing, cinders or other stabilizing materials shall be required if heavy usage is anticipated or if there is any evidence of instability in the subgrade; including free water, swamp conditions, fine-grained or organic soils, slides or uneven trails.

CHAPTER 4. SURFACING

4.01 Residential Streets, Pedestrian and Bike: The minimum paved section, with alternative combinations of materials, for residential streets, shoulders, sidewalks and bikeways shall be as indicated below. These sections are acceptable only on visually good, well-drained, stable compacted subgrade. Any proposed exception to these materials will be subject to soils strength testing and traffic loading analysis and subject to review and approval by the Engineer as outlined in Section 4.02 below. All expenses for determining revised materials shall be borne by the Developer.

TYPE OF FACILITIES	ASPHALT CONCRETE	ASPHALT TREATED BASE	BITUMINOUS SURFACE TREATMENT	CRUSHED SURF. TOP COURSE	CRUSHED SURF. BASE COURSE	PORTLAND CEMENT CONCRETE
A. RESIDENTIAL ACCESS STREETS						
Alternative I	2" (3"*)	4"				
Alternative II	2" (3"*)			1½"		.5"
Alternative III (Acceptable for rural areas, transitional areas, and designated agricultural production districts only, on grades not steeper than 12 percent)			Class A	1½"		.5"
Alternative IV						Class 4000, 7" (8"*)
Alternative V (Acceptable on rural minor access streets)				1½"		2½"
*On neighborhood collectors						
B. SHOULDERS						
Alternative I	2" (3"*)	4"				
Alternative II	2" (3"*)			1½"		2½"
Alternative III			Class A	1½"		2½"
Alternative IV				1½"		2½"
*On bus routes						
C. SIDEWALKS						
Alternative I (Acceptable except behind rolled curb)						Class 3000, 4"

TYPE OF FACILITIES	ASPHALT CONCRETE	ASPHALT TREATED BASE	BITUMINOUS SURFACE TREATMENT	CRUSHED SURF. TOP COURSE	CRUSHED SURF. BASE COURSE	PORTLAND CEMENT CONCRETE
--------------------	---------------------	----------------------------	------------------------------------	--------------------------------	---------------------------------	--------------------------------

Alternative II
(Mandatory behind rolled
curb) Class 3000, 5"

D. WALKWAYS & BIKEWAYS

Alternative I	2"			1½"	2½"	
Alternative II	3½"					
Alternative III			Class A	1½"	2½"	
Alternative IV						Class 3000, 5"
Alternative V	(may be used as shown on Dwg. No. 1-005 and 1-006 or where approved by Reviewing Agency).					2"

When a walkway or bikeway is incorporated into a road shoulder, the required shoulder section, if higher strength, shall govern. Subgrade compaction for bikeways and paved walkways shall meet a minimum of 90 percent maximum density.

E. DRIVEWAYS may be surfaced as desired by the owner, except:

1. On curbed streets with sidewalks, driveway shall be paved with portland cement concrete Class 4000 from curb to back edge of sidewalk. See Drawings No. 3-004 and 3-005.
2. On shoulder and ditch section, driveway between edge of pavement and right-of-way line shall be surfaced as required by Drawing No. 3-003.
3. On thickened edge roadways with underground utilities, portland cement concrete may be used for driveways between the thickened edge and the right-of-way line provided that a construction joint is installed at the right-of-way line.

F. STREET WIDENING/ADDING TRAVELED WAY TO EXISTING ROADS

1. When an existing asphalt paved street is to be widened, the edge of pavement shall be saw cut to provide a clean, vertical edge for joining to the new asphalt. After placement of the new asphalt section, the joint shall be sealed and the street overlaid one inch, plus a prelevel course, full width throughout the widened area. The requirement for overlay may be waived by the Engineer or Reviewing Agency based on the condition of existing pavement and the extent of required changes to channelization.

2. When an existing shoulder is to become part of a proposed traveled way a pavement evaluation shall be performed. This evaluation shall analyze the structural capacity and determine any need for improvement. Designs based on these evaluations are subject to review and approval by the Engineer or Reviewing Agency. The responsibility for any shoulder material thickness improvement shall be considered part of the requirement for roadway widening. The shoulder shall be replaced in width as specified in Sections 2.02, 2.03 and 2.04.
3. Any widening of an existing roadway, either to add traveled way or paved shoulder shall have the same surfacing material as the existing roadway.

4.02 Requirements for Residential Streets on Poor Subgrade

The minimum material thicknesses indicated in Section 4.01 are not acceptable if there is any evidence of instability in the subgrade. This includes free water, swamp conditions, fine-grained or organic soil, slides or uneven settlement. If there are any of these characteristics, the soil shall be sampled and tested sufficiently to establish a pavement design that will support the proposed construction. Any deficiencies, including an R value of less than 55 or a CBR of less than 20, shall be fully considered in the design. Remedial measures may include, but are not limited to, a stronger paved section, a strengthening of subgrade by adding or substituting fractured aggregate, asphalt treated base, installing a geotextile, more extensive drainage or a combination of such measures. Both the soils test report and the resulting pavement design will be subject to review and approval by the Engineer or Reviewing Agency.

4.03 Arterials and Commercial Access Streets

Any pavement for arterials and commercial access streets shall be designed using currently accepted methodology that considers the load bearing capacity of the soils and the traffic-carrying requirements of the roadway. Plans shall be accompanied by a pavement thickness design based on soil strength parameters reflecting actual field tests and traffic loading analyses. The analysis shall include the traffic volume and axle loading, the type and thickness of roadway materials and the recommended method of placement. Pavement sections shall not be less than those required for neighborhood collectors.

4.04 Materials & Lay-Down Procedures: Shall be in accordance with WSDOT/APWA Standard Specifications and the following requirements:

- A. Crushed surfacing top and base courses may be substituted for a structurally equivalent thickness of ATB. The substitution ratio of crushed surfacing to ATB shall be 1.6:1. Where base or top courses cannot be placed without possible contamination, then these courses shall be substituted by ATB.
- B. During surfacing activities utility covers in roadway shall be adjusted in accordance with Section 8.04.
- C. ATB may be used over isolated areas of unstable subgrade, providing the final lift of asphalt shall not be placed for a minimum of six months to allow time for the observation and repair of failures in the subgrade and ATB.

D. Asphalt pavers shall be self contained, power propelled units. Truck mounted type pavers are not considered self propelled. Truck mounted pavers shall only be used for paving of irregularly shaped or minor areas as approved by the Engineer, or as follows:

1. pavement widths less than eight feet; and
2. pavement lengths less than 150 feet.

4.05 Pavement Markings, Markers, and Pavement Tapers

Pavement markings, markers or striping shall be used to delineate channelization, lane endings, crosswalks and longitudinal lines to control or guide traffic. Channelization plans or crosswalk locations shall be approved by the Traffic Engineer.

Channelization shall be required when through traffic is diverted around a lane or obstacle; and when connecting full width streets with different cross sections; and when extending an existing street with a new cross section different than the existing one. The channelization shall provide tapers equal in length to the posted speed limit times the distance in feet of diversion from the road centerline or the original alignment of travel, or the offset distance, as applicable. Channelization shall also be required to redirect traffic back to their original alignment.

Left turn channelization shall include a minimum of 150 feet of full width lane to include storage and a reverse curve 90 feet in length for posted speeds up to 45 mph. The reverse curve shall be 120 feet in length for posted speeds greater than 45 mph. The reverse curve may be included within the taper distance. A deceleration taper as shown in the WSDOT/APWA Standard Plans may be used in place of a reverse curve. Standard left turn lanes shall be 12 feet wide. Type 2L arrows shall be installed in the lane 25 feet and 100 feet behind the stop bar, crosswalk or stopping area. Additional storage may be required for long vehicles or anticipated left turn queues longer than the minimum storage.

Centerline for channelization shall consist of two four-inch yellow lines with a four-inch separation. Type 2d lane markers shall be installed at 40 foot centers between the lines. Holding lines for additional lanes shall be eight-inch white lines with Type 2e lane marker on the inside of the lane at 20 foot centers. Edgelines for tapering thru traffic back to the original alignment shall consist of four-inch white lines.

Pavement markings for channelization shall be reflectorized hot or cold applied plastic. Extruded or sprayed markings shall be dressed with glass beads for initial reflectance. All materials shall have beads throughout the material to maintain reflectance while the material wears.

Where pavement widening less than 300 feet in length is abruptly ended and edge lines do not direct traffic to through lanes, Type 2e lane markers shall be installed at 10 foot centers near the end of the paved area at a 10:1 taper.

Crosswalks shall be installed at all intersections controlled by traffic signals and other areas approved by the Traffic Engineer. Crosswalks shall consist of sets of longitudinal lines eight inches wide by 10 feet and with eight-inch separation. A set of these lines shall be installed between each lane, between the wheel tracks in each lane and at the pavement edges.

All pavement markings shall be laid out with spray paint and approved by the Traffic Engineer before they are installed. Approval may require a three working day advance notice to have field lay-out approved by the Traffic Engineer or to make arrangements to meet the Traffic Engineer on site during the installation.

CHAPTER 5. ROADSIDE FEATURES

5.01 Rock Facings

- A. Rock facings may be used for the protection of cut or fill embankments up to a maximum height of eight feet above the keyway in stable soil conditions which will result in no significant foundation settlement or outward thrust upon the walls. See Drawing Nos. 5-004 through 5-006. For heights over eight feet above the keyway or when soil is unstable, a structural wall of acceptable design shall be used. As an exception, rock facing heights may exceed eight feet to a limited extent based on favorable soils analyses and a design by a geotechnical engineer or other professional engineer qualified in rock wall design, subject to approval by the Engineer. Terracing of rockeries subject to approval by the Engineer.
- B. **Materials**
1. Size categories shall include:
Two-man rocks (200 to 700 pounds), 18"-28" in average dimension;
Three-man rocks (701 to 2000 pounds), 28-36" in average dimension; and
Four-man rocks (2001 to 4000 pounds), 36-48" in average dimension.

Four-man rocks shall be used for bottom course rock in all rock facings over six feet in height.
 2. The rock material shall be as nearly rectangular as possible. No stone shall be used which does not extend through the wall. The quarried trap rock shall be hard, sound, durable and free from weathered portions, seams, cracks and other defects. The rock density shall be a minimum of 160 pounds per cubic foot, measured according to WSDOT Test Method 107 (Bulk Specific Gravity - S.S.D. basis). Additionally, rock subjected to the U.S. Army Corps of Engineers Test Method CRD-C-148 ("Method of Testing Stone for Expansive Breakdown on Soaking in Ethylene Glycol") must have less than 15 percent breakdown.
- C. **Keyway**
- A keyway consisting of a shallow trench of minimum 12-inch depth shall be constructed the full rockery length, and slightly inclined towards the face being protected. It shall be excavated the full rockery width including the rock filter layer. The keyway subgrade shall be firm and acceptable to the engineer. See Drawing No. 5-004.
- D. **Underdrains**
1. A minimum six-inch diameter perforated or slotted drain pipe shall be placed in a shallow excavated trench located along the inside edge of the keyway. The pipe shall be bedded on and surrounded by "Gravel Backfill for Drains" (WSDOT/APWA 9-03.12(4)) to a minimum height of 18

inches above bottom of pipe. A filter fabric shall surround the gravel backfill and shall have a minimum one-foot overlap along the top surface of the gravel. This requirement for fabric may be waived by the Engineer if shown that soils and water conditions make it unnecessary. See Drawing Nos. 5-004 through 5-006.

2. The perforated pipe shall be connected to the storm drain system or to an acceptable outfall.

E. **Rock Selection and Placement:** Rock selection and placement shall be such that there will be minimum voids and, in the exposed face, no open voids over six inches across in any direction. The final course shall have a continuous appearance and be placed to minimize erosion of the backfill material. The larger rocks shall be placed at the base of the facing so that it will be stable and have a stable appearance. The rocks shall be placed in a manner such that the longitudinal axis of the rock shall be at right angles to the face. The rocks shall have all inclined faces sloping to the back of the facing. Each course of rocks shall be seated as tightly and evenly as possible on the course beneath. The rocks shall be placed so that there are no continuous joint planes either horizontally or vertically. After setting each course of rock, all voids between the rocks shall be chinked on the back with quarry rock to eliminate any void sufficient to pass a two-inch square probe. See Drawing Nos. 5-004 through 5-006.

F. **Rock Filter Layers:** The rock filter layer shall consist of quarry spalls with a maximum size of four inches and a minimum size of two inches. This material shall be placed to a 12-inch minimum thickness between the entire facing and the cut or fill material. The backfill material shall be placed in lifts to an elevation approximately six inches below the top of each course of rocks as they are placed, until the uppermost course is placed. Any backfill material on the bearing surface of one rock course shall be removed before setting the next course.

G. **Fill Rockery Facing Supporting Roadway Embankment:** Embankment behind rockeries exceeding four feet in height above the keyway shall be reinforced with a geosynthetic fabric or geogrid specifically manufactured for soil reinforcement, designed on a project specific basis by a qualified engineer. See Drawing No. 5-007.

H. **Sidewalks Above Rockery Facings:** When a sidewalk is to be built over a rock facing, the top of the facing shall be sealed and leveled with a cap constructed of cement concrete Class 3000 in accordance with the applicable provisions of Section 6-02 of the WSDOT/APWA Standard Specifications, but with reduced water content resulting in slump of not over two inches. See Drawing No. 5-006.

I. **Fences and Handrails**

A chain link fence or metal handrail shall be installed when rockery is three feet or greater in height. (See Drawing Nos. 5-004 through 5-006 and 5-008)

5.02 Side Slopes

- A. Side slopes shall generally be constructed no steeper than 2:1 on both fill slopes and cut slopes. Steeper slopes may be approved by the Engineer upon showing that the steeper slopes, based on soils analyses, will be stable. Side slopes on projects funded by federal grants shall be constructed in conformance with Local Agency Guidelines.
- B. Side slopes shall be stabilized by grass sod or seeding or by other planting or surfacing materials acceptable to the Engineer.

5.03 Street Trees & Landscaping

- A. Street trees and landscaping should be incorporated into the design of road improvements for all classifications of roads. Such landscaping in the right-of-way shall be coordinated with off-street landscaping required on developer's property under the provisions of King County Code Chapter 21.51.
- B. Planting strips are optional along all classifications of roads and may be considered as part of the landscape mitigation requirements established during the SEPA review process. The design of planting strips must be approved by the Engineer and must include a landscaping plan in which plant maintenance, utilities and traffic safety requirements are discussed.
- C. Existing trees and landscaping shall be preserved where desirable and placement of new trees shall be compatible with other features of the environment. In particular, maximum heights and spacing shall not conflict unduly with overhead utilities, or root development with underground utilities. If street trees are planted, they shall conform reasonably to standards in Drawing No. 5-009.
- D. New trees shall not include poplar, cottonwood, soft maples, gum, any fruit bearing trees or any other tree or shrub whose roots are likely to obstruct sanitary or storm sewers. See King County Code 13.04.230.
- E. Street tree plans on bus routes shall be reviewed by Metro Service Planning, phone 684-1622.

5.04 Mail Boxes

- A. The responsibilities for location and installation of mailboxes in connection with the construction or reconstruction of County roads are as follows:
 - 1. County Road Engineer or his representative will:
 - a. Require road improvement plans, whether for construction by the Department of Public Works or by a private builder, to show clearly the designated location or relocation of mailboxes, whether single or in clusters.

- b. Require with this information any necessary widening or reconfiguration of sidewalks with suitable knock-outs or open strips for mailbox posts or pedestal.
 - c. Require these plans to bear a statement on the first sheet that mailbox locations as shown on these plans have been coordinated with the serving post office at (City/Community), Washington. This will be a prerequisite to plan approval.
 - d. Require construction of mailbox locations in accordance with these plans, through usual inspection and enforcement procedures.
2. Seattle Postmaster or designated serving post office will:
- a. Designate location and manner of grouping of mailboxes when so requested by the design agency. Note on the plans the type of mailbox delivery: NDCBU (Neighborhood Delivery and Collection Box Unit), or Rural type box. Authenticate by stamp or signature when these data have been correctly incorporated into the plans.
 - b. Do all necessary coordination with owners or residents involved to secure agreement as to mailbox location and to instruct them regarding mailbox installation. Actually install or relocate NDCBU's if these are the type of box to be used in the neighborhood.
3. Owners or residents served by mailboxes, at time of original installation, will:
- a. If using individual mailboxes, clustered or separate, install and thereafter maintain their own mailboxes as instructed by the post office.
 - b. If NDCBU delivery, rely on Post Office to provide and maintain NDCBU's.
4. Builders or their contractors shall:
- a. Where there are existing mailboxes and no plans to replace them with NDCBU's:

When it becomes necessary to remove or otherwise disturb existing mailboxes within the limits of any project, install the boxes temporarily in such a position that their function will not be impaired. After construction work has been completed, reinstall boxes at original locations or at new approved locations as indicated on the plans or as directed by the Engineer or Reviewing Agency. Use only existing posts or materials except that any damage caused by the builder or his contractor is to be repaired at the expense of the builder.
 - b. Where there are existing NDCBU's or plans to install NDCBU's:

Call on Seattle Postmaster or designated serving post office to locate or relocate NDCBU's and make the necessary installation.

B. Installation methods are as follows:

1. Mailboxes, in the general case, shall be set in accordance with Drawing No. 5-010 or 5-011. Boxes shall be clustered together when practical and when reasonably convenient to the houses served.
2. NDCBU's will be installed by the Postal Service generally in accordance with Drawing No. 5-012.

5.05 Street Illumination

Continuous illumination will be required for channelization accommodating additional lanes including the tapers. Illumination will also be required as identifiers where roads intersect arterials or for frequently used pedestrian areas on arterials.

Widening of arterials with existing continuous illumination will require maintaining the continuous illumination. Widening to the ultimate roadway width will require illumination designed to current construction practices.

Illumination intensity and uniformity shall conform with current King County design practices. Luminaire fixtures shall be consistent with fixtures maintained by the local electrical utility.

5.06 Survey Monuments

- A. All existing survey monuments which are disturbed, lost, or destroyed during surveying or building shall be replaced by a land surveyor registered in the State of Washington at the expense of the responsible builder or developer.
- B. Survey monuments shall be placed or replaced in accordance with recognized good practice in land surveying, and in conformance with Drawings No. 5-014 and 5-015.

5.07 Roadway Barricades

Temporary and permanent barricades shall conform to the standards described in Section 6C-8 of the Manual on Uniform Traffic Control Devices (MUTCD) and Drawing No. 5-003.

- A. Type I or Type II barricades may be used when traffic is maintained through the area being constructed/reconstructed.
- B. Type III barricades may be used when roadways and/or proposed future roadways are closed to traffic. Type III barricades may extend completely across a roadway (as a fence) or from curb to curb. Where provision must be made for access of equipment and authorized vehicles, the Type III barricades may be provided with movable sections that can be closed when work is not in progress, or with indirect

openings that will discourage public entry. Where job site access is provided through the Type III barricades, the developer/contractor shall assure proper closure at the end of each working day.

- C. In the general case, Type III permanent barricades shall be installed to close arterials or other through streets hazardous to traffic. They shall also be used to close off lanes where tapers are not sufficiently delineated.
- D. Type III barricades shall be used at the end of a local access street terminating abruptly without cul-de-sac bulb or on temporarily stubbed off streets. Each such barricade shall be used together with an end-of-road marker.

5.08 Bollards

When necessary to deny motor vehicle access to an easement, tract, or trail, except for maintenance or emergency vehicles, the point of access shall be closed by a line of bollards. These shall include one or more fixed bollards on each side of the traveled way and removable, locking bollards across the traveled way. Spacing shall provide one bollard on centerline of trail and other bollards spaced at minimum 50 inches on center on trails 10 feet wide or less. Spacing shall be 60 inches on center on trails wider than 10 feet. Bollard design shall be in accordance with Drawing No. 5-013 or other design acceptable to the Engineer or Reviewing Agency. No fire apparatus access roads shall be blocked in this manner without the concurrence of the Fire Marshal. Bollards shall be located at least 10 feet laterally from the paved edge of roadway.

5.09 Guardrail/Embankment Heights

Guardrail installations shall conform to WSDOT/APWA Standard Plan C-1, Beam Guardrail Type 1 and C-2, Guardrail Placement. End anchors shall conform to WSDOT/APWA Standard Plan C-6, Beam Guardrail Anchor Type 1.

Evaluation of embankments for guardrail installations shall be in accordance with Figure 710-6 of the WSDOT Design Manual.

5.10 Off-Street Parking Spaces

The number of off-street parking spaces required shall conform to King County Code Title 21.50. The specifications for off-street parking spaces shall be as provided in King County Code Title 16.74 and implementing document entitled "King County Specifications for Off-Street Parking, 1982," as updated.

5.11 Roadside Obstacles

Non-yielding or non-breakaway structures, including rockeries and retaining walls, which may be potential hazards to the traveling public shall be placed with due regard to safety. On roads with a shoulder or mountable curb, hazardous objects shall be placed as close to the right-of-way line as practicable and a minimum of 10 feet from the edge of the traveled way or auxiliary lane. On urban roads with a vertical

curb section, hazardous objects shall be placed as far from the edge of the traveled way or auxiliary lane as practical. Such an object shall not be placed in a sidewalk or with the object edge nearest the roadway less than eight and one-half feet from the face of the curb in business areas or five and one-half feet from face of curb in residential areas. Placement of any utility structures shall be in accordance with requirements of Chapter 8, to include constraints on placement of poles on the outside of curves.

CHAPTER 6. BRIDGES

6.01 Principal References

Except as specified below, King County bridges, whether on public roads or on private roads serving subdivided land, shall be designed and constructed to meet the minimum requirements set forth in the latest edition, including all interim addenda, of "Standard Specifications for Highway Bridges," adopted by AASHTO and in accordance with the requirements of WSDOT/APWA Standard Specifications. Bridge and approach railings shall be provided in accordance with those references or with WSDOT/APWA Standard Plans. All new bridges shall be designed to carry an AASHTO HS 20-44 live load or greater. All bridge work shall comply with K.C.C. 21.54 regarding Special Control Areas and Flood Hazard Areas for stream and wetland protection and flooding concerns.

6.02 Bridge Geometrics

- A. In the general case, the bridge shall comprise the full width and configuration of the road being served -- traveled way plus curb, sidewalks, walkway, bike lane, equestrian lane and/or shoulder on one or both sides. Requirements of utilities shall be duly considered. Bridge roadway width shall be measured between curbs or between faces of rails, whichever is less, but in no case shall be less than 28 feet.
- B. Where typical speed is 35 MPH or higher and significant pedestrian, bike and/or horseback traffic can be expected, the Engineer may require that the lanes for these other modes of traffic be separated from motor vehicle traffic by use of a bridge traffic rail and further protected by a rail at outer edge. On designated bike routes, combination traffic and bicycle railings shall be used.
- C. Approach railings shall be made structurally continuous with bridge railings and shall meet AASHTO specifications as cited in Section 6.01 above.
- D. Overhead vertical clearances for motor traffic on the traveled way or under overpasses shall be 16.5 feet minimum. Vertical clearance of structures above a walkway or sidewalk shall be eight feet minimum and shall be 10 feet on designated equestrian routes.
- E. The height of bridge clearance above streams shall be as required by the Surface Water Design Manual.

6.03 Bridge Design Criteria

- A. Approach slabs will be required for all bridges and new bridge plans shall provide pavement seats for approach slabs unless otherwise approved by the Engineer. Waiver or modification of the requirement for approach slabs will be considered only on the basis of adequate geotechnical analysis. Approach slabs shall be constructed in accordance with WSDOT/APWA Standard Plan A-2.

- B. New bridge decks and approach slabs shall be designed with a protective system to prevent corrosion of the reinforcing steel.
- C. Criteria under other recognized road and bridge project classifications, such as those of 3-R projects, set forth in WSDOT Local Agency Guidelines, may be applied under conditions deemed appropriate by the Engineer.
- D. The design of bridge expansion joints shall consider the presence of bicycle traffic.

6.04 Special Permits

Permit requirements for construction or reconstruction of bridges include but are not limited to the following:

- A. Bridges over navigable waters require U. S. Coast Guard permits.
- B. Bridges involving deposition of material in waters of the United States or their adjacent wetlands require a U. S. Army Corps of Engineers Permit.
- C. Any work involving alteration of flow or bed materials below the ordinary high water line of any water body or water course requires a Hydraulic Project approval from the State Department of Fisheries or the State Department of Wildlife.
- D. Any work within waters of the State requires a Water Quality Certification Waiver from the State Department of Ecology.
- E. Where bridge structures lie on or over submerged lands a lease from the Washington State Department of Natural Resources may be necessary.
- F. Structures located on shoreline zones as defined in King County Code Title 25 require a substantial development permit from the King County Department of Development and Environmental Services, subject to concurrence of the State Department of Ecology.
- G. Bridges over waterways require the Engineer's approval of the size and shape of the hydraulic opening, the height of the superstructure over high water, the location of piers, channel improvement, and other hydraulic considerations.

CHAPTER 7. DRAINAGE

7.01 General

- A. Designs: Drainage facilities shall be designed consistent with King County Code 9.04 and the King County Surface Water Design Manual, latest edition. Structures shall be placed and constructed as shown in the Standard Drawings.
- B. Specifications: Materials, construction, and testing are specified in the WSDOT/APWA Standard Specifications. The Engineer may amend, delete, or add specifications or Standard Drawings.
- C. Conflicts: Where technical conflicts may occur between this document and the Surface Water Design Manual the Engineer shall decide which document governs.

7.02 Road Ditches

The following standards shall only apply in design of drainage ditches not requiring drainage review under the provisions of the Surface Water Design Manual.

- A. On grades up to 6 percent, grass lined ditches with grasses as specified in 7.02D shall be used for the drainage requirement. These ditches shall be designed and constructed in accordance with Drawings No. 1-001, 1-004 and 1-007. If grass cannot be readily established by usual seeding method, other methods such as sodding or seeding with slope mat protections shall be used as necessary. For grades between 3 percent and 6 percent, grass lining alone may not be sufficient to stop erosion. Preferred methods to further reduce potential erosion problems include the use of check dams or wider ditch sections. Rock-lined ditches shall be avoided whenever possible.
- B. Where the grade is over 6 percent and not over 9 percent, the Engineer may direct use of a standard rock-lined ditch or alternatively a closed (pipe) drainage system under a paved shoulder with asphalt curb or turnpike shoulder. As an exception, cul-de-sacs with over 6 percent grade shall be provided with pipe drainage and not with rock-lined ditches.
 - 1. The standard rock lining shall be in accordance with the Surface Water Design Manual and Section 9-13.6 of the WSDOT/APWA Standard Specifications. Rock gradation shall be as follows:

Passing 8-inch square sieve	100 percent
Passing 3-inch square sieve	40 percent max.
Passing 3/4-inch square sieve	10 percent max.
 - 2. Rocks shall be placed so as to form a firm, dense, protective mat consistent with examples in Drawing No. 2-024 and conforming to the design surface of the ditch. Individual rocks shall not protrude more than three inches from that surface.

- C. Where the grade exceeds 9 percent either pipe drainage or a special rock-lined ditch shall be provided unless otherwise approved by the Engineer. The special rock-lined ditch shall be designed by a professional engineer, based on soils and hydraulic analyses. Design shall include rock sizing, together with filter rock gradations and/or filter fabric, and be subject to approval by the Engineer.
- D. Grass seed mixture by weight may be 10 percent Colonial bentgrass, 40 percent Tall or Red fescue, 10% White clover, hydroseed at 120 lbs./acre, handseed at 3 lbs./1,000 square feet. Where there is high groundwater, the following species may be substituted or added: Meadow or Pacific foxtail, Timothy, or Redtop.

7.03 Storm Sewers and Culverts

- A. Minimum pipe size shall be 12-inch diameter. Eight-inch diameter may be permitted on cross street laterals less than 66 feet long to avoid utility conflict or meet shallow gradient.
- B. Where the time of concentration creating the greatest flow is less than 15 minutes and the system predominately serves the road, determine flow rates using the rational formula.
- C. Driveway culverts shall conform to Drawing No. 3-003.
- D. The following pipes, specified in Section 9-05 of the WSDOT/APWA Standard Specifications are allowed: plain and reinforced concrete storm sewer pipe, aluminized Type 2 corrugated steel, steel spiral rib and corrugated steel with asphalt coating Type 1, spiral rib and corrugated aluminum, ductile iron, polyvinyl chloride (PVC), lined corrugated polyethylene (LCPE) and solid wall polyethylene (SWPE) pipe.
- E. LCPE pipe shall have a smooth interior wall meeting or exceeding Type III, Category 4 or 5, Grade P33 or P34, Class C per ASTM D1248, minimum cell Class ASTM D3350, 324420C. LCPE shall also meet or exceed the requirements of AASHTO M294, Type S. Pipe shall be placed in accordance with County Specifications.
- F. SWPE pipe with maximum SDR of 32.5, minimum cell Class ASTM D3350, 334434C and meeting County Specifications for ductile iron pipe with restrained mechanical joints may be used for outfalls on steep slopes.
- G. PVC pipe shall require the use of bedding material for flexible pipe specified in Section 9-03 of WSDOT/APWA Standard Specifications.
- H. LCPE and SWPE shall be bedded on gravel backfill for pipe bedding as specified in Section 9-03 of WSDOT/APWA Standard Specifications. Above ground installation of SWPE does not require pipe bedding.

- I. PVC, LCPE and SWPE shall be tested using the deflection test procedure described in Section 7-17.3 of the WSDOT/APWA Standard Specifications. Unless otherwise specified the mandrel for the deflection test shall have a minimum of nine runners equally spaced, a base length equal to or less than the diameter of the pipe, and a diameter no less than 95 percent of the base inside diameter of the pipe, which is described as follows:

For pipes with controlled inside diameter, PVC and SWPE: $\text{base inside diameter} = \text{average inside pipe diameter} - ((\text{inside diameter tolerance})^2 + (\text{out of roundness tolerance})^2)^{.5}$.

For SWPE up to 30-inch the above equation simplifies to: $\text{base inside diameter} = \text{nominal diameter} \times 0.9665$.

For pipes with controlled outside diameter, LCPE: $\text{base inside diameter} = (\text{average outside diameter} - (2 \times \text{wall thickness}) - ((\text{outside diameter tolerance})^2 + (12 \text{ percent} \times \text{wall thickness})^2 + (\text{roundness tolerance})^2)^{.5}$.

Average diameter and tolerances shall be as specified by applicable ASTM standards. Pipe sections failing the mandrel test shall be replaced except that reshaping SWPE and LCPE sections to meet requirements shall be allowed if the original deformation is less than 20 percent.

- J. Concrete pipe shall be rubber gasketed and metal pipe shall be gasketed and securely banded. Leak testing shall be conducted if required by the Engineer.
- K. If the depth of a pipe exceeds eight feet or the Engineer questions the pipe selection, then the selection of pipe material must be made by a professional engineer.
- L. Bevel the projecting ends of culverts within the right-of-way.

7.04 Catch Basins and Junctions

- A. Catch basins shall be spaced no greater than 150 feet for grades less than one percent, 200 feet for grades between one and three percent; and 300 feet for grades three percent and greater. Where the width of the tributary road surface exceeds 35 feet, the cross slope exceeds four percent, or the 10-year, 24-hour rainfall exceeds three and one-half inches, catch basin spacing analysis is required. The analysis must show the depth of water at the edge of the traveled way does not exceed 0.12 feet or extend more than five feet into the traveled way for the 10-year storm event, using flows generated by the rational formula.
- B. Use catch basins, rather than inlets, to collect water from road surfaces, unless approved by the Engineer.

- C. Connections to pipe systems may be made without placing a catch basin or manhole on the mainline by meeting all of the following conditions:
1. The mainline pipe is 48 inches or greater and at least two times the size of the connecting pipe.
 2. Make connections in accordance with the manufacturer's recommendations. Standard shop fabricated tees, wyes and saddles shall be used, except for concrete pipe connections constructed in accordance with Drawing No. 2-002.
 3. There shall be a catch basin or manhole on the connecting pipe within two to ten feet of the external wall of the main line. See Drawing No. 2-002.
 4. Offset angle of connecting pipe to mainline, horizontally and vertically, shall be less than 45 degrees.
- D. Connections to an existing system shall avoid directing project runoff through downstream quality/quantity control facilities. Receiving systems may have separate conveyance facilities: one connecting to quality/quantity facilities and one by-passing them. Connection shall be to the bypass system where available.
- E. Use Type 2 catch basins where the depth to the invert of the pipe exceeds five feet.
- F. Manholes may be used in lieu of catch basins if they do not collect surface water.
- G. Roof and yard drains, or other concentrated flow from adjacent property shall not discharge over the surface of roadways or sidewalks.
- H. Catch basins or manholes are required when joining differing types of pipes.

7.05 Frames, Grates, and Covers

- A. Unless otherwise specified, use vaned grates with standard frame in the traveled way, gutter, or shoulder. Vaned grates shall not be located within cross walks.
- B. At sag vertical curves, or before intersections with a grade 4% or greater, use through curb inlet frames. Where through curb inlets cannot be used, three vaned inlets shall be used. One shall be located at the approximate low point and another on either side at 25 foot horizontal spacing, but not greater than 0.1 foot above the low point.
- C. Use rolled curb frame and (vaned) grates along rolled curbs and in asphalt turnpike shoulders. See Drawing No. 2-024.

- D. New catch basins that do not collect runoff shall use locking manhole covers. See Drawing No. 2-022. Existing catch basins which no longer collect runoff shall have their frame and grates replaced with solid covers (See Drawing No. 2-015).
- E. All storm drain covers and grates shall be locking. Manufacturer as approved by the Engineer.
- F. Slit drains may be used when approved by the Engineer. At a minimum slit drains shall have catch basins at either end unless used as a driveway culvert. The maximum distance between catch basins along a slit drain shall be 50 feet.

7.06 Erosion Control

Provide erosion control as required in the Surface Water Design Manual.

Filter fabric fences shall be constructed of material designed specifically for erosion control. The fabric shall be composed of rot-proof woven or non-woven polymeric fibers and be free of chemical treatment or coating that may reduce permeability. The fabric shall meet the following test requirements: minimum 110 lbs grab tensile strength per ASTM D-1682, minimum 40 lbs puncture strength per ASTM D-751 Modified, and 20-100 Equivalent Opening Size (EOS) based on U.S. standard sieves.

7.07 Trenches. See Section 8.03.

CHAPTER 8. UTILITIES

8.01 Franchising Policy and Permit Procedure

- A. Utilities to be located within existing and proposed County road right-of-way shall be constructed in accordance with current franchise and/or permit procedure and in compliance with these Standards. In their use of the right-of-way, utilities will be given consideration in concert with the traffic carrying requirements of the road which are, namely, to provide safe, efficient and convenient passage for motor vehicles, pedestrians, and other transportation uses. Aesthetics shall be a consideration. As a matter of policy, undergrounding of electric utilities will be strongly encouraged, particularly in urban development. Also, utilities are subject to County policies relating to drainage, erosion/sedimentation control and sensitive areas as set forth in KCC 9.04 and 21.54 and the Surface Water Design Manual.
- B. All permits for new placement and replacement of existing utility poles and other utility structures above grade shall be accompanied by written certification from a professional engineer or from an agent authorized by the utility to certify that the installations conform to these Standards and that the proposed work is in conformity with sound engineering principles relating to highway safety.
- C. Requests for exceptions to these Standards will be processed in accordance with variance procedure as referenced in Section 1.08.

8.02 Standard Utility Locations Within the Right-of-Way

Utilities within the right-of-way on new roads or on roads where existing topography, utilities or storm drains are not in conflict, shall be located as shown in typical sections, Drawings No. 1-001 through 1-006, and as indicated below. Where existing utilities or storm drains are in place, new utilities shall conform to these Standards as nearly as practicable and yet be compatible with the existing installations. Above ground utilities located within intersections shall be placed so as to avoid conflict with placement of curb ramps.

A. Gas and Water Lines:

1. **Shoulder-and-Ditch Section:**
If practical: Outside of ditch line.
Otherwise: In shoulder three feet from edge of traveled lane.
2. **Curb and Gutter Section:**
Preferable: One and one-half feet back of curb, or at distance which will clear root masses of street trees if these are present or anticipated.

Otherwise: In the street as close to the curb as practical without encroaching on the storm drainage system. Mains and service connections to all lots shall be completed prior to placing of surface materials.

3. Designated Side of Centerline:

GAS: South and West. WATER: North and East.

4. Depth: 36 inches minimum cover from finished grade, ditch bottom or natural ground.

B. Individual water service lines shall:

1. Be placed with minimum 36-inch cover from finished grade, ditch bottom or natural ground.

2. Use road right-of-way only as necessary to make side connections.

3. For any one connection, not extend more than 60 feet along or through the right-of-way, or the minimum width of the existing right-of-way.

4. Water meter boxes, when placed or re-placed, shall be located on the right-of-way line immediately adjacent to the property being served, unless otherwise approved by the Engineer. Meter box locations within the right-of-way may be approved by the Engineer based on site conditions which make routine service access difficult or impractical.

C. Sanitary Sewers: In the general case, five feet south and west of centerline; depth 36-inch minimum cover from finished grade, ditch bottom or natural ground.

D. In the case of individual sanitary sewer service lines which are force mains the pipe shall:

1. Be minimum two inches I.D., or as required by the utility to maintain internal scouring velocity.

2. If nonmetallic, contain wire or other acceptable proximity detection features; or be placed in a cast iron or other acceptable metal casing.

3. Be placed with minimum three-foot cover from finished grade, ditch bottom or natural ground, within 10 degrees of perpendicular to road centerline, and extend to right-of-way line.

4. Be jacked or bored under road unless otherwise approved by the Engineer.

E. Sanitary and water lines shall be separated in accordance with good engineering practice such as the Criteria for Sewage Work Design, Washington Department of Ecology, latest edition.

- F. Gravity systems, whether sanitary or storm drainage, shall have precedence over other systems in planning and installation except where a non-gravity system has already been installed under previous approved permit and subject to applicable provisions of such permits or franchises.
- G. Electric utilities, power, telephone, cable TV: Preferable: Underground with 36 inch minimum cover, either side of road, at plan location and depth compatible with other utilities and storm drains. Otherwise: Every new placement and every replacement of existing utility poles and other utility structures above grade shall conform to the following:
1. Utility poles or other obstacles may be placed within the right-of-way and shall be as far back from the traveled way or auxiliary lane as practicable.
 - a. On shoulder type roads, poles or obstacles shall be located back of ditches and in accordance with criteria in Drawing No. 5-001 unless protected by concrete barrier, suitable impact attenuating device or placed more than three and one-half feet behind face of guardrail, as allowed by an approved variance.
 - b. On vertical curb type roads with a speed limit less than 40 miles per hour, poles or obstacles shall be placed clear of sidewalks and at least eight and one-half feet from face of curb in business areas and five and one-half feet from curb face in residential areas. On urban roads with a speed limit of 40 miles per hour or greater, poles and obstacles shall be placed in accordance with Drawing No. 5-001.
 - c. Notwithstanding the other provisions regarding pole locations described in these standards, no pole shall be located so that it poses a hazard to the general public. Utilities shall place and replace poles with primary consideration given to public safety.
 2. The above constraints on pole and obstacle location will not apply to locations not accessible by moving vehicles, "breakaway" structures whose break-off resistance does not exceed that of 4" x 4" wood post or a 1-1/2-inch standard (hollow) iron pipe or to "breakaway" fire hydrants installed to manufacturer's specifications.
 3. Deviations from these pole and obstacle clearance criteria may be allowed by an approved variance when justified by suitable engineering study considering traffic safety. Only the Utility may request a variance from pole and obstacle clearance criteria. Up to three contiguous damaged or weakened poles may be replaced at existing locations under permit in accordance with emergency procedures, however, sequential permits resulting in continuous replacement of a pole line shall not be allowed. A pole or other obstacle which incurs repeated damage from errant vehicles shall be relocated or protected.
 4. Locations of poles shall also be compatible with driveways, intersections, and other road features (i.e., they shall not interfere with sight distances, road signing, traffic signals,

culverts, etc.). To the extent possible, utilities shall share facilities so that a minimum number of poles is needed.

5. Where road uses leave insufficient overhang, anchor, and tree-trimming space for overhead utilities, consideration will be given to variance from the Standards or to acquisition of additional easements and/or right-of-way for this purpose. Costs incurred for said acquisition shall be borne by the developer, builder, or other party initiating the road construction. However, the associated cost of relocating the utility shall not be borne by King County.

H. Notwithstanding other provisions, underground systems shall be located at least five feet away from road centerline and where they will not otherwise disturb existing survey monumentation.

8.03 Underground Utility Installation

A. General: The WSDOT/APWA Standard Specifications, particularly Section 7-17.3(3) will generally apply unless otherwise stated below.

B. Utility Cuts On Existing Traveled Roads

1. In trenching through existing pavement, the open cut shall be a neat-line cut made by either saw cutting or jackhammering a continuous line. Trench sides shall be kept as nearly vertical as possible. Compaction and restoration must be done as detailed below and immediately after the trench is backfilled, so as to cause least disruption to traffic. Cement concrete pavement shall be cut one foot outside the edge of the trench on each side.

2. In cuts parallel to road alignment:

a. All trench backfill under roadway shall be mechanically compacted to 95 percent of maximum density except for trenches over eight feet in depth. Throughout the length of any pipe run, manhole to manhole, in which any part is over eight feet deep, backfill at depths over four feet shall be compacted to 90 percent maximum density by either water settling (see Subsection 8.03C below) or mechanical compaction. The top four feet of the trench line shall then be mechanically compacted to 95 percent. All densities shall be determined by testing specified in Section 2-03.3(14)D of WSDOT/APWA Standard Specifications.

b. In any trench in which 95 percent density cannot be achieved with existing backfill, the top four feet shall be replaced with gravel base as specified in the WSDOT/APWA Standard Specifications, Section 9-03.10. This new material shall then be mechanically compacted to 95 percent.

c. Restoration of a trench within an asphalt pavement shall include a minimum of six and one-half inches of crushed surfacing material and asphalt concrete Class B the same

thickness as the existing asphalt pavement or a minimum of two inches, whichever is the greater. Pavement shall then be overlaid full width with a minimum of one inch compacted asphalt concrete Class B. Any exceptions to this overlay requirement will be on a case-by-case basis, subject to approval by the Engineer, considering the existing conditions of the pavement. Concrete pavement shall be restored consistent with Section 6-02 of the WSDOT/APWA Standard Specifications. Any concrete pavement traffic lane affected by the trenching shall have all affected panels replaced.

3. In cuts transverse to road alignment:

- a. In general, utility trenching through existing pavement across the road alignment will be discouraged. It will not be permitted unless it can be shown that alternatives such as boring or jacking are not possible due to conflicts or soil conditions, or unless the utility can be installed just prior to reconstruction or overlay of the road.
- b. Without exception, the entire trench shall be backfilled with crushed surfacing top course meeting the requirements of Section 9-03.9(3) of the WSDOT/APWA Standard Specifications. Backfill shall be placed and compacted mechanically in six inch lifts with a County inspector present. If the capability can be demonstrated, based on compaction equipment or quality of backfill to achieve 95 percent density in thicker lifts, the depth of backfill lifts may be increased up to one foot. After backfill and compaction, an immediate cold mix patch shall be placed and maintained in a manner acceptable to the Engineer. On asphalt pavement, a permanent hot mix patch the same thickness as the existing asphalt or a minimum of two inches, whichever is the greater, shall be placed and sealed with a paving grade asphalt within 30 calendar days. Cement concrete pavement shall be restored with an eight-sack mix, using either Type II or Type III cement, within 30 calendar days.

C. On Proposed Roads (e.g., New Subdivisions): Backfill compaction for trenches within the roadway of roads not open to public travel may be achieved throughout the entire depth of the trench, either by mechanical compaction as described in B.2 above, or by the following alternative method, namely, water settling:

1. Prior to electing to use the water settling method of compaction, a review of the site shall be done to determine suitability of the use of the water method and a compaction plan submitted by a professional engineer. Compaction plan is subject to approval by the Land Use Inspection Section.
2. Where water settling of trenches is done, the jetting method shall be used. In trenches over eight feet deep the Engineer may direct the backfill to be placed in two or more lifts and each be jetted separately. Jets shall be inserted at not more than four-foot intervals throughout the length of the backfilled area and shall be slowly forced, on the first lift, down to the bottom of the trench and held until the trench backfill is completely saturated with water.

Penetration shall be to the crown of the pipe, to native ground on side slopes, and subsequently to each preceding lift. The jetting operations shall be completed as soon as practicable after the pipe laying and as part of the backfilling operations.

3. After the water-settled trench has set for several days and the backfill is visibly dry, firm, and stabilized, any depression in the trench shall be filled and mounded up over the trench. It shall then be further compacted by the use of acceptable vibratory compaction equipment providing 95 percent of maximum density compaction.
4. The minimum size of hose and equipment shall be such as to provide not less than 35 pounds per square inch pressure at the discharge. The jet shall be rigid iron pipe with a minimum inside diameter of one inch.
5. Source of water will depend upon local conditions. Hydrants or surface water sources shall be utilized when such sources of water exist within 700 feet of the operations. Hauled water may be utilized when the water settling operation is more than 700 feet from a hydrant.

D. Controlled Density Backfill:

As an alternative to mechanical compaction, trench backfill above the bedding and below the base course or ATB may be accomplished by use of controlled density backfill (CDF) in a design mixture approved by the Engineer. On crossings required to be opened to traffic prior to final trench restoration, steel plates may be used as approved by the Engineer.

E. Testing:

1. Consistent with the above and prior to placing any surface materials on the roadway, it shall be the responsibility of the developer to provide density test reports certified by a professional engineer. A minimum of one test shall be taken within every 500 feet of trench length and at depths up to 50 percent of trench depth, or as directed by the Engineer. Compaction of laterals or service line trenches shall be tested where directed by the Engineer. Testing of CDF shall be in accordance with ASTM D4832.
2. Whichever compaction method the installer elects, the backfill below four feet must test to be not less than 90 percent maximum density and the upper four feet of backfill must test not less than 95 percent maximum density. Where this cannot be achieved, all affected backfill in the top four feet shall be removed and replaced by gravel base and mechanically compacted to 95 percent as in B.2 above.

F. Notification and Inspection:

1. Consistent with Section 9.02 of these Standards, any developers, utilities, or others intending to trench in existing or proposed traveled County roads shall notify King County

Land Use Inspection or Utility Inspection office not less than one working day prior to doing the work. This notification shall include:

- a. Location of the work
- b. Method of compaction to be used
- c. Day and hour when compaction is to be done
- d. Day and hour when testing is to be done.

Phones are as follows:

King County Land Use Inspection Section	296-6645 (north) and 296-6646 (south)
King County Utility Inspection Section	296-8122

2. As set forth in Section 9.03 of these Standards, failure to notify may necessitate testing or retesting by King County at the expense of the Developer or Utility. Furthermore, the work may be suspended pending satisfactory test results.

8.04 Final Utility Adjustment (To Finish Grade)

- A. All utility covers which are located on proposed asphalt roadways shall be temporarily placed at subgrade elevation prior to placing crushed surfacing material.
- B. Final adjustment of all covers and access entries shall be made following final paving by:
 1. Saw-cutting or neat-line jackhammering of the pavement around lids and covers. Opening should not be larger than 12 inches beyond the radius of the cover.
 2. Removing base material, surfacing course, and frame; adding raising bricks; replacing frame and cover no higher than finished grade of pavement and no lower than one-half inch below the pavement.
 3. Filling and mechanically compacting around the structure and frame with crushed surfacing material or ATB, or pouring in five inch minimum thickness of cement concrete Class 3000 to within two inches of the top.
 4. Filling the remaining two inches with asphalt concrete Class B hot mix, compacted and sealed to provide a dense, uniform surface.
 5. Final adjustment of all covers and access entries shall be completed within 30 days of final paving.

8.05 Final Cleanup, Restoration of Surface Drainage and Erosion Control

In addition to restoration of the road as described above, the responsible utility shall care for adjacent areas in compliance with Sections 1-04.11 "Final Cleanup" and 8-01 "Roadside Seeding" in the WSDOT/APWA Standard Specifications. In particular:

- A. Streets and roads shall be cleaned and swept both during and after the installation work.
- B. Disturbed soils shall be final graded, seeded and mulched after installation of utility. In limited areas seeding and mulching by hand, using approved methods, will be acceptable.
- C. Ditch lines with erodible soil and subject to rapid flows may require seeding, jute matting, netting, or rock lining to control erosion.
- D. Any silting of downstream drainage facilities, whether ditches or pipe and catch basins, which results from the utility installation shall be cleaned out and the work site restored to a stable condition as part of site cleanup.

CHAPTER 9. CONSTRUCTION CONTROL AND INSPECTION

9.01 Basis for Control of the Work

- A. Work performed in the construction or improvement of County roads, whether by or for a private developer, by County forces, or by County contractor, shall be done in accordance with these Standards and approved plans and specifications (Section 1.07). It is emphasized that no work may be started until such plans are approved. Any revision to such plans shall be approved by the Engineer before being implemented.
- B. The Engineer will have authority to enforce the Standards as well as other referenced or pertinent specifications. He will appoint project engineers, assistants, and inspectors as necessary to inspect the work and they will exercise such authority as the Engineer may delegate.
- C. Provisions of Section 1-05 of the WSDOT/APWA Standard Specifications shall apply, with the term "Engineer" therein construed to be the County Road Engineer as defined in Section 1.10.

9.02 Subdivision, Commercial and Right-Of-Way Land Use Inspection

On all road and drainage facility construction, proposed or in progress, which relates to subdivision, commercial and right-of-way development, control and inspection will be done by the Land Use Inspection Section, (LUIS), acting for the County Road Engineer. Unless otherwise instructed by the Engineer, construction events which require monitoring or inspection by LUIS are identified as follows, with prior notification to LUIS (telephone 296-6645 (north) and 296-6646 (south)):

- A. **Preconstruction Conference:** Three working days prior notice. Conference must precede the beginning of construction and include contractor, designing engineer, utilities, and other parties affected. Plan approvals and permits must be in hand prior to the conference.
- B. **Clearing and Temporary Erosion/Sedimentation Control:** One working day notice prior to initial site work involving drainage and installation of temporary water retention/detention and siltation control. Such work to be in accordance with Section 7.06 and the approved plans.
- C. **Utility and Storm-Drainage Installation:** One working day notice prior to trenching and placing of storm sewers and underground utilities such as sanitary, water, gas, power, telephone, and TV lines. See Section 8.03F Notification and Inspection for additional information.
- D. **Utility and Storm Drainage Backfill and Compaction:** One working day notice before backfill and compaction of storm sewers and underground utilities.
- E. **Subgrade Completion.** One working day notice at stage that underground utilities and roadway grading are complete, to include placement of gravel base if required. Inspection to include compaction tests and certifications described in Sections 8.03 and 9.04.

- F. Curb and Sidewalk Forming: One working day notice to verify proper forming and preparation prior to pouring concrete.
- G. Curb and Sidewalk Placement: One working day notice to check placement of concrete.
- H. Crushed Surfacing Placement: One working day notice to check placement and compaction of crushed surfacing base course and top course.
- I. Paving: Three working days notice in advance of paving with asphalt or portland cement concrete.
- J. Structural: Three working days notice prior to each of critical stages such as placing foundation piling or footings, placement and assembly of major components, and completion of structure and approaches. Tests and certification requirements will be as directed by the Engineer.
- K. Final Construction Inspection: 15 working days prior to overall check of road or drainage project site, to include completion of paving and associated appurtenances and improvements, cleaning of drainage system, and all necessary clean-up. Prior to approval of construction work, acceptance for maintenance and release of construction performance bonds, the developer/contractor shall pay any required fees, submit any required maintenance and defect financial guarantees, provide a certificate of monumentation and submit one photo mylar or ink-on-mylar set and sets of blue line final, corrected plans (as-built) reflecting all minor and design plan changes of the road and drainage systems. The Reviewing Agency shall specify the number of blue line sets as warranted by the type of improvement. Mylars and blue line drawings shall not have shading or adhesive addition in any areas. If original plans were completed on a CADD system, the developer/contractor shall submit, in addition to mylars, a copy of the CADD drawing files in DOS/AUTOCAD format.
- L. Final Maintenance Inspection: 30 days prior to the end of the maintenance period. Prior to release of the maintenance guarantee, there shall be successful completion of the maintenance period as described in Section 1.09, repair of any failed facilities and the payment of any outstanding fees.

9.03 Penalties for Failure to Notify for Land Use Inspection

Timely notification by the developer as noted above is essential for the County to verify through inspection that the work meets the standard. Failure to notify in time may oblige the County to arrange appropriate sampling and testing after-the-fact, with certification, either by a professional engineer or the King County Materials Engineer. Costs of such testing and certification shall be borne by the developer. At the time that such action is directed by the Engineer, the Engineer may prohibit or limit further work on the development until all directed tests have been completed and corrections made to the satisfaction of the Engineer. If necessary, the County may take further action as set forth in King County Code Title 23, Enforcement.

9.04 Embankment Construction Control in Developments

The provisions of Section 2-03 of the WSDOT/APWA Standard Specifications apply in all respects to development construction unless otherwise instructed by the Engineer. The following elements are mentioned for clarification and emphasis:

- A. Embankment and Cut Section Compaction: Compaction of the top two feet of fill subgrade and top six inches of cut subgrade shall meet a minimum 95 percent of maximum density in accordance with WSDOT/APWA Standard Specifications Section 2-03.3(14)C - Method B. Subgrade fill below the top two feet shall be compacted to 90 percent of maximum density.
- B. Testing for Density
 - 1. Prior to placing any surfacing material on the roadway, it will be the responsibility of the developer/contractor to provide density test reports reviewed and approved by a professional engineer. Optimum moisture content and maximum density shall be determined by methods cited in Section 2-03.3(14)D of WSDOT/APWA Standard Specifications or by other test procedures approved by the County Road Engineer. In fill sections, a minimum of one test shall be taken for every 1,000 cubic yards or fraction thereof and on each lift of embankment. In cut sections, the interval shall be every 100 feet of roadway. For work to be accepted tests must show consistent uniform density as required by tests referenced above.
 - 2. In cases where tests do not meet the minimum standard, corrective action shall be taken such as adding water, aerating, replacing material or applying more compactive effort as directed by the developer's engineer. Retests shall show passing densities prior to placing the next lift of subgrade fill.
 - 3. For trenching in existing roads, see Section 8.03.
- C. Finishing Subgrade

After the subgrade preparation has been completed, it shall be thoroughly checked by the developer/contractor using a level, string line, crown board, or other means to determine that the subgrade conforms to the typical section or special plan conditions prior to placing any surfacing material.

9.05 Traffic Control in Development Construction

- A. Interim Traffic Control: The developer/contractor shall be responsible for interim traffic control during construction on or along traveled County roads. When road or drainage work is to be performed on County roads that are open to traffic, the developer/contractor will be required to submit a traffic control plan for approval by the Reviewing Agency prior to beginning the work. Traffic control shall follow the guidelines of Section 1-07.23 of the WSDOT/APWA Standard Specifications. All barricades, signs and flagging shall conform to the requirements of the MUTCD

Manual. For more specific requirements for barricades, see Section 5.07 and Drawing No. 5-003. Signs must be legible and visible and should be removed at the end of each work day if not applicable after construction hours.

- B. Temporary Road Closures and Detours: When temporary road closures cannot be avoided the developer/contractor shall post "To Be Closed" signs a minimum of five days prior to the closing. The types and locations of the signs shall be shown on a detour plan. A detour plan must be prepared and submitted to the Department of Public Works, Traffic and Planning Section at least 10 working days in advance, and approved prior to closing any County road. In addition, the developer/contractor must notify, in writing, local fire, school, law enforcement authorities, Metro transit, and any other affected persons as directed by the Engineer at least five days prior to closing.
- C. Haul Routes: If the construction of a proposed development is determined by the Reviewing Agency to require special routing of large trucks or heavy construction equipment to prevent impacts to surrounding roads, residences or businesses, the developer/contractor shall be required to develop and use an approved haul route.

When required, the haul route plan must be prepared and submitted to the Reviewing Agency and approved prior to beginning or continuing construction. The haul route plan shall address routing, hours of operation, signage and flagging, and daily maintenance.

If the developer/contractor's traffic fails to use the designated haul route, the Reviewing Agency may prohibit or limit further work on the development until such time as the requirements of the haul route are complied with.

- D. Haul Road Agreement: When identified as a need by the SEPA review process or by the Engineer, a haul road agreement shall be obtained by the franchised utility, developer or property owner establishing restoration procedures to be performed upon completion of the haul operation.

9.06 County Forces and County Contract Road Inspection

Road construction performed by County forces or by contract for the County will be inspected under the supervision of the Engineer.

9.07 Call Before You Dig

Builders are responsible for timely notification of utilities in advance of any construction in right-of-way or utility easements. The utility One-Call Center phone number 1-800-424-5555 should be prominently displayed on the work site.

DRAWINGS

THIS PAGE INTENTIONALLY LEFT BLANK

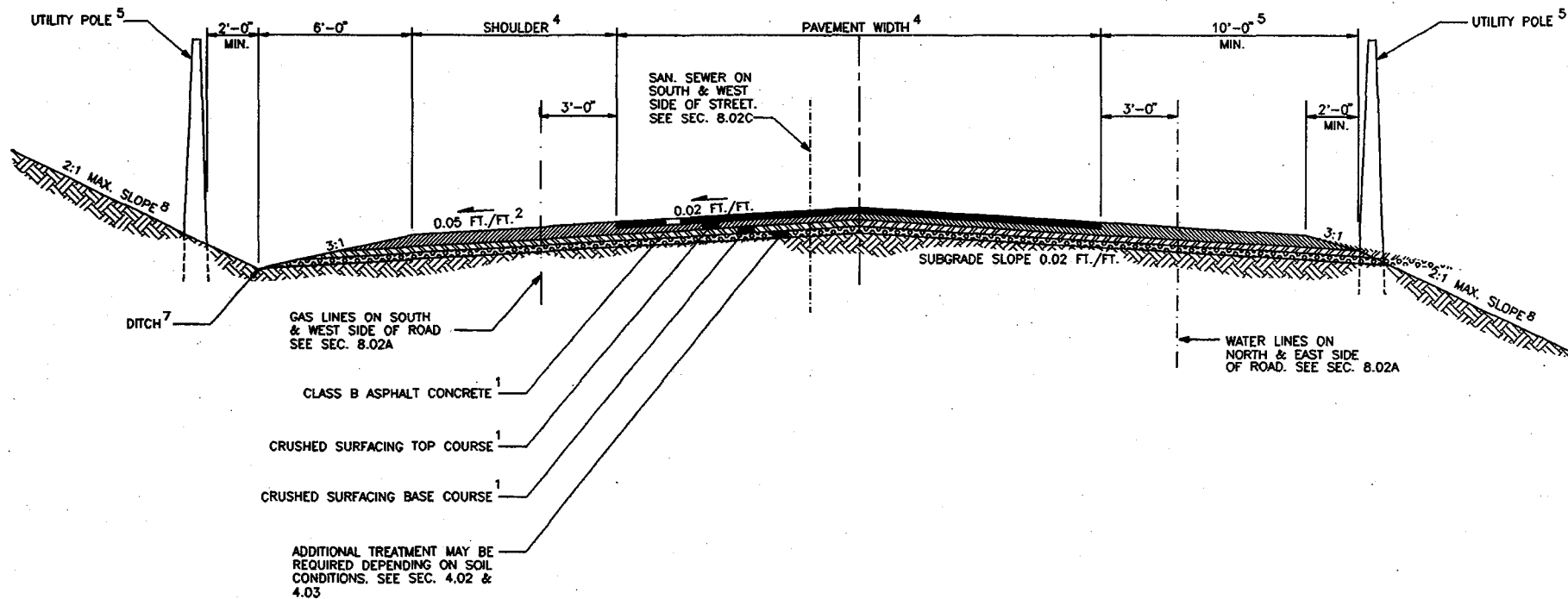

NOTES:

1. THIS DRAWING ILLUSTRATES A TYPICAL ASPHALT CONCRETE ROAD SECTION, ALTERNATIVE II WITH GRAVEL SHOULDERS. ACTUAL SURFACING DESIGN FOR ARTERIALS AND COMMERCIAL ACCESS STREETS SHALL BE BASED ON SOILS AND TRAFFIC ANALYSIS PER SEC. 4.03. DESIGN FOR RESIDENTIAL ACCESS STREETS SHALL BE IN ACCORDANCE WITH SECS. 4.01 AND 4.02.
2. SHOULDERS SHALL BE SURFACED AS REQUIRED BY SECS. 3.07 AND 4.01. IF PAVED, SHOULDER SLOPE SHALL MATCH CROWN SLOPE OR 0.02 FT./FT.
3. GRADES:
 MINIMUM 0.5%
 MAXIMUM SEE SECS. 2.02, 2.03, 2.04, AND 2.11.
4. FOR WIDTHS OF PAVEMENT, SHOULDER, AND RIGHT-OF-WAY, SEE SECS. 2.02, 2.03, 2.04.
5. FOR CLEARANCE OF UTILITY POLES SEE SEC. 8.02G AND DWG. NO. 5-001.
6. SEE SEC. 3.08 FOR SEPARATED WALKWAY IF REQUIRED.
7. DITCH SECTIONS AND/OR LOCATIONS MAY VARY TO MEET REQUIREMENTS OF THE SURFACE WATER DESIGN MANUAL. FOR RURAL NEIGHBORHOOD COLLECTORS SEE DWG. NO. 2-024 FOR TURNPIKE SHOULDER ALTERNATIVE.
8. SEE SEC. 5.02 FOR SIDE SLOPE REQUIREMENTS.



KING COUNTY PUBLIC WORKS
 KING COUNTY, WASHINGTON

SHOULDER TYPE ROADWAY

DWG. 1-001
 NO.

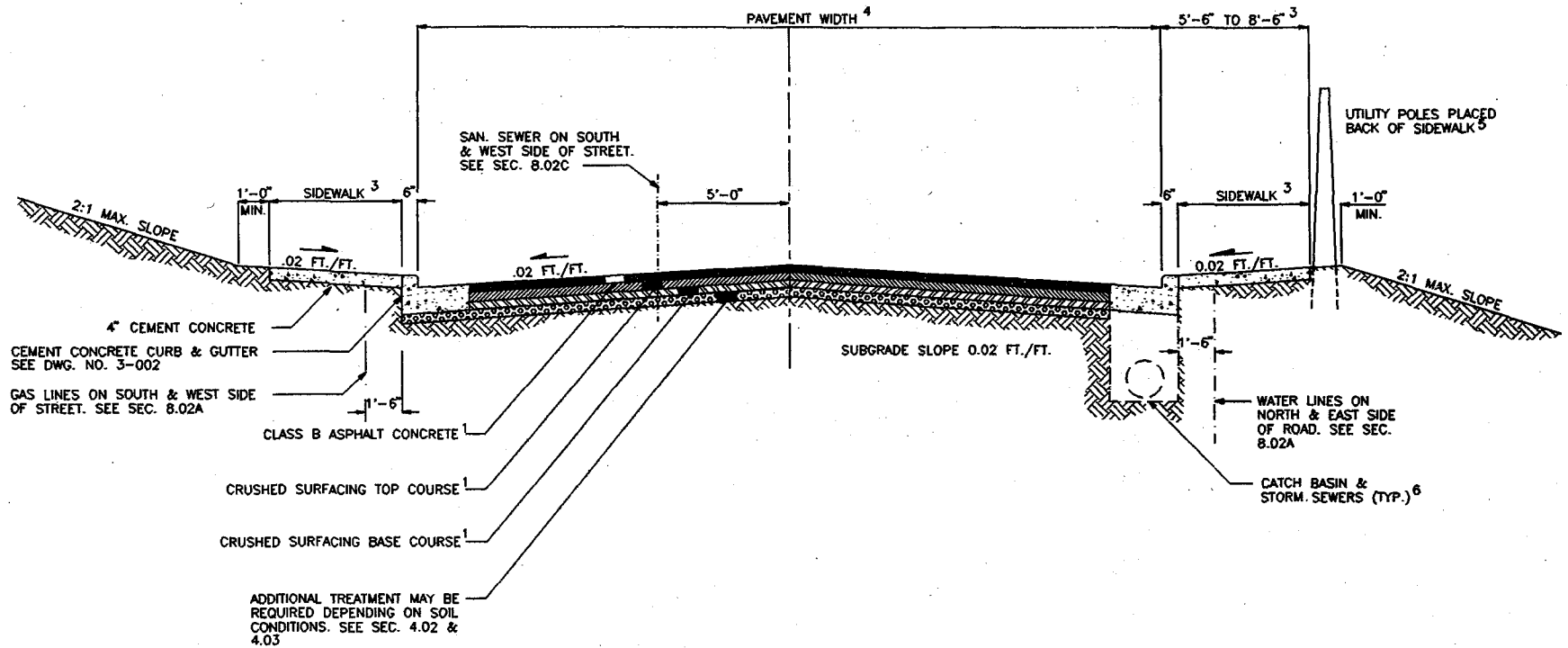

NOTES:

- THIS DRAWING ILLUSTRATES A TYPICAL ASPHALT CONCRETE ROAD SECTION, ALTERNATIVE II. ACTUAL SURFACING DESIGN FOR ARTERIALS AND COMMERCIAL ACCESS STREETS SHALL BE BASED ON SOILS AND TRAFFIC ANALYSIS PER SEC. 4.03. DESIGN FOR RESIDENTIAL ACCESS SHALL BE IN ACCORDANCE WITH SECS. 4.01 AND 4.02.
- GRADES:
 MINIMUM 0.5%
 MAXIMUM SEE SECS. 2.02, 2.03, 2.04, AND 2.11.
- SIDEWALKS SHALL BE 8 FT. WIDE IN BUSINESS DISTRICTS AND 6.5 FT. WIDE ON ARTERIALS IF NEXT TO TRAFFIC LANE, 5 FT. WIDE IF NEXT TO PARKING OR BIKE LANE, OR BEHIND PLANTING STRIP SEE SECTION 3.02B.
- FOR WIDTHS OF PAVEMENT, SHOULDER, AND RIGHT-OF-WAY, SEE SECS. 2.02, 2.03, AND 2.04.
- FOR CLEARANCE OF UTILITY POLES SEE SEC. 8.02G AND DWG. NO. 5-001.
- SEE CHAPTER 7 FOR CATCH BASIN AND STORM SEWER LOCATIONS.
- SEE SEC. 5.02 FOR SIDE SLOPE REQUIREMENTS.

DATE	REVISION	BY	APPR'D



KING COUNTY PUBLIC WORKS
KING COUNTY, WASHINGTON

VERTICAL CURB TYPE ROADWAY

DWG. NO. 1-002

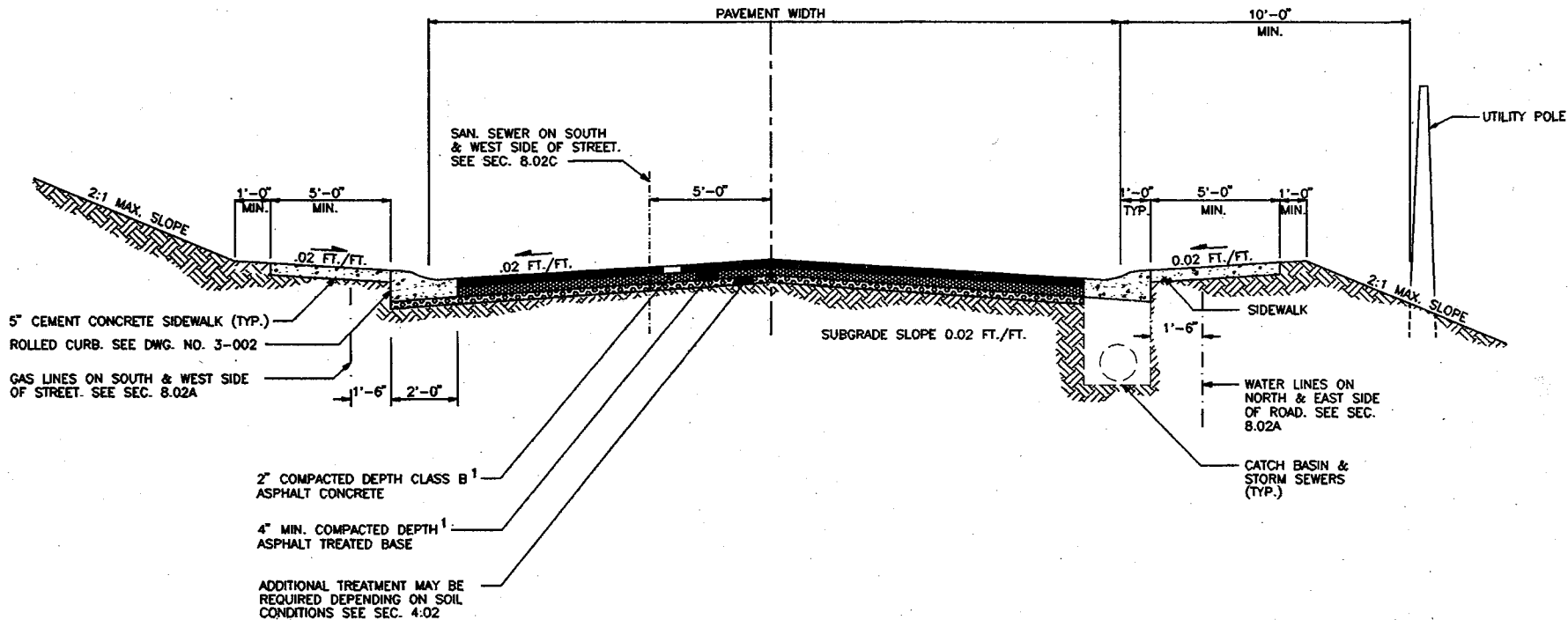

NOTES:

1. THIS DRAWING ILLUSTRATES A TYPICAL ASPHALT CONCRETE ROAD SECTION, ALTERNATIVE I. FOR OTHER ALTERNATIVES AND POSSIBLE REQUIREMENTS FOR FRACTURED AGGREGATE OR INCREASED THICKNESS OF SURFACING MATERIALS, SEE SECS. 4.01 AND 4.02.
2. GRADES:
 MINIMUM 0.5%
 MAXIMUM SEE SECS. 2.03 AND 2.11.
3. SEE CHAPTER 7 FOR CATCH BASIN AND STORM SEWER LOCATIONS. SEE DWG. NO.S 2-019, 2-020, AND 2-021 FOR GRATE DETAILS.
4. FOR WIDTHS OF PAVEMENT AND RIGHT-OF-WAY, SEE SECS. 2.03.
5. FOR CLEARANCE OF UTILITY POLES SEE SEC. 8.02G AND DWG. NO. 5-001.
6. SEE SEC. 5.02 FOR SIDE SLOPE REQUIREMENTS.

DATE	REVISION	BY	APPR'D



KING COUNTY PUBLIC WORKS
KING COUNTY, WASHINGTON

ROLLED CURB TYPE ROADWAY

DWG. NO. 1-003

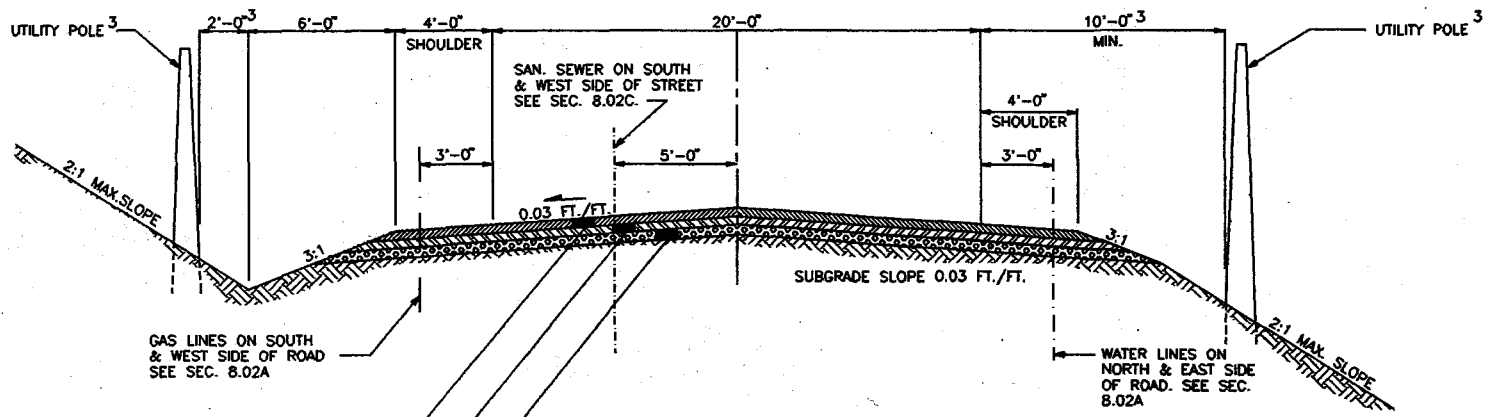

1 1/2" COMPACTED DEPTH CRUSHED SURFACING TOP COURSE INCLUDING SHOULDERS

2 1/2" MIN. COMPACTED CRUSHED SURFACING BASE COURSE

ADDITIONAL TREATMENT MAY BE REQUIRED DEPENDING ON SOIL CONDITIONS. SEE SEC. 4.01 & 4.02

NOTES:

- GRAVEL SURFACING IS ACCEPTABLE ONLY ON RURAL MINOR ACCESS STREETS (RESIDENTIAL) WHICH ARE PRIVATE STREETS. SEE SECS. 2.03 & 2.17.
- GRADES:
MINIMUM 0.5%
MAXIMUM SEE SECS. 2.03 & 2.11.
- FOR CLEARANCE OF UTILITY POLES SEE SEC. 8.02G & DWG. NO. 5-001.
- DITCH SECTIONS AND/OR LOCATIONS MAY VARY TO MEET REQUIREMENTS OF SURFACE WATER DESIGN MANUAL.
- SEE SEC. 5.02 FOR SIDE SLOPE REQUIREMENTS.

DATE	REVISION	BY	APPR'D



KING COUNTY PUBLIC WORKS
KING COUNTY, WASHINGTON

GRAVEL SURFACE ROADWAY

DWG. NO. 1-004

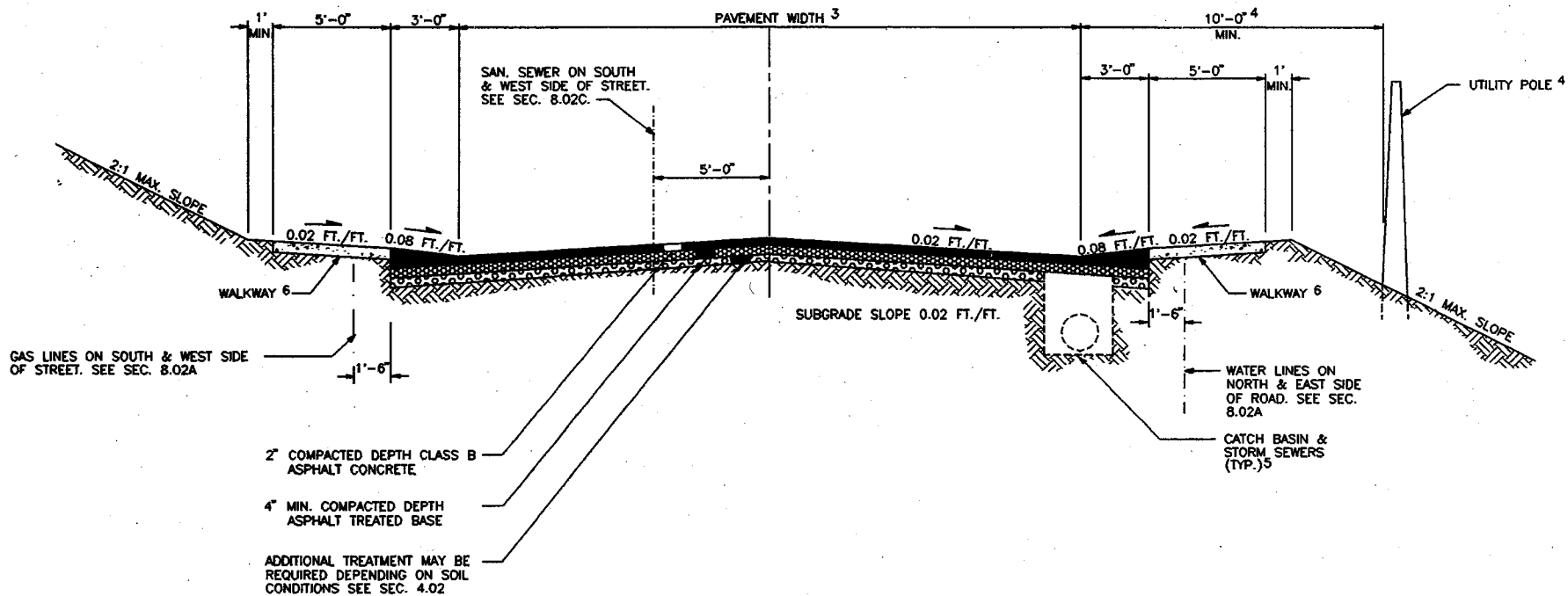

NOTES:

1. THIS DRAWING ILLUSTRATES A TYPICAL ASPHALT CONCRETE ROAD SECTION, ALTERNATIVE I. FOR OTHER ALTERNATIVES AND POSSIBLE REQUIREMENTS FOR FRACTURED AGGREGATE OR INCREASED THICKNESS OF SURFACING MATERIALS, SEE SECS. 4.01 AND 4.02.
2. GRADES:

MINIMUM	0.5%
MAXIMUM	SEE SECS. 2.03 AND 2.11.
3. FOR WIDTHS OF PAVEMENT AND RIGHT-OF-WAY, SEE SECS. 2.03.
4. FOR CLEARANCE OF UTILITY POLES SEE SEC. 8.02G AND DWG. NO. 5-001.
5. SEE CHAPTER 7 FOR CATCH BASINS AND STORM SEWER LOCATIONS.
6. WALKWAY SHALL BE CEMENT CONCRETE, ALTERNATIVE IV, OR CRUSHED SURFACING, ALTERNATIVE V, AS REQUIRED BY REVIEWING AGENCY. SEE SEC. 4.01.
7. FOR RURAL NEIGHBORHOOD COLLECTORS, SEE DWG. NO. 2-024 FOR TURNPIKE SHOULDER ALTERNATIVE.
8. SEE SEC. 5.02 FOR SIDE SLOPE REQUIREMENTS.



KING COUNTY PUBLIC WORKS
KING COUNTY, WASHINGTON

THICKENED EDGE ROADWAY

DWG. 1-005
NO.

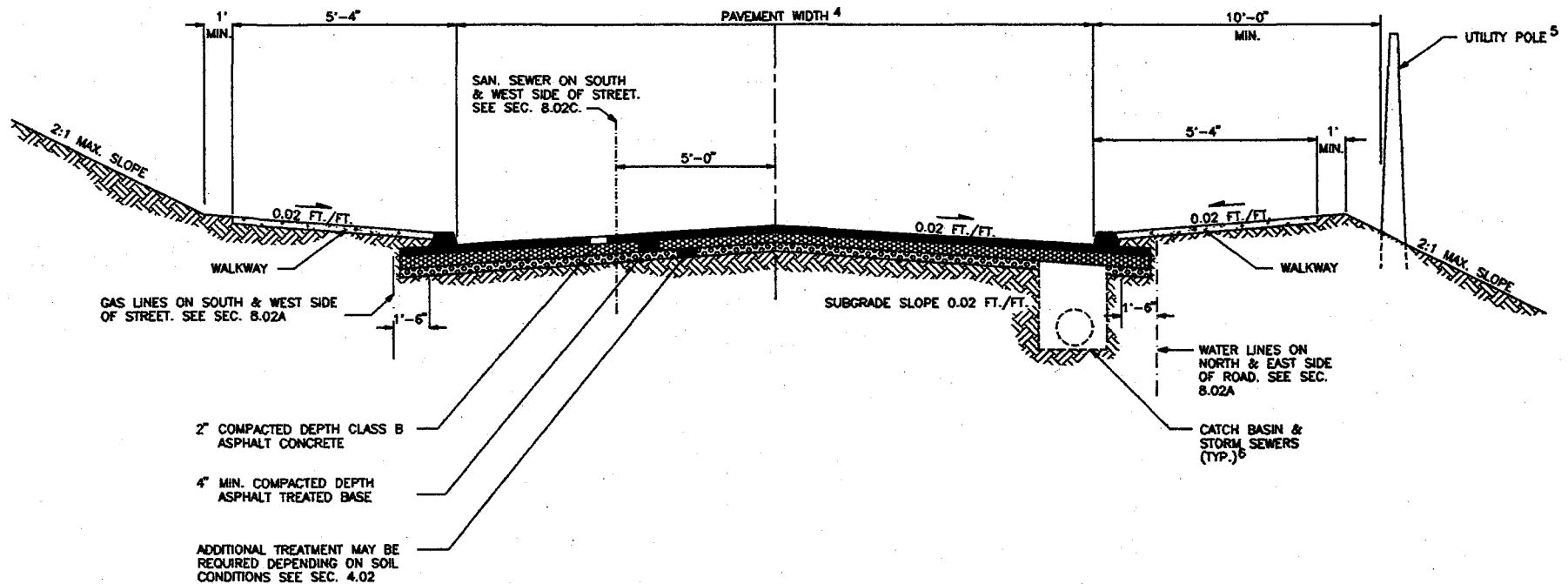

NOTES:

1. THIS DRAWING ILLUSTRATES A TYPICAL ASPHALT CONCRETE ROAD SECTION, ALTERNATIVE I. FOR OTHER ALTERNATIVES AND POSSIBLE REQUIREMENTS FOR FRACTURED AGGREGATE OR INCREASED THICKNESS OF SURFACING MATERIALS. SEE SECS. 4.01 AND 4.02.
2. FOR EXTRUDED CURB DETAIL SEE DWG. NO. 3-002.
3. GRADES:
MINIMUM 0.5%
MAXIMUM SEE SECS. 2.03 AND 2.09.
4. FOR WIDTHS OF PAVEMENT AND RIGHT-OF-WAY, SEE SECS. 2.03.
5. FOR CLEARANCE OF UTILITY POLES SEE SEC. 8.02G AND DWG. NO. 5-001.
6. SEE CHAPTER 7 FOR CATCH BASIN AND STORM DRAIN LOCATIONS.
7. WALKWAY SHALL BE CRUSHED SURFACING, ALTERNATIVE V, OR AS REQUIRED BY REVIEWING AGENCY.
8. SEE SEC 5.02 FOR SIDE SLOPE REQUIREMENTS.

DATE	REVISION	BY	APPR'D



KING COUNTY PUBLIC WORKS
KING COUNTY, WASHINGTON

EXTRUDED CURB ROADWAY

DWG. 1-006
NO.

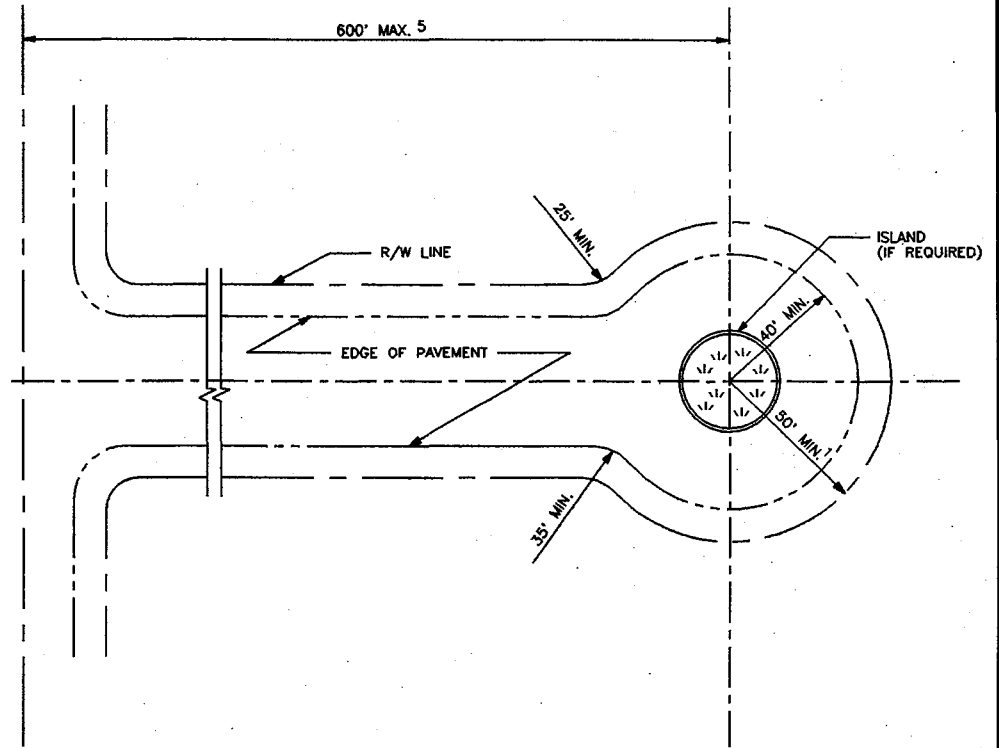
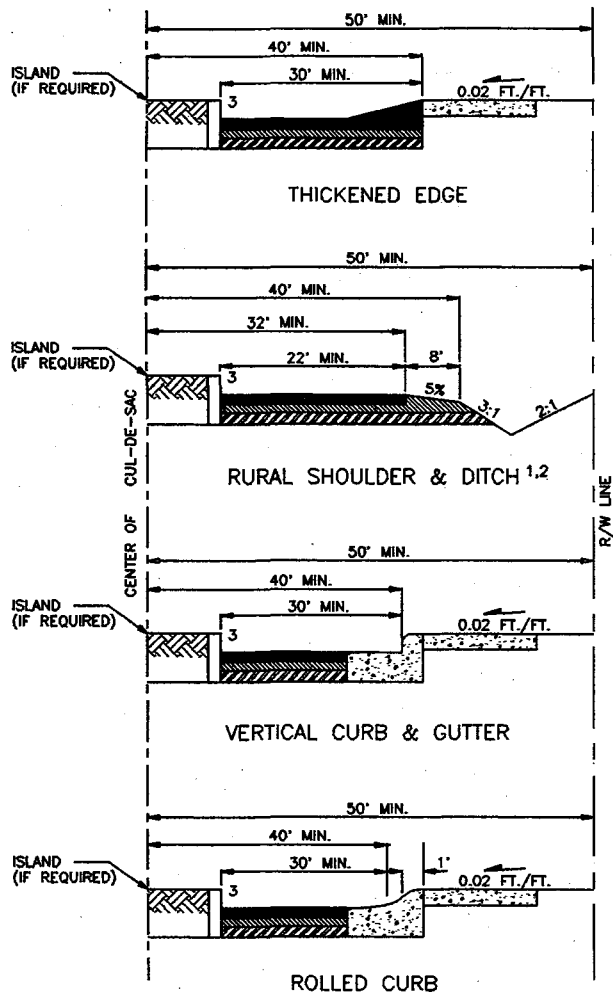

NOTES:

1. SEE SEC. 2.08.
2. EXTRUDED CURB IS ALSO ACCEPTABLE FOR OUTER EDGE AS ALTERNATIVE TO SHOULDER AND DITCH. SEE DWG. NO. 1-006.
3. ISLAND AT CENTER OF BULB SHALL HAVE VERTICAL CURB. SEE DWG. NO. 3-002.
4. ISLAND IS MANDATORY WHEN RADIUS OF PAVED AREA EXCEEDS 40'.
5. SEE SEC 2.08 FOR CUL-DE-SAC LENGTH EXCEPTION.
6. SEE SECS. 2.03, 2.08, AND 2.09 FOR RIGHT-OF-WAY REDUCTION REQUIREMENTS



KING COUNTY PUBLIC WORKS
KING COUNTY, WASHINGTON

CUL-DE-SACS

DWG. 1-007
NO.

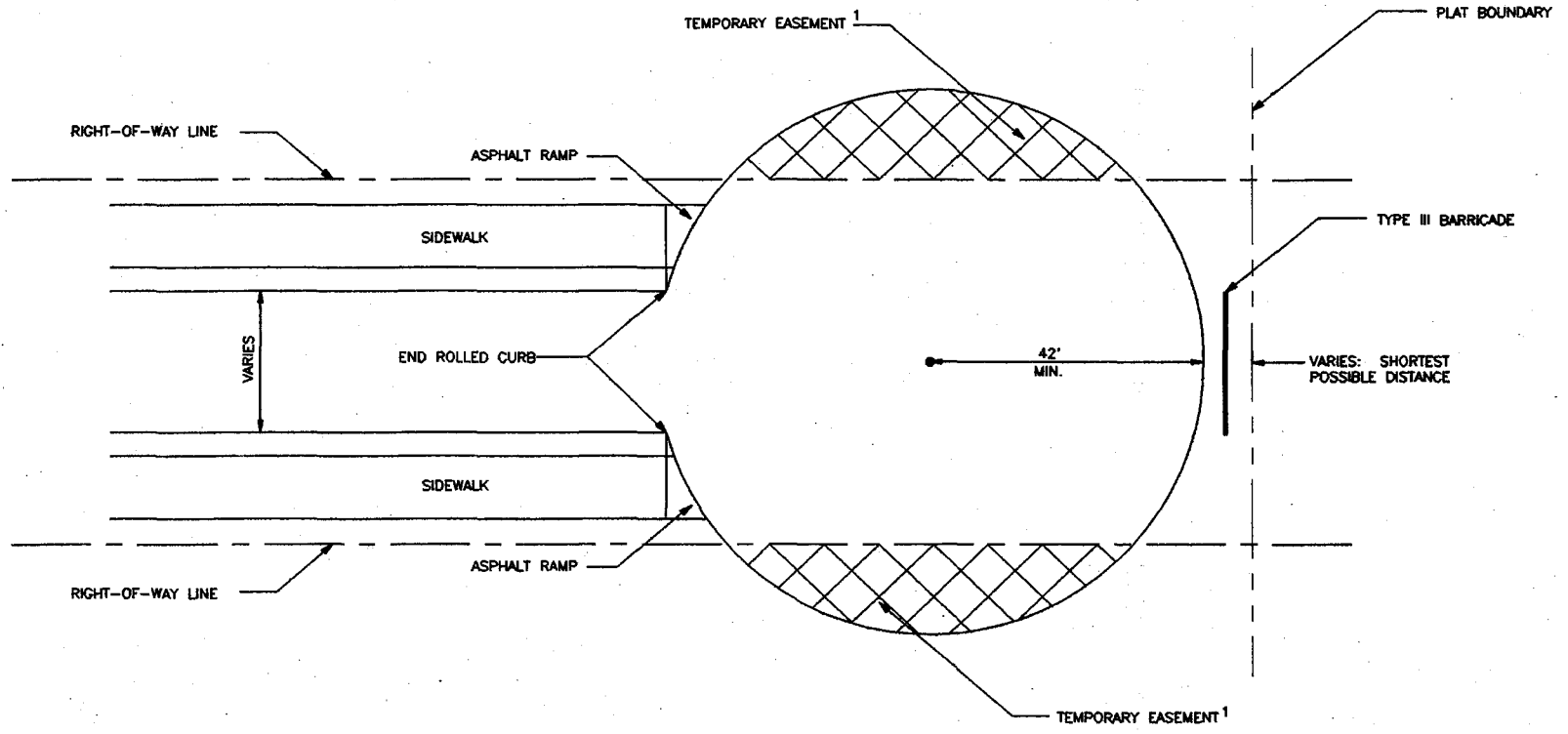

NOTES:

1. SEE SEC. 2.08.
2. BARRICADE REQUIRED AT END OF BULB.
SEE SEC. 5.07.

DATE	REVISION	BY	APPR'D



KING COUNTY PUBLIC WORKS
KING COUNTY, WASHINGTON

TEMPORARY CUL-DE-SAC

DWG. NO. 1-008

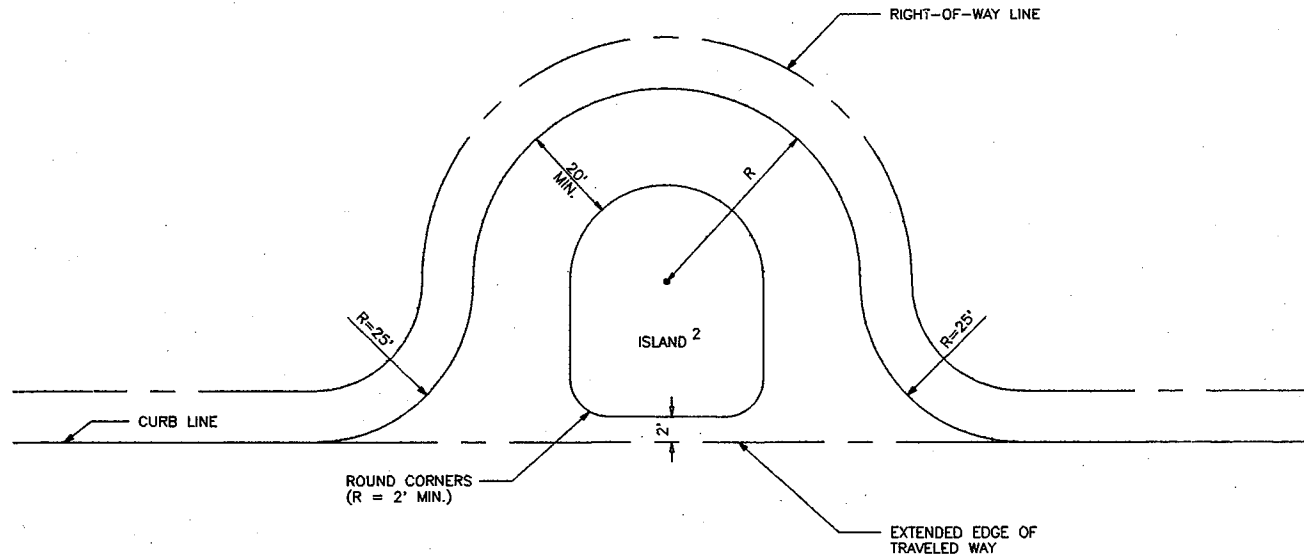

NOTES:

1. SEE SEC. 2.08F.
2. ISLAND REQUIRED ON EYEBROWS WITH R GREATER THAN 25 FEET.
3. MIN. ISLAND DIAM. SHALL BE 10 FEET.

DATE	REVISION	BY	APPR'D



KING COUNTY PUBLIC WORKS
KING COUNTY, WASHINGTON

EYEBROW

DWG. NO. 1-009

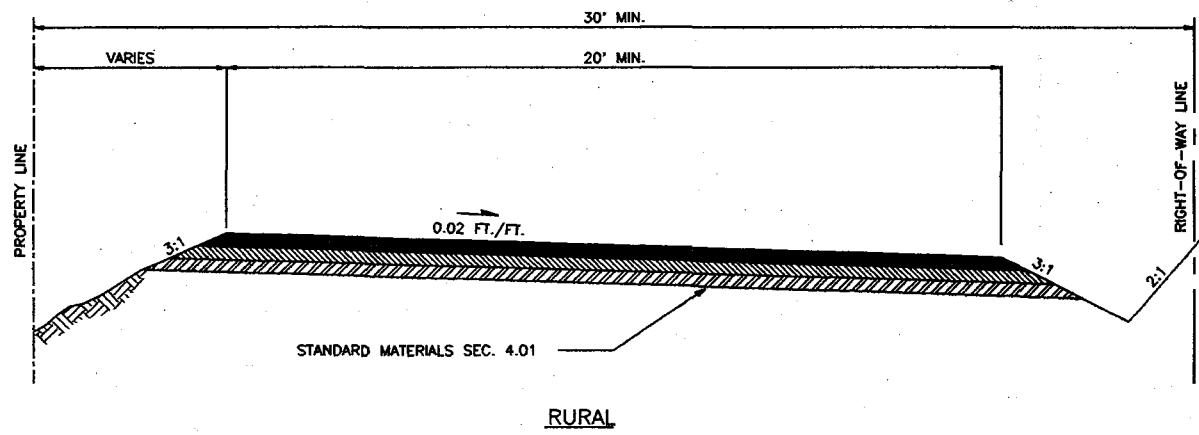
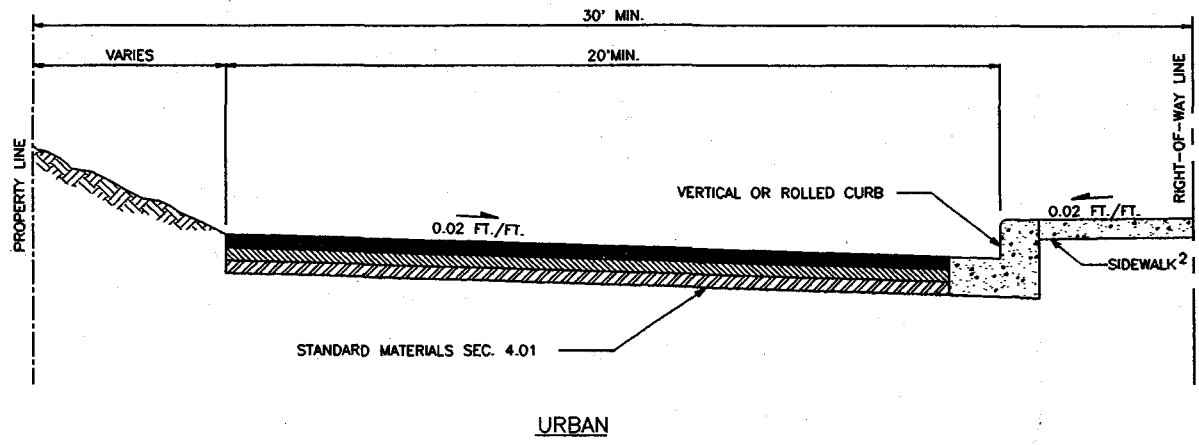

NOTE:

1. SEE SEC. 2.07.
2. SEE SEC. 3.02.
3. EDGE OF PAVEMENT TO BE CONSTRUCTED AS SHOWN FOR CUT OR FILL SECTION AS APPROPRIATE.



KING COUNTY PUBLIC WORKS
KING COUNTY, WASHINGTON

HALF-STREET

DWG. NO. 1-010

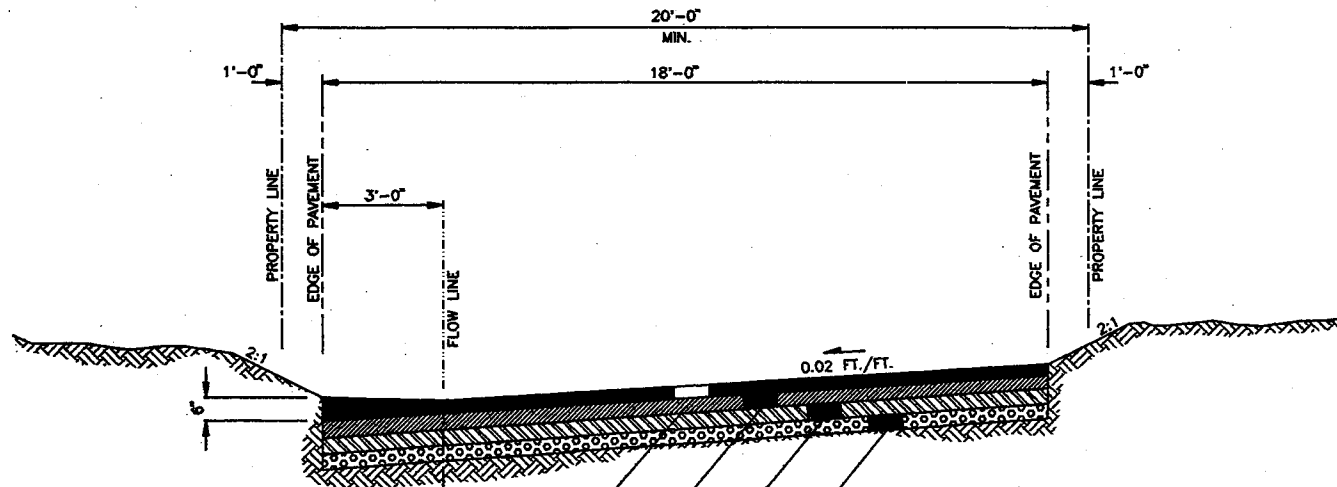

- 2" COMPACTED DEPTH CLASS B ASPHALT CONCRETE
- 1 1/2" MIN. COMPACTED DEPTH CRUSHED SURFACING TOP COURSE
- 2 1/2" MIN. COMPACTED DEPTH CRUSHED SURFACING BASE COURSE
- ADDITIONAL TREATMENT MAY BE REQUIRED DEPENDING ON SOIL CONDITIONS. SEE SEC. 4.02

NOTE:
SEE SEC. 2.09

DATE	REVISION	BY	APPR'D



KING COUNTY PUBLIC WORKS
KING COUNTY, WASHINGTON

ALLEY PAVEMENT DETAIL

DWG. NO. 1-011

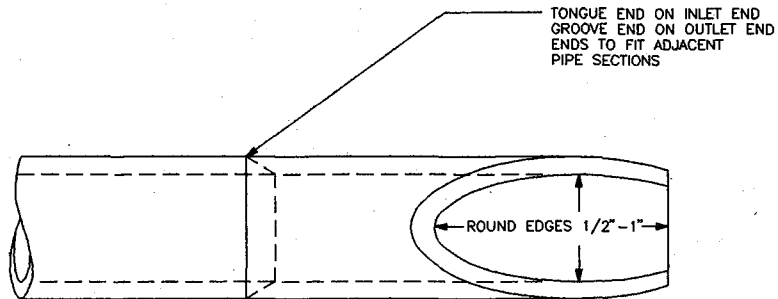

PLAN

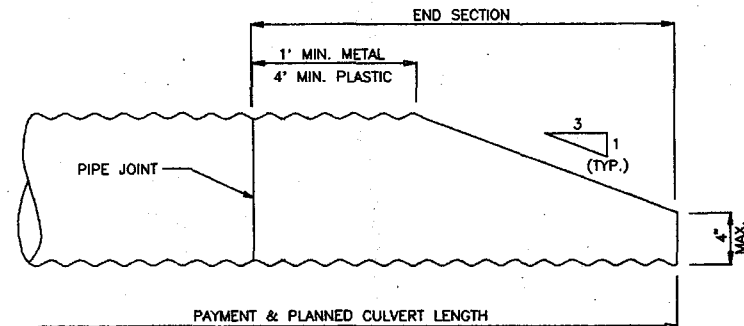

METAL & PLASTIC PIPE

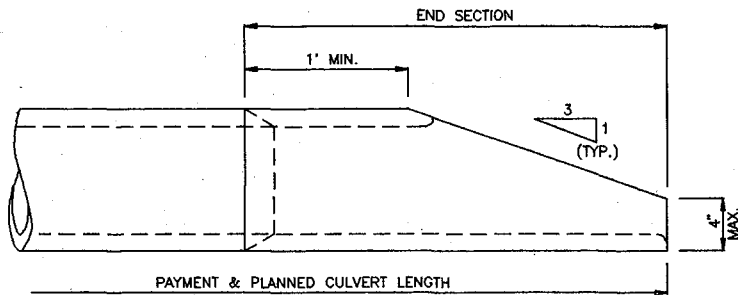

ELEVATION

CONCRETE PIPE

NOTE:

SIDE SLOPE SHALL BE WARPED TO MATCH THE BEVELED PIPE END. WHEN CULVERT IS ON SKEW, BEVELED END SHALL BE ROTATED TO CONFORM TO SLOPE. IF SLOPE DIFFERS FROM 3:1, PIPE SHALL BE BEVELED TO MATCH SLOPE.

DATE	REVISION	BY	APPR'D



KING COUNTY PUBLIC WORKS
KING COUNTY, WASHINGTON

BEVELED END PIPE SECTION

DWG. NO. 2-001

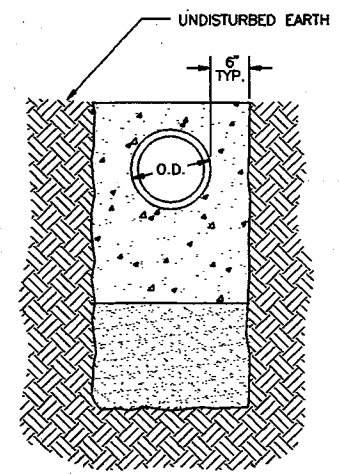
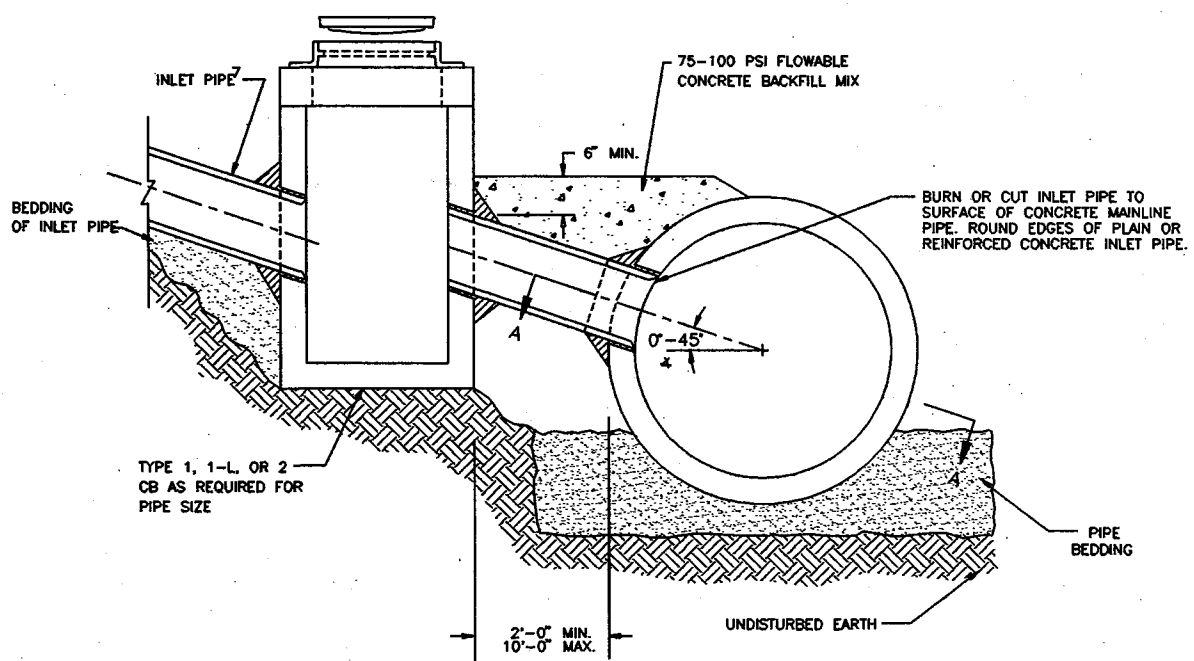

SECTION B-B

NOTES:

1. "D", THE INSIDE DIAM. OF THE INLET PIPE, SHALL BE 24" OR LESS. FOR LARGER VALUES OF "D", USE AN APPROVED STRUCTURE.
2. IN NO CASE SHALL THE OUTSIDE DIAM. OF THE INLET PIPE EXCEED ONE-HALF THE INSIDE DIAM. OF THE MAIN STORM SEWER.
3. C OF INLET PIPE SHALL BE ON RADIUS OF MAIN STORM DRAIN.
4. THE MIN. OPENING INTO THE EXISTING STORM DRAIN SHALL BE THE OUTSIDE DIAM. OF THE INLET PIPE PLUS 1 IN.
5. IF α IS GREATER THAN 45° FIELD TAPPING IS NOT ALLOWED.
6. SEE SEC. 7.04.
7. SEE SEC. 7.03 FOR ALLOWED INLET PIPE TYPE.
8. MAINLINE SHALL HAVE 48" MIN. DIAM.

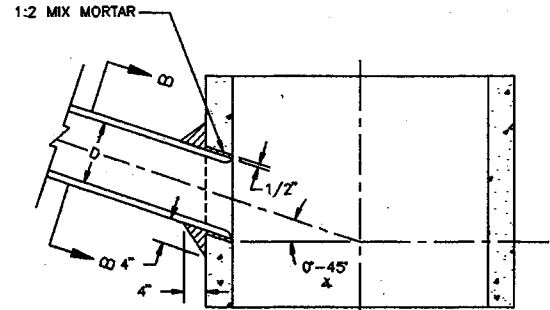

SECTION A-A

DATE	REVISION	BY	APPR'D



KING COUNTY PUBLIC WORKS
KING COUNTY, WASHINGTON

FIELD-TAPPING OF CONCRETE PIPE

DWG. NO. 2-002

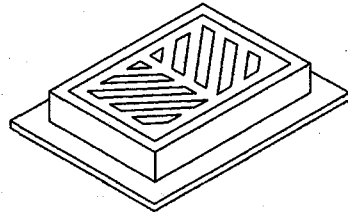

FRAME AND GRATE
SEE SEC. 7.05 AND
APPLICABLE DWGS.

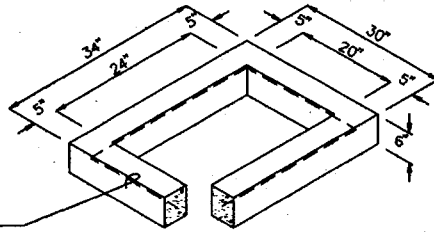

6" RISER SECTION

1 #3 BAR HOOP

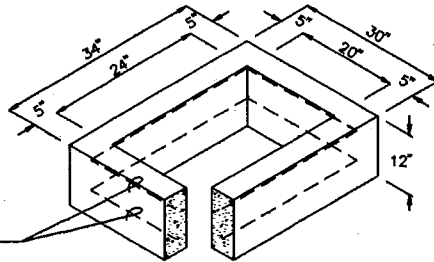

12" RISER SECTION

2 #3 BAR HOOPS

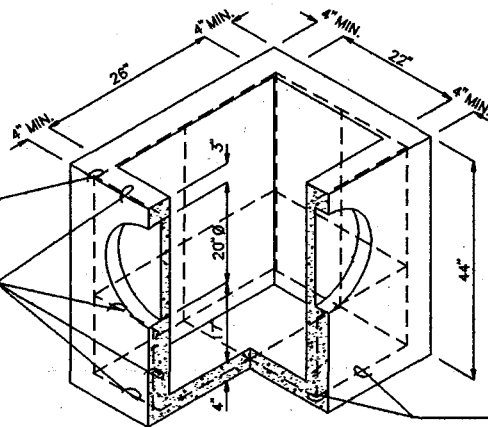

PRECAST BASE SECTION
(MEASUREMENT AT THE TOP
OF THE BASE)

#3 BAR EACH CORNER

#3 BAR EACH SIDE

#3 BAR EACH WAY

NOTES:

1. CATCH BASINS SHALL BE CONSTRUCTED IN ACCORDANCE WITH ASTM C478 (AASHTO M 199) & C890 UNLESS OTHERWISE SHOWN ON PLANS OR NOTED IN THE WSDOT/APWA STANDARD SPECIFICATIONS.
2. AS AN ACCEPTABLE ALTERNATIVE TO REBAR, WELDED WIRE FABRIC HAVING A MIN. AREA OF 0.12 SQUARE INCHES PER FOOT MAY BE USED. WELDED WIRE FABRIC SHALL COMPLY TO ASTM A497 (AASHTO M 221). WIRE FABRIC SHALL NOT BE PLACED IN KNOCKOUTS.
3. ALL REINFORCED CAST-IN-PLACE CONCRETE SHALL BE CLASS 4000.
4. PRECAST BASES SHALL BE FURNISHED WITH CUTOUTS OR KNOCKOUTS. KNOCKOUTS SHALL HAVE A WALL THICKNESS OF 2" MIN. ALL PIPE SHALL BE INSTALLED IN FACTORY PROVIDED KNOCKOUTS. UNUSED KNOCKOUTS NEED NOT BE GROUTED IF WALL IS LEFT INTACT.
5. KNOCKOUT OR CUTOUT HOLE SIZE IS EQUAL TO PIPE OUTER DIAM. PLUS CATCH BASIN WALL THICKNESS.
6. ROUND KNOCKOUTS MAY BE ON ALL 4 SIDES, WITH MAX. DIAM. OF 20". KNOCKOUTS MAY BE EITHER ROUND OR "D" SHAPE.
7. THE MAX. DEPTH FROM THE FINISHED GRADE TO THE PIPE INVERT IS 5'-0".
8. THE TAPER ON THE SIDES OF THE PRECAST BASE SECTION AND RISER SECTION SHALL NOT EXCEED 1/2"/FT.
9. CATCH BASIN FRAME AND GRATE SHALL BE IN ACCORDANCE WITH STANDARD SPECIFICATIONS AND MEET THE STRENGTH REQUIREMENTS OF FEDERAL SPECIFICATION RR-F-62ID. MATING SURFACES SHALL BE FINISHED TO ASSURE NON-ROCKING FIT WITH ANY COVER POSITION.
10. FRAME AND GRATE MAY BE INSTALLED WITH FLANGE DOWN OR CAST INTO RISER.
11. FOR CATCH BASINS IN PARKING LOTS REFER TO WSDOT/APWA STANDARD DWG. B1-b.
12. EDGE OF RISER OR BRICK SHALL NOT BE MORE THAN 2" FROM VERTICAL EDGE OF CATCH BASIN WALL.

DATE	REVISION	BY	APPR'D



KING COUNTY PUBLIC WORKS
KING COUNTY, WASHINGTON

CATCH BASIN TYPE 1

DWG. 2-003
NO.

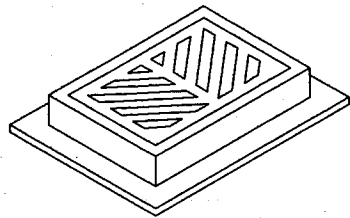

FRAME AND GRATE.
SEE SEC. 7.05 AND
APPLICABLE DWGS.

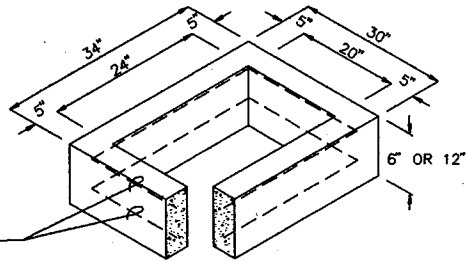

RISER SECTION

1 #3 BAR HOOP FOR 6"
2 #3 BAR HOOP FOR 12"

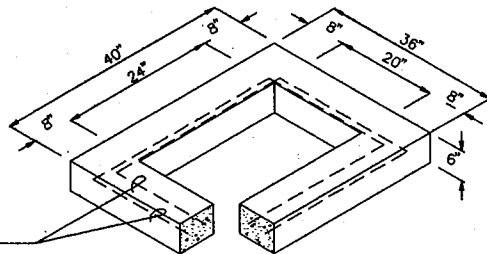

6" REDUCING SECTION

2 #3 BAR HOOP

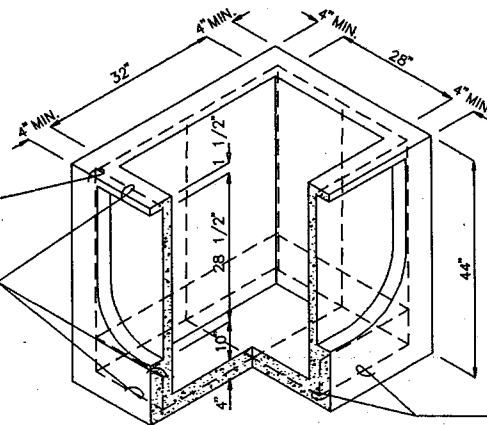

PRECAST BASE SECTION
(MEASUREMENT AT THE TOP
OF THE BASE)

#3 BAR EACH CORNER

#3 BAR EACH SIDE

#3 BAR EACH WAY

NOTES:

1. CATCH BASINS SHALL BE CONSTRUCTED IN ACCORDANCE WITH ASTM C478 (AASHTO M 199) & C890 UNLESS OTHERWISE SHOWN ON PLANS OR NOTED IN THE WSDOT/APWA STANDARD SPECIFICATIONS.
2. AS AN ACCEPTABLE ALTERNATIVE TO REBAR, WELDED WIRE FABRIC HAVING A MIN. AREA OF 0.12 SQUARE INCHES PER FOOT MAY BE USED. WELDED WIRE FABRIC SHALL COMPLY TO ASTM A497 (AASHTO M 221). WIRE FABRIC SHALL NOT BE PLACED IN KNOCKOUTS.
3. ALL REINFORCED CAST-IN-PLACE CONCRETE SHALL BE CLASS 4000.
4. PRECAST BASES SHALL BE FURNISHED WITH CUTOUTS OR KNOCKOUTS. KNOCKOUTS SHALL HAVE A WALL THICKNESS OF 2" MIN. ALL PIPE SHALL BE INSTALLED IN FACTORY PROVIDED KNOCKOUTS. UNUSED KNOCKOUTS NEED NOT BE GROUTED IF WALL IS LEFT INTACT.
5. KNOCKOUT OR CUTOUT HOLE SIZE IS EQUAL TO PIPE OUTER DIAM. PLUS CATCH BASIN WALL THICKNESS.
6. KNOCKOUTS MAY BE ON ALL 4 SIDES WITH MAX. DIAM. OF 28". KNOCKOUTS MAY BE EITHER ROUND OR "D" SHAPE.
7. THE TAPER ON THE SIDES OF THE PRECAST BASE SECTION AND RISER SECTION SHALL NOT EXCEED 1/2"/FT.
8. CATCH BASIN FRAME AND GRATE SHALL BE IN ACCORDANCE WITH STANDARD SPECIFICATIONS AND MEET THE STRENGTH REQUIREMENTS OF FEDERAL SPECIFICATION RR-F-621D. MATING SURFACES SHALL BE FINISHED TO ASSURE NON-ROCKING FIT WITH ANY COVER POSITION.
9. FRAME AND GRATE MAY BE INSTALLED WITH FLANGE DOWN OR CAST INTO RISER.
10. MAX. DEPTH FROM FINISHED GRADE TO PIPE INVERT SHALL BE 5'-0".
11. EDGE OF REDUCING SECTION OR BRICK SHALL NOT BE MORE THAN 2" FROM VERTICAL EDGE OF CATCH BASIN WALL.

DATE	REVISION	BY	APPR'D



KING COUNTY PUBLIC WORKS
KING COUNTY, WASHINGTON

CATCH BASIN TYPE 1-L

DWG. NO. 2-004

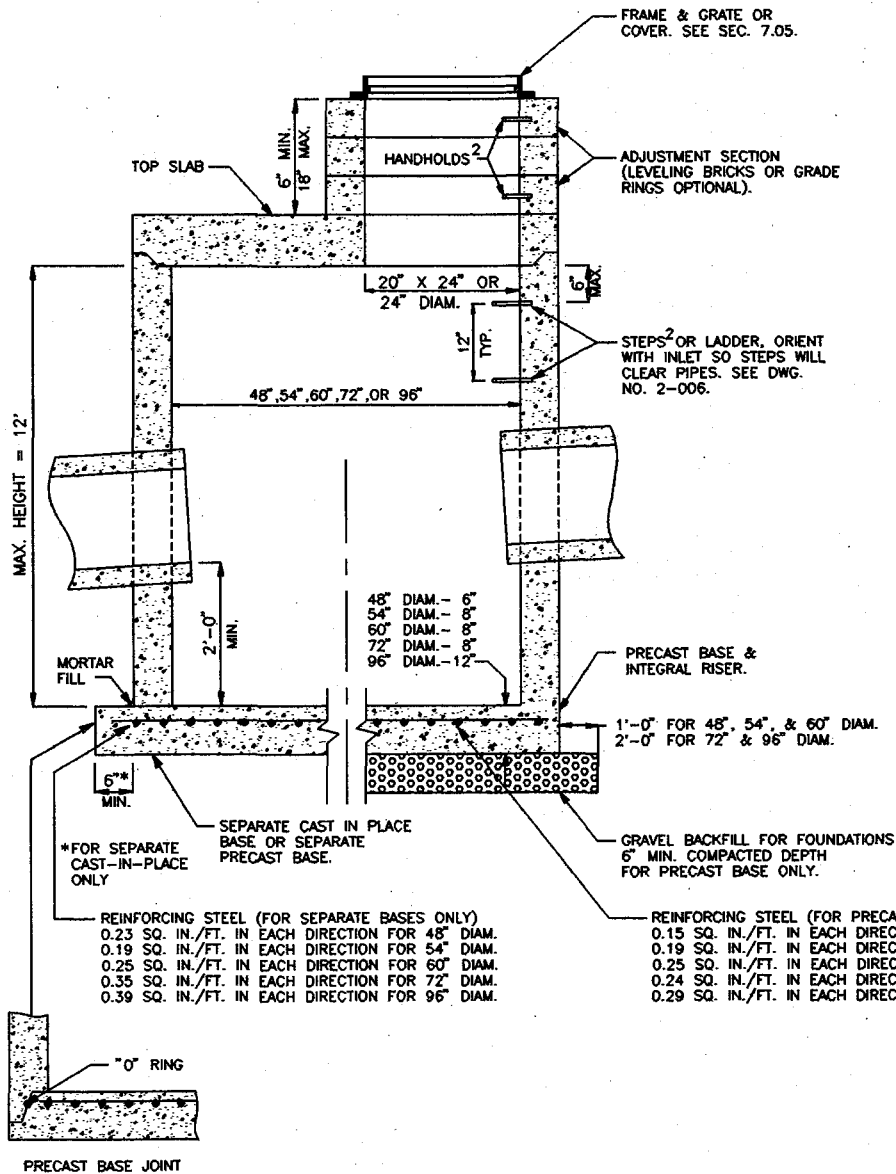

NOTES:

1. CATCH BASINS SHALL BE CONSTRUCTED IN ACCORDANCE WITH ASTM C478 (AASHTO M199) AND ASTM C890 UNLESS OTHERWISE SHOWN ON PLANS OR NOTED IN THE WSDOT/APWA STANDARD SPECIFICATIONS.
2. HANDHOLDS IN ADJUSTMENT SECTION SHALL HAVE 3" MIN. CLEARANCE. STEPS IN CATCH BASIN SHALL HAVE 6" MIN. CLEARANCE. SEE DWG. NO. 2-006, CATCH BASIN DETAILS. HANDHOLDS SHALL BE PLACED IN ALTERNATING GRADE RINGS OR LEVELING BRICK COURSE WITH A MIN. OF ONE HANDHOLD BETWEEN THE LAST STEP AND TOP OF THE MANHOLE.
3. ALL REINFORCED CAST-IN-PLACE CONCRETE SHALL BE CLASS 4000. ALL PRECAST CONCRETE SHALL BE CLASS 4000.
4. PRECAST BASES SHALL BE FURNISHED WITH CUTOUTS OR KNOCKOUTS. KNOCKOUTS SHALL HAVE WALL THICKNESS OF 2" MIN. UNUSED KNOCKOUTS NEED NOT BE GROUTED IF WALL IS LEFT INTACT. PIPES SHALL BE INSTALLED ONLY IN FACTORY KNOCKOUTS UNLESS OTHERWISE APPROVED BY THE ENGINEER.
5. KNOCKOUT OR CUTOUT HOLE SIZE SHALL EQUAL PIPE OUTER DIAM. PLUS CATCH BASIN WALL THICKNESS. MAX. HOLE SIZE SHALL BE 36" FOR 48" CATCH BASIN, 42" FOR 54" C.B., 48" FOR 60" C.B., 60" FOR 72" C.B., 84" FOR 96" C.B. MIN. DISTANCE BETWEEN HOLES SHALL BE 8" FOR 48", 54", AND 60" C.B.; 12" FOR 72" AND 96" C.B.
6. CATCH BASIN FRAMES AND GRATES OR COVERS SHALL BE IN ACCORDANCE WITH SEC. 7.05 AND MEET THE STRENGTH REQUIREMENTS OF FEDERAL SPECIFICATION RR-F-621D. MATING SURFACES SHALL BE FINISHED TO ASSURE NON-ROCKING FIT WITH ANY COVER POSITION.
7. ALL BASE REINFORCING STEEL SHALL HAVE A MIN. YIELD STRENGTH OF 60,000 PSI AND BE PLACED IN THE UPPER HALF OF THE BASE WITH 1" MIN. CLEARANCE.
8. MIN. SOIL BEARING VALUE SHALL EQUAL 3,300 POUNDS PER SQUARE FOOT.
9. FOR DETAILS SHOWING LADDER, STEPS, HANDRAILS AND TOP SLABS, SEE DWG. NO. 2-006.
10. SEE THE WSDOT/APWA STANDARD SPECIFICATIONS SEC. 7-05.3 FOR JOINT REQUIREMENTS.

DATE	REVISION	BY	APPR'D



KING COUNTY PUBLIC WORKS
KING COUNTY, WASHINGTON

CATCH BASIN TYPE 2 48", 54", 60", 72", & 96"

DWG. NO. 2-005

NOTES:

1. PROPRIETARY CATCH BASIN HANDHolds AND STEPS ARE ACCEPTABLE, PROVIDED THAT THEY CONFORM TO SEC. R, ASTM C478, AASHTO M-199 AND MEET ALL WISHA REQUIREMENTS.
2. CATCH BASIN STEP/HANDHOLD LEGS SHALL BE PARALLEL OR APPROXIMATELY RADIAL AT THE OPTION OF THE MANUFACTURER, EXCEPT THAT ALL STEPS IN ANY CATCH BASIN SHALL BE SIMILAR. PENETRATION OF OUTER WALL BY A LEG IS PROHIBITED.
3. HANDHolds AND STEPS SHALL HAVE "DROP" RUNGS AS SHOWN ON DETAIL OR PROTUBERANCES TO PREVENT SIDEWAYS SLIP.
4. SLAB OPENING MAY BE 24" X 20" OR 24" DIAM.
5. AS AN ACCEPTABLE ALTERNATIVE TO REBAR, WELDED WIRE FABRIC HAVING A MIN. AREA OF 0.12 SQUARE INCHES PER FOOT MAY BE USED. WELDED WIRE FABRIC SHALL COMPLY TO ASTM A497.
6. LADDERS OR STEPS SHALL EXTEND TO WITHIN 16" OF BOTTOM OF CATCH BASIN.
7. HANGING LADDERS SHALL BE PERMANENTLY FASTENED AT TOP BY HANGING ON STEP OR BY BOLTING OR EMBEDDING IN CONCRETE. EACH SHALL BE EMBEDDED AT BOTTOM IN BASE.
8. ADDITIONAL SAFETY FEATURES MAY BE REQUIRED IN VERY DEEP OR UNUSUAL STRUCTURES.

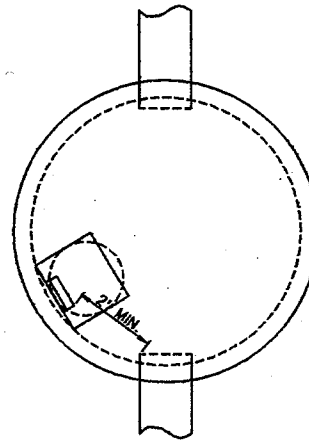
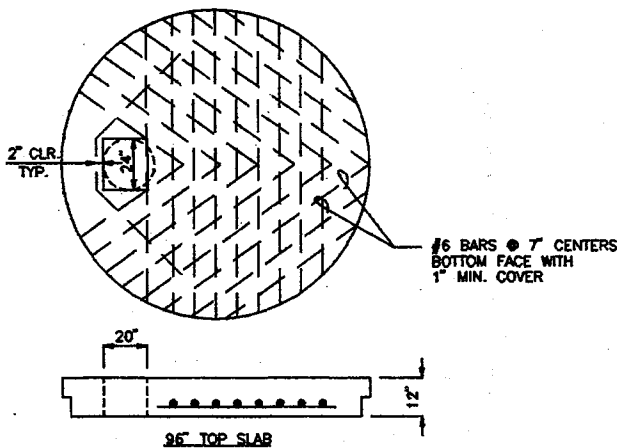
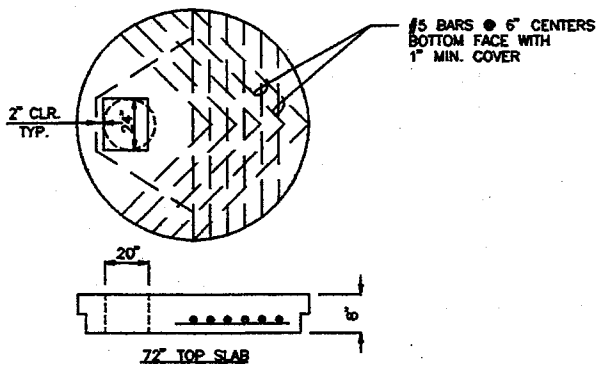
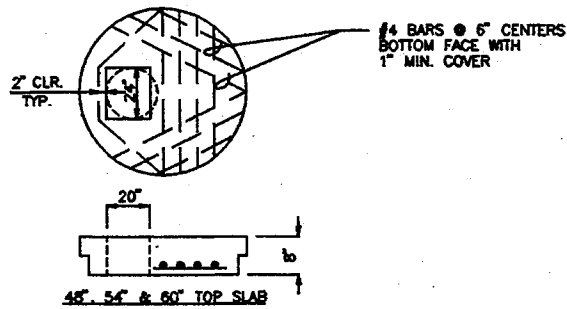

TYPICAL ORIENTATION
FOR ACCESS AND STEPS

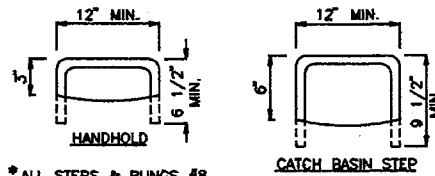

* ALL STEPS & RUNGS #8
GALV. DEFORMED REBAR
OR COPOLYMER PROPYLENE.

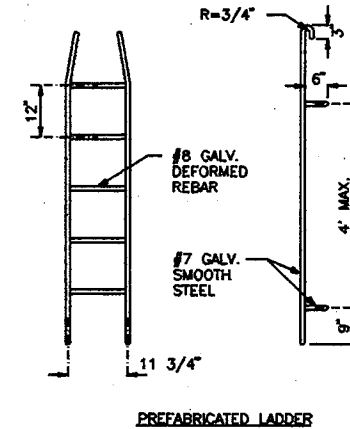
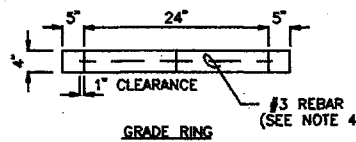
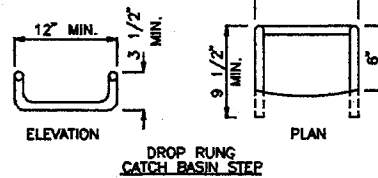

DATE	REVISION	BY	APPR'D



KING COUNTY PUBLIC WORKS
KING COUNTY, WASHINGTON

CATCH BASIN DETAILS

DWG. 2-006
NO.

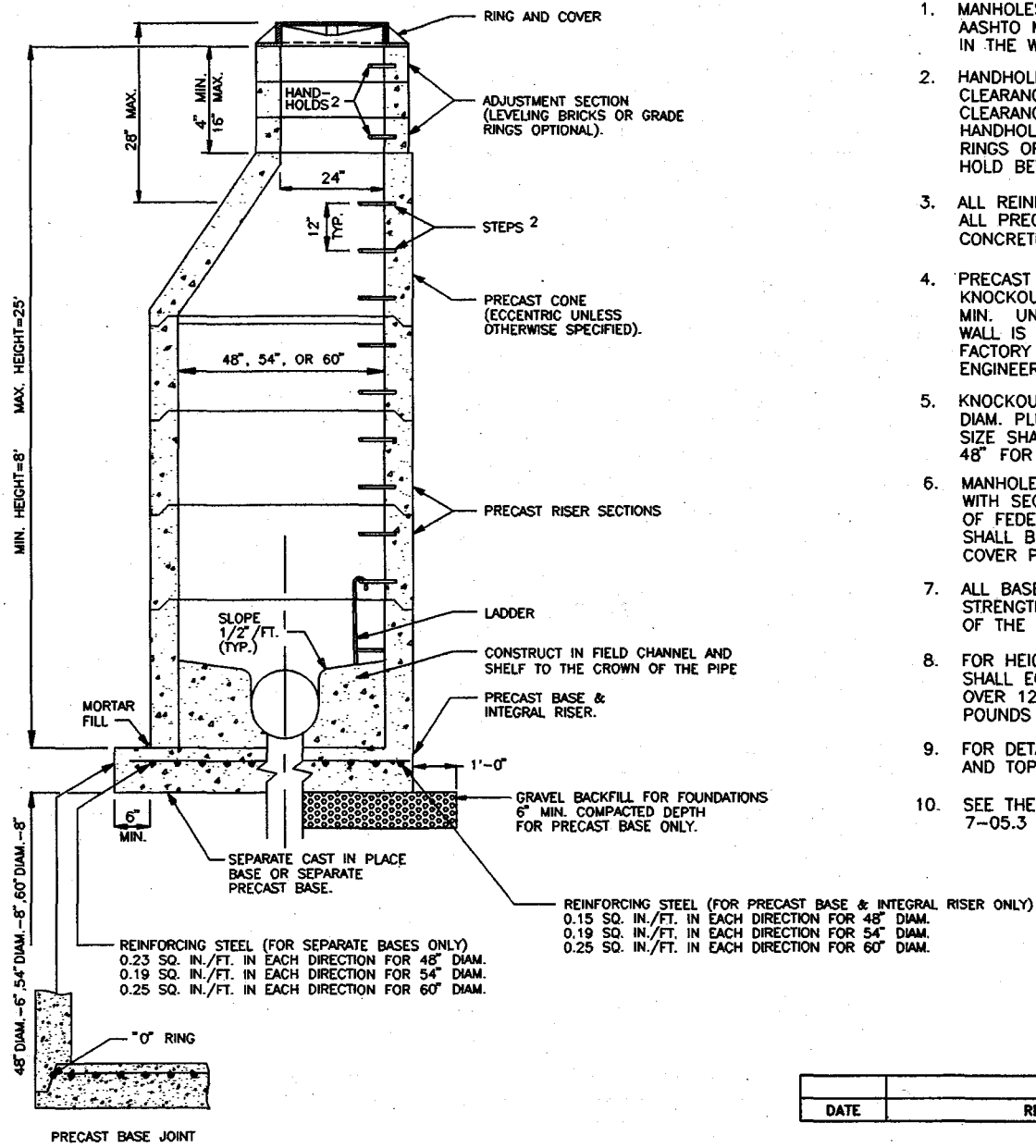

NOTES:

1. MANHOLES SHALL BE CONSTRUCTED IN ACCORDANCE WITH AASHTO M199 UNLESS OTHERWISE SHOWN ON PLANS OR NOTED IN THE WSDOT/APWA STANDARD SPECIFICATIONS.
2. HANDHOLDS IN ADJUSTMENT SECTION SHALL HAVE 3" MIN. CLEARANCE. STEPS IN MANHOLE SHALL HAVE 6" MIN. CLEARANCE. SEE DWG. NO. 2-011, "MANHOLE DETAILS." HANDHOLDS SHALL BE PLACED IN ALTERNATING GRADE RINGS OR LEVELING BRICK COURSE WITH A MIN. OF ONE HAND HOLD BETWEEN THE LAST STEP AND THE TOP OF THE MANHOLE.
3. ALL REINFORCED CAST-IN-PLACE CONCRETE SHALL BE CLASS 4000. ALL PRECAST CONCRETE SHALL BE CLASS 4000. NON-REINFORCED CONCRETE IN CHANNEL AND SHELF SHALL BE CLASS 3000.
4. PRECAST BASES SHALL BE FURNISHED WITH CUTOUTS OR KNOCKOUTS. KNOCKOUTS SHALL HAVE WALL THICKNESS OF 2" MIN. UNUSED KNOCKOUTS NEED NOT BE GROUTED IF WALL IS LEFT INTACT. PIPES SHALL BE INSTALLED ONLY IN FACTORY KNOCKOUTS UNLESS OTHERWISE APPROVED BY THE ENGINEER.
5. KNOCKOUT OR CUTOUT HOLE SIZE SHALL EQUAL PIPE OUTER DIAM. PLUS MANHOLE WALL THICKNESS. MAX. HOLE SIZE SHALL BE 36" FOR 48" MANHOLE, 42" FOR 54" MANHOLE, 48" FOR 60" M.H. MIN. DISTANCE BETWEEN HOLES SHALL BE 8".
6. MANHOLE RINGS AND COVERS SHALL BE IN ACCORDANCE WITH SEC. 7.05 AND MEET THE STRENGTH REQUIREMENTS OF FEDERAL SPECIFICATION RR-F-621D. MATING SURFACES SHALL BE FINISHED TO ASSURE NON-ROCKING FIT WITH ANY COVER POSITION.
7. ALL BASE REINFORCING STEEL SHALL HAVE A MIN. YIELD STRENGTH OF 60,000 PSI AND BE PLACED IN THE UPPER HALF OF THE BASE WITH 1" MIN. CLEARANCE.
8. FOR HEIGHTS OF 12' OR LESS, MIN. SOIL BEARING VALUE SHALL EQUAL 3,300 POUNDS PER SQUARE FOOT. FOR HEIGHTS OVER 12', MIN. SOIL BEARING VALUE SHALL EQUAL 3,800 POUNDS PER SQUARE FOOT.
9. FOR DETAILS SHOWING GRADE RING, LADDER, STEPS, HANDHOLDS, AND TOP SLABS, SEE DWG. NO. 2-011, "MANHOLE DETAILS."
10. SEE THE WSDOT/APWA STANDARD SPECIFICATIONS SEC. 7-05.3 FOR JOINT REQUIREMENTS.

DATE	REVISION	BY	APPR'D



KING COUNTY PUBLIC WORKS
KING COUNTY, WASHINGTON

MANHOLE TYPE 1 48", 54", & 60"

DWG. 2-007
NO.

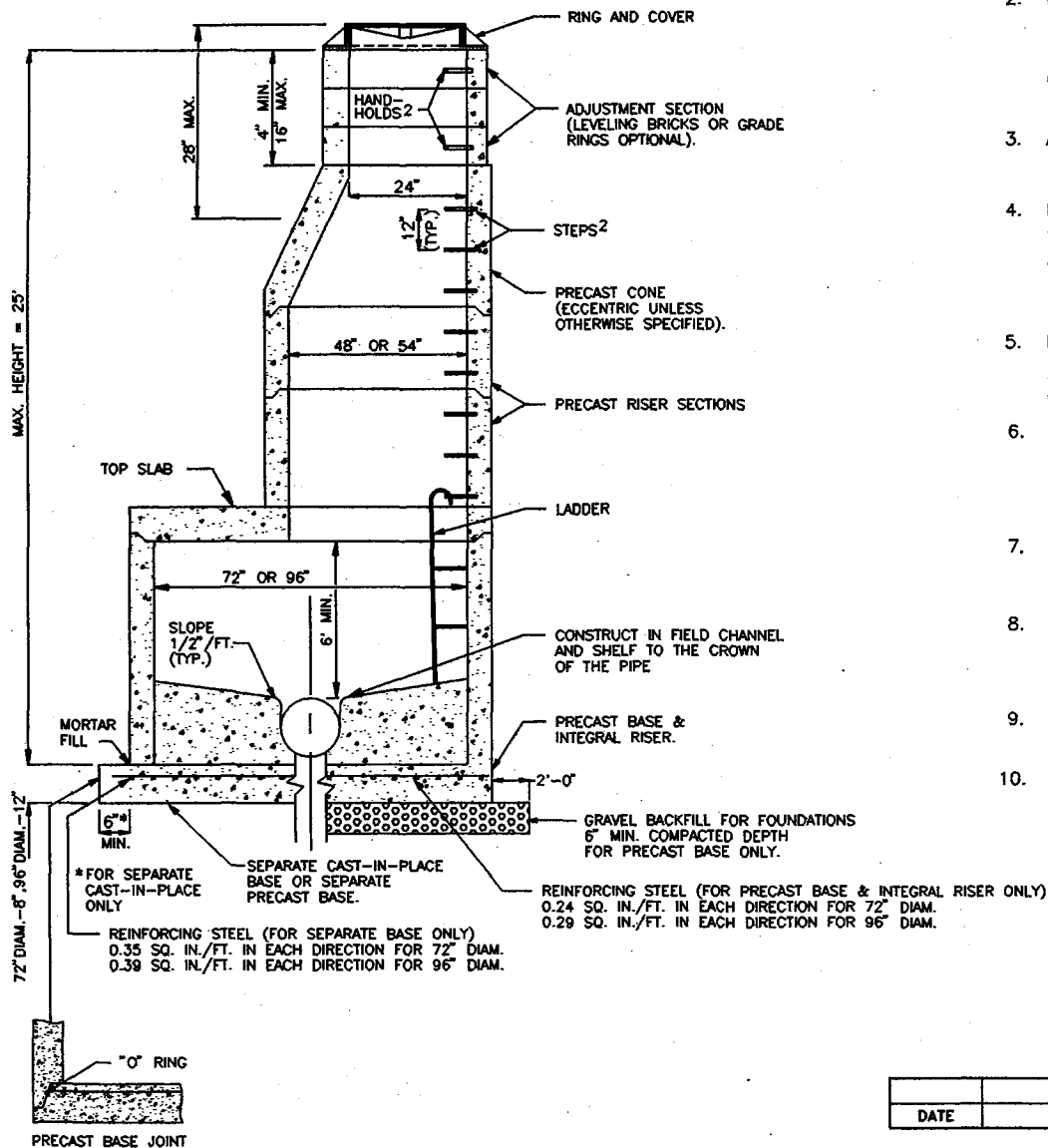

NOTES:

1. MANHOLES SHALL BE CONSTRUCTED IN ACCORDANCE WITH AASHTO M199 UNLESS OTHERWISE SHOWN ON PLANS OR NOTED IN THE WSDOT/APWA STANDARD SPECIFICATIONS.
2. HANDHOLDS IN ADJUSTMENT SECTION SHALL HAVE 3" MIN. CLEARANCE. STEPS IN MANHOLE SHALL HAVE 6" MIN. CLEARANCE. SEE DWG. NO. 2-011, "MANHOLE DETAILS." HANDHOLDS SHALL BE PLACED IN ALTERNATING GRADE RINGS OR LEVELING BRICK COURSE WITH MIN. OF ONE HANDHOLD BETWEEN THE LAST STEP AND THE TOP OF THE MANHOLE.
3. ALL REINFORCED CAST-IN-PLACE CONCRETE SHALL BE CLASS 4000. NON-REINFORCED CONCRETE IN CHANNEL AND SHELF SHALL BE CLASS 3000. ALL PRECAST CONCRETE SHALL BE CLASS 4000.
4. PRECAST BASES SHALL BE FURNISHED WITH CUTOUTS OR KNOCKOUTS. KNOCKOUTS SHALL HAVE WALL THICKNESS OF 2" MIN. UNUSED KNOCKOUTS NEED NOT BE GROUDED IF WALL IS LEFT INTACT. PIPES SHALL BE INSTALLED ONLY IN FACTORY KNOCKOUTS UNLESS OTHERWISE APPROVED BY THE ENGINEER.
5. KNOCKOUT OR CUTOUT HOLE SIZE SHALL EQUAL PIPE OUTER DIAM. PLUS MANHOLE WALL THICKNESS. MAX. HOLE SIZE SHALL BE 60" FOR 72" MANHOLE, 84" FOR 96" MANHOLE. MIN. DISTANCE BETWEEN HOLES SHALL BE 12".
6. MANHOLE RINGS AND COVERS SHALL BE IN ACCORDANCE WITH SEC. 7.05 AND MEET THE STRENGTH REQUIREMENTS OF FEDERAL SPECIFICATION RR-F-621D. MATING SURFACES SHALL BE FINISHED TO ASSURE NON-ROCKING FIT WITH ANY COVER POSITION.
7. ALL BASE REINFORCING STEEL SHALL HAVE A MIN. YIELD STRENGTH OF 60,000 PSI AND BE PLACED IN THE UPPER HALF OF THE BASE WITH 1" MIN. CLEARANCE.
8. FOR HEIGHTS OF 12" OR LESS, MIN. SOIL BEARING VALUE SHALL EQUAL 3,300 POUNDS PER SQUARE FOOT. FOR HEIGHTS OVER 12", MIN. SOIL BEARING VALUE SHALL EQUAL 3,800 POUNDS PER SQUARE FOOT.
9. FOR DETAILS SHOWING GRADE RING, LADDER, STEPS, HANDHOLDS, AND TOP SLABS, SEE DWG. NO. 2-011, "MANHOLE DETAILS."
10. SEE THE WSDOT/APWA STANDARD SPECIFICATIONS SEC. 7-05.3 FOR JOINT REQUIREMENTS.

DATE	REVISION	BY	APPR'D



KING COUNTY PUBLIC WORKS
KING COUNTY, WASHINGTON

MANHOLE TYPE 2

72" & 96"

DWG. NO. 2-008

NOTES:

1. MANHOLES SHALL BE CONSTRUCTED IN ACCORDANCE WITH AASHTO M199 UNLESS OTHERWISE SHOWN ON PLANS OR NOTED IN THE WSDOT/APWA STANDARD SPECIFICATIONS.
2. HANDHOLDS IN ADJUSTMENT SECTION SHALL HAVE 3" MIN. CLEARANCE. STEPS IN MANHOLE SHALL HAVE 6" MIN. CLEARANCE. SEE DWG. NO. 2-011, "MANHOLE DETAILS." HANDHOLDS SHALL BE PLACED IN ALTERNATING GRADE RINGS OR LEVELING BRICK COURSE WITH A MIN. OF ONE HANDHOLD BETWEEN THE LAST STEP AND THE TOP OF THE MANHOLE.
3. ALL REINFORCED CAST-IN-PLACE CONCRETE SHALL BE CLASS 4000. NON-REINFORCED CONCRETE IN CHANNEL AND SHELF SHALL BE CLASS 3000. ALL PRECAST CONCRETE SHALL BE CLASS 4000.
4. PRECAST BASES SHALL BE FURNISHED WITH CUTOUTS OR KNOCKOUTS. KNOCKOUTS SHALL HAVE WALL THICKNESS OF 2" MIN. UNUSED KNOCKOUTS NEED NOT BE GROUTED IF WALL IS LEFT INTACT. PIPES SHALL BE INSTALLED ONLY IN FACTORY KNOCKOUTS UNLESS OTHERWISE APPROVED BY THE ENGINEER.
5. KNOCKOUT OR CUTOUT HOLE SIZE SHALL EQUAL PIPE OUTER DIAM. PLUS MANHOLE WALL THICKNESS. MAX. HOLE SIZE SHALL BE 36" FOR 48" M.H., 42" FOR 54" M.H., 48" FOR 60" M.H., 60" FOR 72" M.H., 84" FOR 96" M.H. MIN. DISTANCE BETWEEN HOLES SHALL BE 8" FOR 48", 54", AND 60" M.H., 12" FOR 72" AND 96" M.H.
6. MANHOLE RINGS AND COVERS SHALL BE IN ACCORDANCE WITH SEC. 7.05 AND MEET THE STRENGTH REQUIREMENTS OF FEDERAL SPECIFICATION RR-F-621D. MATING SURFACES SHALL BE FINISHED TO ASSURE NON-ROCKING FIT WITH ANY COVER POSITION.
7. ALL BASE REINFORCING STEEL SHALL HAVE A MIN. YIELD STRENGTH OF 60,000 PSI AND BE PLACED IN THE UPPER HALF OF THE BASE WITH 1" MIN. CLEARANCE.
8. FOR HEIGHTS OF 12' OR LESS, MIN. SOIL BEARING VALUE SHALL EQUAL 3,300 POUNDS PER SQUARE FOOT. FOR HEIGHTS OVER 12', MIN. SOIL BEARING VALUE SHALL EQUAL 3,800 POUNDS PER SQUARE FOOT.
9. FOR DETAILS SHOWING GRADE RING, LADDER, STEPS, HANDHOLDS, AND TOP SLABS, SEE DWG. NO. 2-011, "MANHOLE DETAILS."
10. SEE THE WSDOT/APWA STANDARD SPECIFICATIONS SEC. 7-05.3 FOR JOINT REQUIREMENTS.

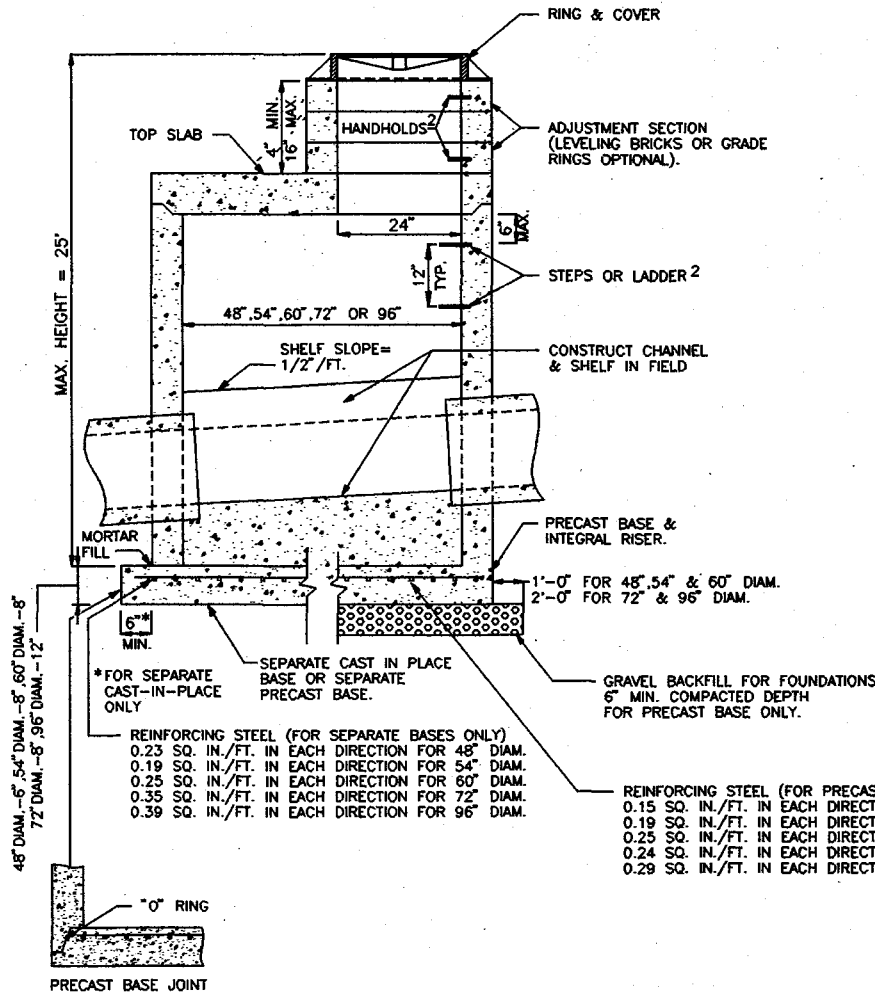

DATE	REVISION	BY	APPR'D



KING COUNTY PUBLIC WORKS
KING COUNTY, WASHINGTON

MANHOLE TYPE 3 48", 54", 60", 72", & 96"

DWG. 2-009
NO.

NOTES:

1. MANHOLES SHALL BE CONSTRUCTED IN ACCORDANCE WITH AASHTO M199 UNLESS OTHERWISE SHOWN ON PLANS OR NOTED IN THE WSDOT/APWA STANDARD SPECIFICATIONS.
2. HANDHOLDS IN ADJUSTMENT SECTION SHALL HAVE 3" MIN. CLEARANCE. STEPS IN MANHOLE SHALL HAVE 6" MIN. CLEARANCE. SEE DWG. NO. 2-011, "MANHOLE DETAILS."
3. MANHOLE RINGS AND COVERS SHALL BE IN ACCORDANCE WITH SEC. 7.05 AND MEET THE STRENGTH REQUIREMENTS OF FEDERAL SPECIFICATION RR-F-621D. MATING SURFACES SHALL BE FINISHED TO ASSURE NON-ROCKING FIT WITH ANY COVER POSITION.
4. ALL PRECAST CONCRETE SHALL BE CLASS 4000.
5. FOR DETAILS SHOWING GRADE RING, LADDER, STEPS, HANDHOLDS, AND TOP SLABS, SEE DWG. NO. 2-011, "MANHOLE DETAILS".
6. NOT FOR USE IN TRAFFIC BEARING AREAS.

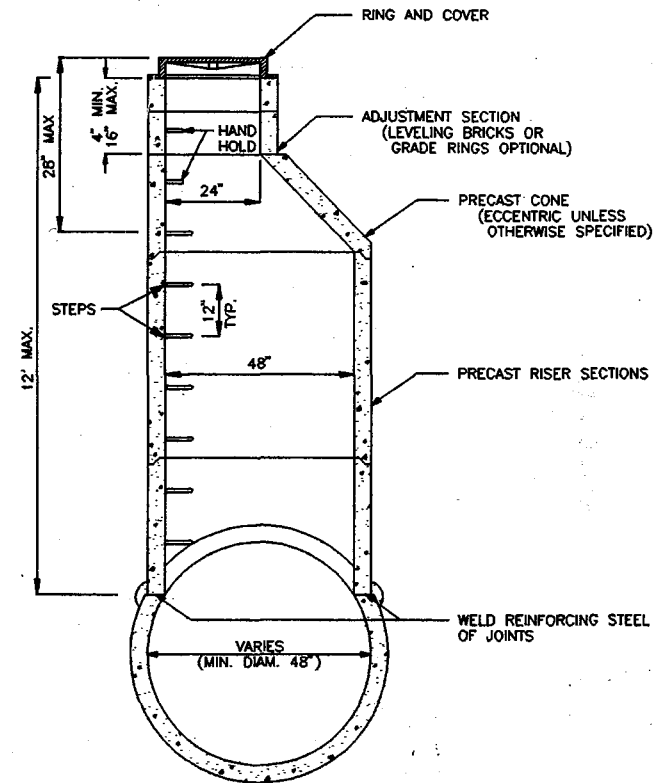
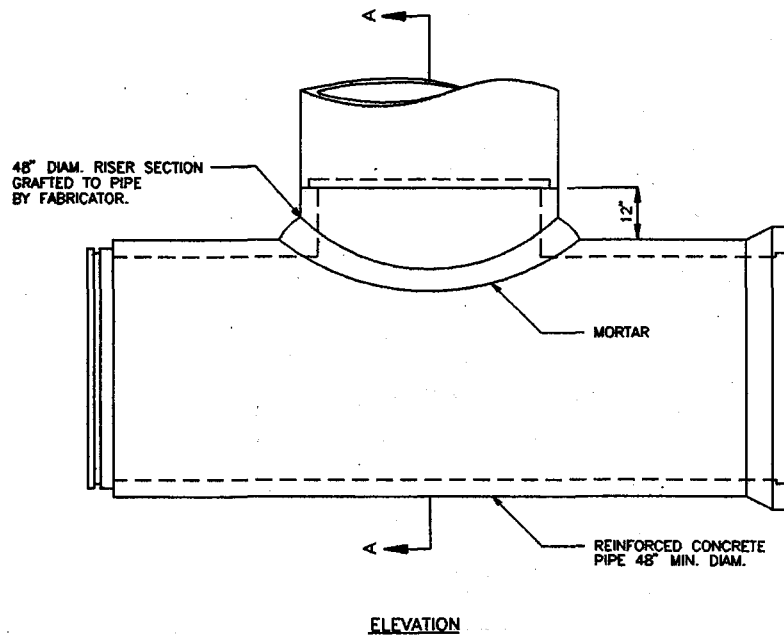

SECTION A-A

DATE	REVISION	BY	APPR'D



KING COUNTY PUBLIC WORKS
KING COUNTY, WASHINGTON

MANHOLE TYPE 4

DWG. NO. 2-010

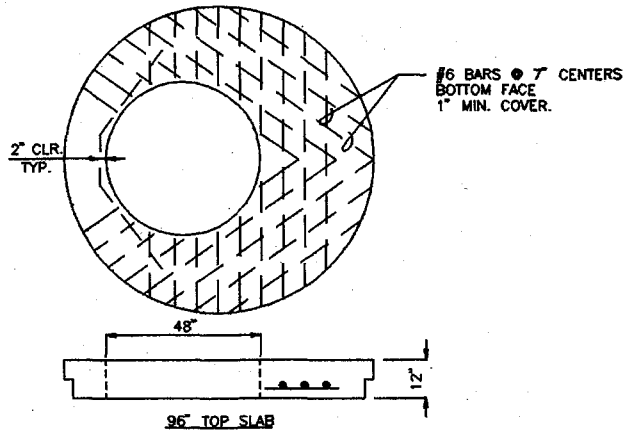
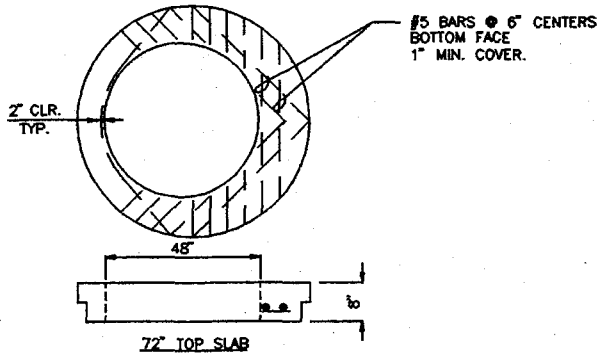
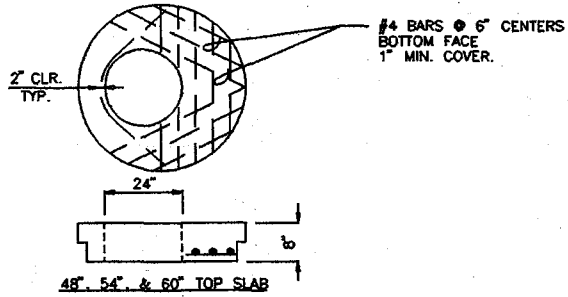

*ALL STEPS & RUNGS
1" DIAM. GALV. REBAR OR
COPOLYMER PROPYLENE.

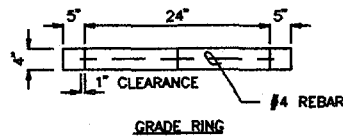
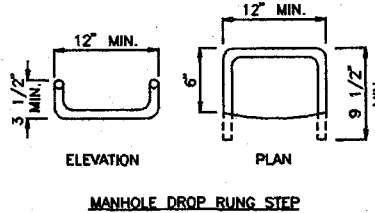
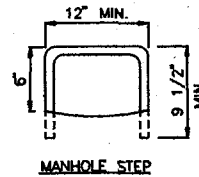
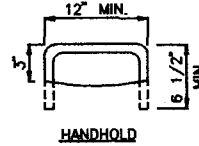

NOTES:

1. PROPRIETARY MANHOLE HANDHOLDS AND STEPS ARE ACCEPTABLE, PROVIDED THAT THEY CONFORM TO SEC. R, ASTM C478, AASHTO M199 AND MEET ALL WISHA REQUIREMENTS.
2. MANHOLE STEP/HANDHOLD LEGS SHALL BE PARALLEL OR APPROXIMATELY RADIAL AT THE OPTION OF THE MANUFACTURER, EXCEPT THAT ALL STEPS IN ANY MANHOLE SHALL BE SIMILAR. PENETRATION OF OUTER WALL BY A LEG IS PROHIBITED.
3. HANDHOLDS AND STEPS SHALL HAVE "DROP" RUNGS OR PROTUBERANCES TO PREVENT SIDEWAYS SLIP.
4. LADDERS OR STEPS SHALL EXTEND TO WITHIN 16" OF BOTTOM OF MANHOLE.
5. HANGING LADDERS SHALL BE PERMANENTLY FASTENED AT TOP BY HANGING ON STEP OR BY BOLTING OR EMBEDDING IN CONCRETE. EACH SHALL BE EMBEDDED AT BOTTOM IN BASE.
6. ADDITIONAL SAFETY FEATURES MAY BE REQUIRED IN VERY DEEP OR UNUSUAL STRUCTURES.

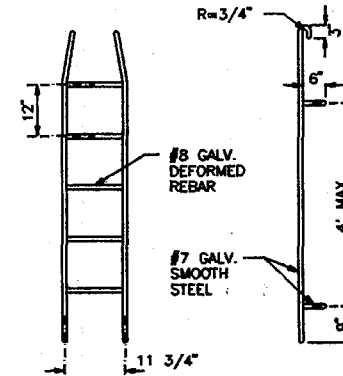

DATE	REVISION	BY	APPR'D



KING COUNTY PUBLIC WORKS
KING COUNTY, WASHINGTON

MANHOLE DETAILS

DWG. 2-011
NO.

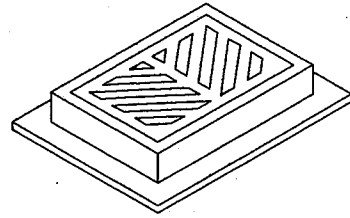

FRAME AND GRATE
SEE SEC. 7.05 AND
APPLICABLE DWGS.

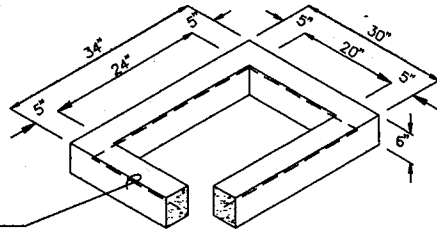

6" RISER SECTION

1 #3 BAR HOOP

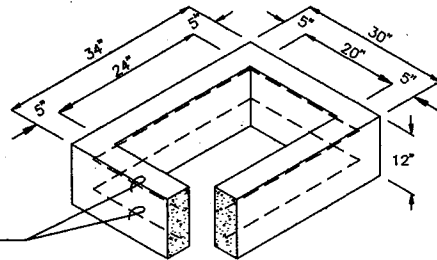

12" RISER SECTION

2 #3 BAR HOOPS

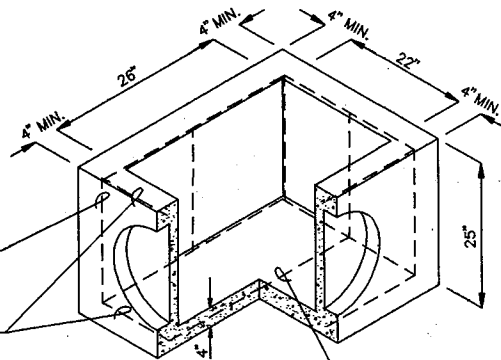

PRECAST BASE SECTION
(MEASUREMENT AT THE TOP
OF THE BASE)

#3 BAR EACH CORNER

#3 BAR EACH SIDE
TOP & BOTTOM

1-#3 BAR ACROSS BOTTOM

NOTES:

1. CURB INLET TO BE CONSTRUCTED IN ACCORDANCE WITH ASTM C478 & C890 UNLESS OTHERWISE SHOWN ON PLANS OR NOTED IN THE STANDARD SPECIFICATIONS.
2. AS AN ACCEPTABLE ALTERNATIVE TO REBAR, WELDED WIRE FABRIC HAVING A MIN. AREA OF 0.12 SQUARE INCHES PER FOOT MAY BE USED. WELDED WIRE FABRIC SHALL COMPLY TO ASTM A497. WIRE FABRIC SHALL NOT BE PLACED IN KNOCKOUTS.
3. ALL REINFORCED CAST-IN-PLACE CONCRETE SHALL BE CLASS 4000.
4. PRECAST BASES SHALL BE FURNISHED WITH CUTOUTS OR KNOCKOUTS. KNOCKOUTS SHALL HAVE A WALL THICKNESS OF 2" MIN. ALL PIPE SHALL BE INSTALLED IN FACTORY PROVIDED KNOCKOUTS. UNUSED KNOCKOUTS NEED NOT BE GROUTED IF WALL IS LEFT INTACT.
5. KNOCKOUT OR CUTOUT HOLE SIZE IS EQUAL TO PIPE OUTER DIAM. PLUS CURB INLET WALL THICKNESS.
6. ROUND KNOCKOUTS MAY BE ON ALL 4 SIDES WITH MAX. DIAM. OF 17".
7. THE MAX. DEPTH FROM THE FINISHED GRADE TO THE PIPE INVERT IS 5'-0".
8. THE TAPER ON THE SIDES OF THE PRECAST BASE SECTION AND RISER SECTION SHALL NOT EXCEED 1/2"/FT.
9. CONCRETE INLET FRAME AND GRATES SHALL BE IN ACCORDANCE WITH STANDARD SPECIFICATIONS AND MEET THE STRENGTH REQUIREMENTS OF FEDERAL SPECIFICATION RR-F-62ID. MATING SURFACES SHALL BE FINISHED TO ASSURE NON-ROCKING FIT WITH ANY OTHER COVER POSITION.
10. FRAME AND GRATE MAY BE INSTALLED WITH FLANGE DOWN OR CAST INTO RISER.

DATE	REVISION	BY	APPR'D



KING COUNTY PUBLIC WORKS
KING COUNTY, WASHINGTON

CURB INLET

DWG. 2-012
NO.

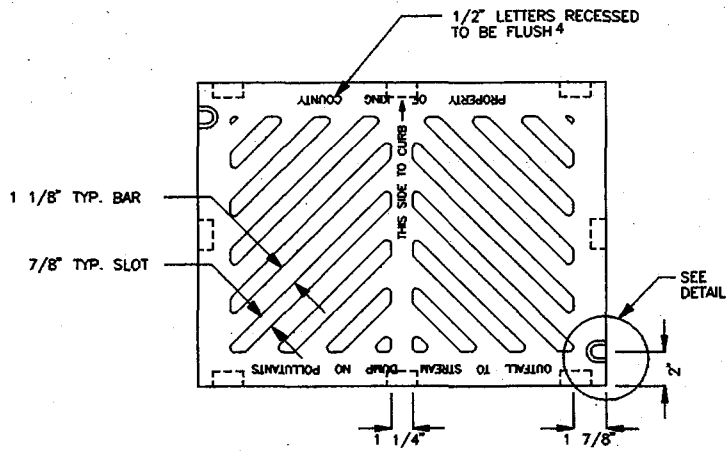

TOP VIEW

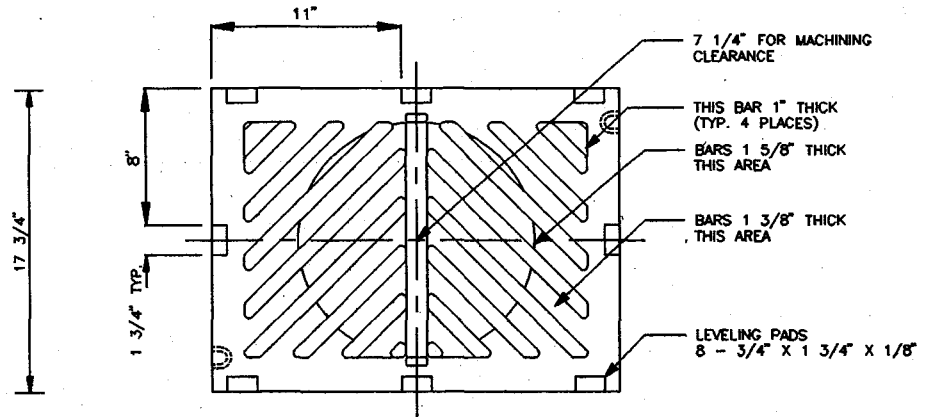

BOTTOM VIEW

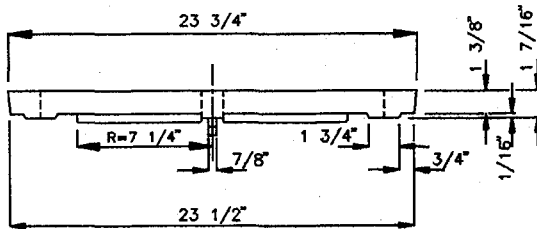

SIDE VIEW

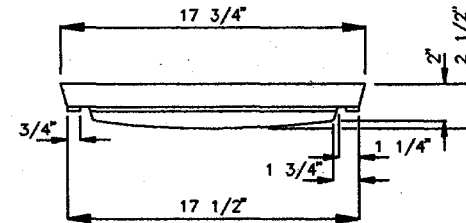

END VIEW

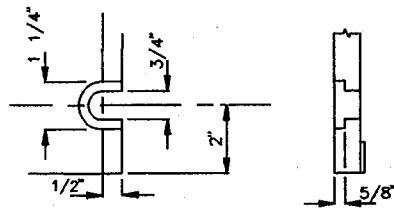

SLOT DETAIL

SEE NOTE 1

NOTES:

1. SLOT FORMED AND RECESSED FOR 5/8"-11 NC X 2" SOCKET HEAD (ALLEN HEAD) CAP SCREW.
2. GRATE SHALL BE CAST IRON PER ASTM A48 CLASS 30 UNLESS OTHERWISE SPECIFIED.
3. SEE SEC. 7.05.
4. THE WORDS "PROPERTY OF KING COUNTY" SHALL BE OMITTED IF GRATE IS ON PRIVATE SYSTEM.

DATE	REVISION	BY	APPR'D



KING COUNTY PUBLIC WORKS
KING COUNTY, WASHINGTON

STANDARD GRATE

DWG. 2-013
NO.

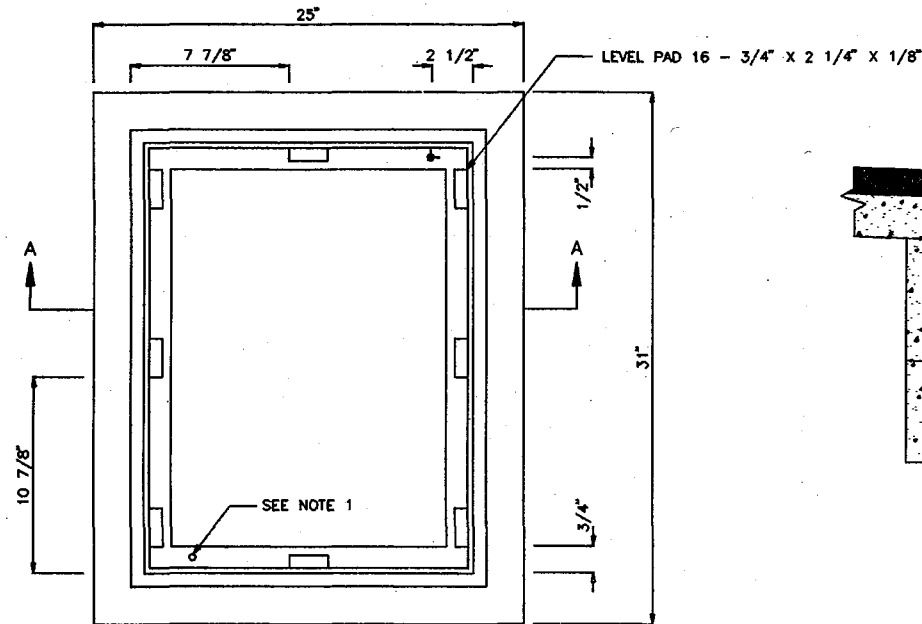

PLAN

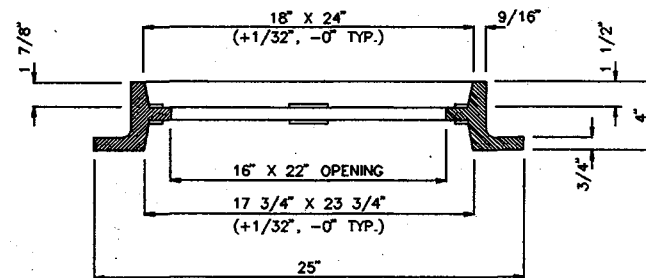

SECTION A-A

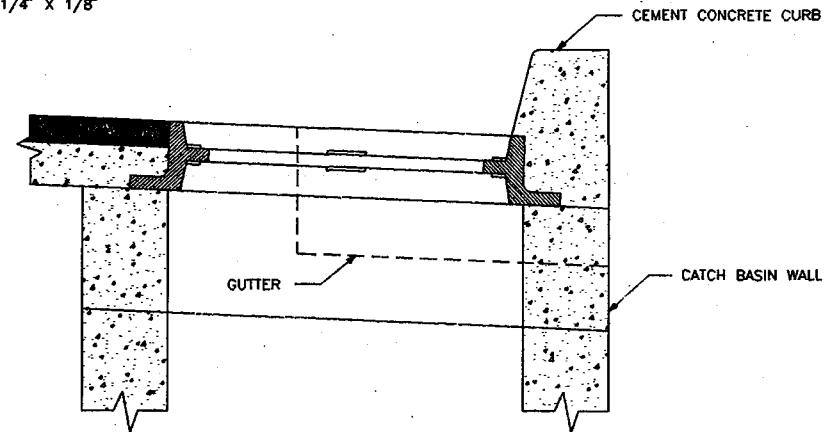

VERTICAL CURB

SEE NOTE 4

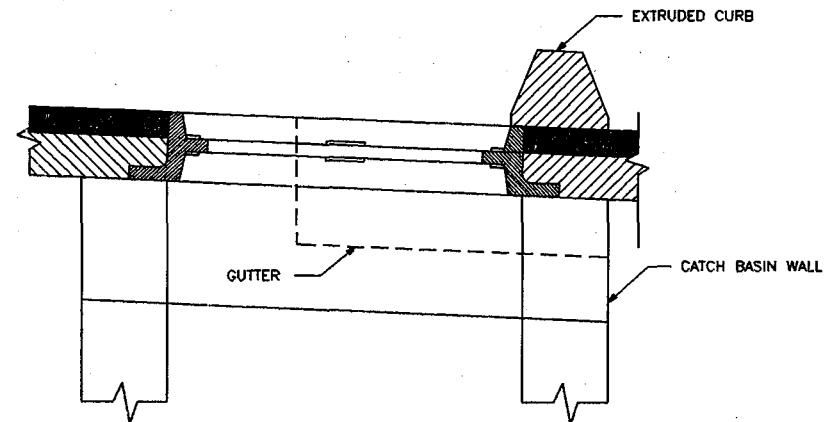

EXTRUDED CURB

SEE NOTE 4

NOTES:

1. DRILL AND TAP FOR, AND PROVIDE, TWO LOCKING BOLTS 5/8"-11 NC STAINLESS TYPE 304 STEEL SOCKET HEAD (ALLEN HEAD) CAP SCREWS 2" LONG WHEN USED WITH SOLID COVER (DWG. NO. 2-015) OR WHEN SPECIFIED BY ENGINEER.
2. FRAME MATERIAL IS CAST IRON PER ASTM A48 CLASS 30.
3. SET FRAME TO GRADE AND CONSTRUCT ROAD AND GUTTER TO BE FLUSH WITH FRAME.
4. SEE SEC. 7.05.

DATE	REVISION	BY	APPR'D



KING COUNTY PUBLIC WORKS
KING COUNTY, WASHINGTON

STANDARD FRAME WITH VERTICAL OR
EXTRUDED CURB INSTALLATION

DWG. NO. 2-014

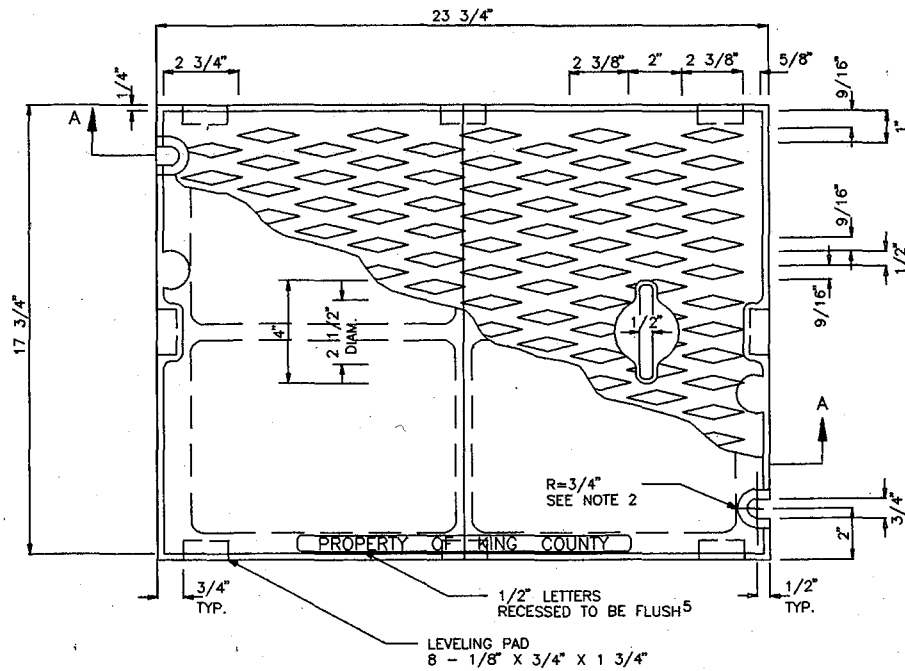

PLAN COVER

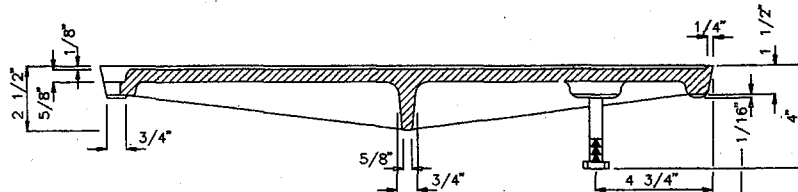

SECTION A-A

FINISH DIM. ON LEVELING PAD.

NOTES:

1. USE WITH FRAME (DWG. NO. 2-014) DRILLED AND TAPPED FOR LOCKING BOLTS.
2. USE WITH TWO LOCKING BOLTS 5/8"-11 NC STAINLESS STEEL TYPE 304 STEEL SOCKET HEAD (ALLEN HEAD) CAP SCREWS, 2" LONG.
3. MATERIAL IS CAST IRON PER ASTM A48 CLASS 30.
4. SEE SEC. 7.05.
5. THE WORDS "PROPERTY OF KING COUNTY" SHALL BE OMITTED IF COVER IS ON A PRIVATE SYSTEM.

DATE	REVISION	BY	APPR'D



KING COUNTY PUBLIC WORKS
KING COUNTY, WASHINGTON

SOLID COVER

DWG. 2-015
NO.

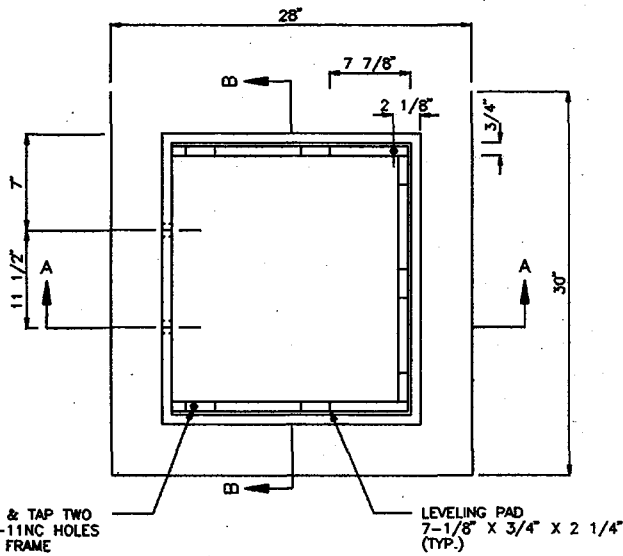

PLAN

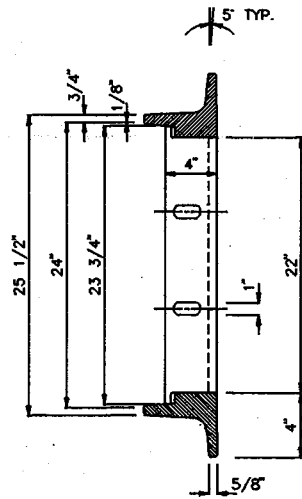

SECTION B-B

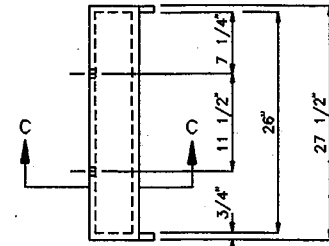

HOOD DETAIL

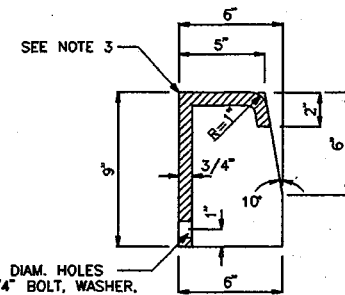

SECTION C-C

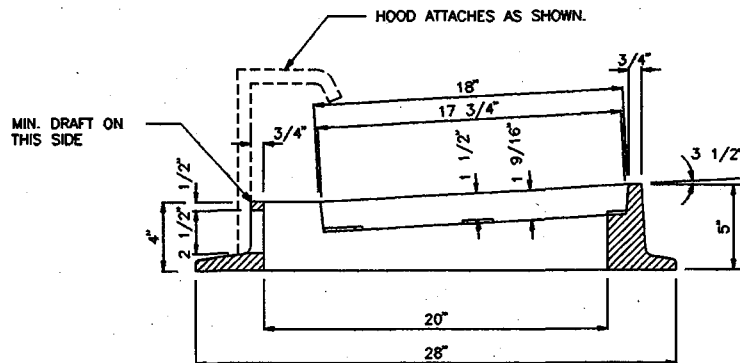

SECTION A-A

NOTES:

1. MATERIAL IS CAST IRON ASTM A48 CLASS 30.
2. SEE DWG. NO. 2-018 FOR VANED GRATE.
3. PATTERN ON TOP SURFACE OF HOOD SHALL BE 3/16" NON-SKID DIAMOND.
4. BOLT, WASHER, AND NUT SHALL BE GALV. OR CORROSION RESISTANT.
5. SEE SEC. 7.05.

DATE	REVISION	BY	APPR'D



KING COUNTY PUBLIC WORKS
KING COUNTY, WASHINGTON

THROUGH-CURB INLET FRAME

DWG. 2-016
NO.

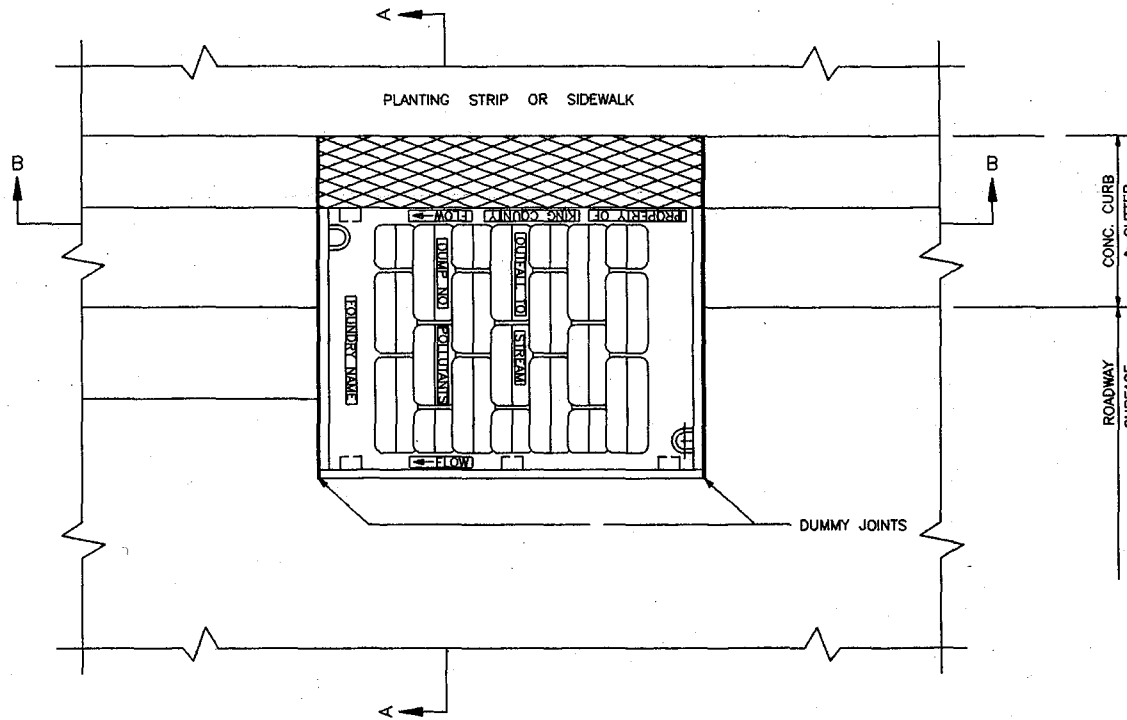

PLAN

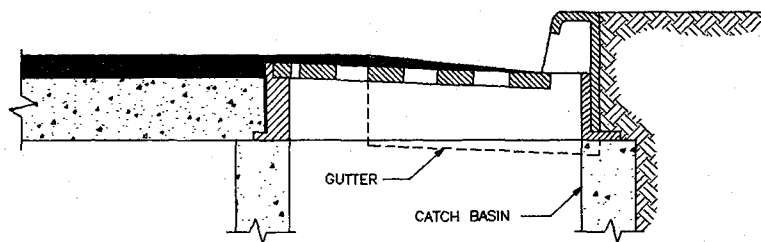

SECTION A-A

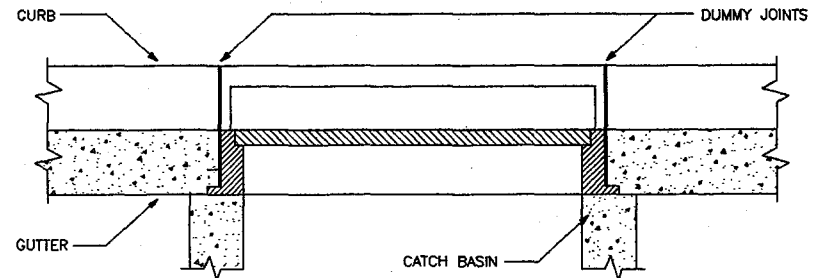

SECTION B-B

NOTES:

1. SET TO GRADE AND CONSTRUCT ROAD AND GUTTER TO BE FLUSH WITH FRAME.
2. SEE SEC. 3.04 FOR JOINT REQUIREMENTS.

DATE	REVISION	BY	APPR'D



KING COUNTY PUBLIC WORKS
KING COUNTY, WASHINGTON

THROUGH-CURB INLET FRAME & GRATE WITH
VERTICAL CURB INSTALLATION

DWG. 2-017
NO.

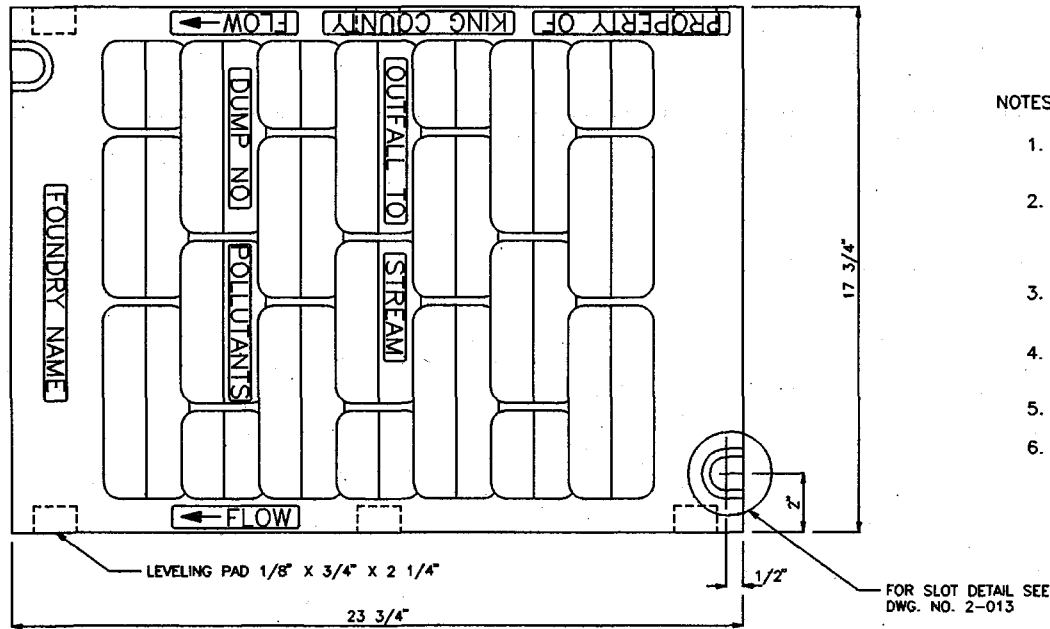

NOTES:

1. SELF-LOCK VANED GRATE MANUFACTURER SUBJECT TO APPROVAL BY ENGINEER.
2. USE WITH TWO LOCKING BOLTS 5/8" - 11 NC STAINLESS TYPE 304 STEEL SOCKET HEAD (ALLEN HEAD) CAP SCREWS 2" LONG. NOTE SLOT DETAIL.
3. MATERIAL IS DUCTILE IRON ASTM A536 GRADE 80-55-06.
4. "OUTFALL TO STREAM DUMP NO POLLUTANTS" MAY BE LOCATED ON BORDER AREA.
5. SEE SEC. 7.05.
6. THE WORDS "PROPERTY OF KING COUNTY" SHALL BE OMITTED IF GRATE IS ON PRIVATE SYSTEM.

PLAN

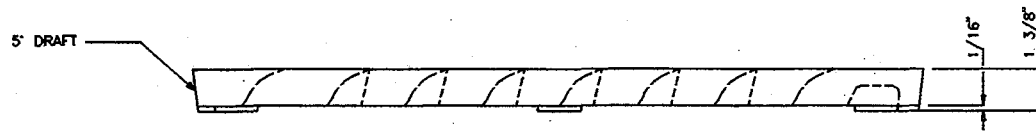

ELEVATION

DATE	REVISION	BY	APPR'D



KING COUNTY PUBLIC WORKS
KING COUNTY, WASHINGTON

VANED GRATE

DWG. 2-018
NO.

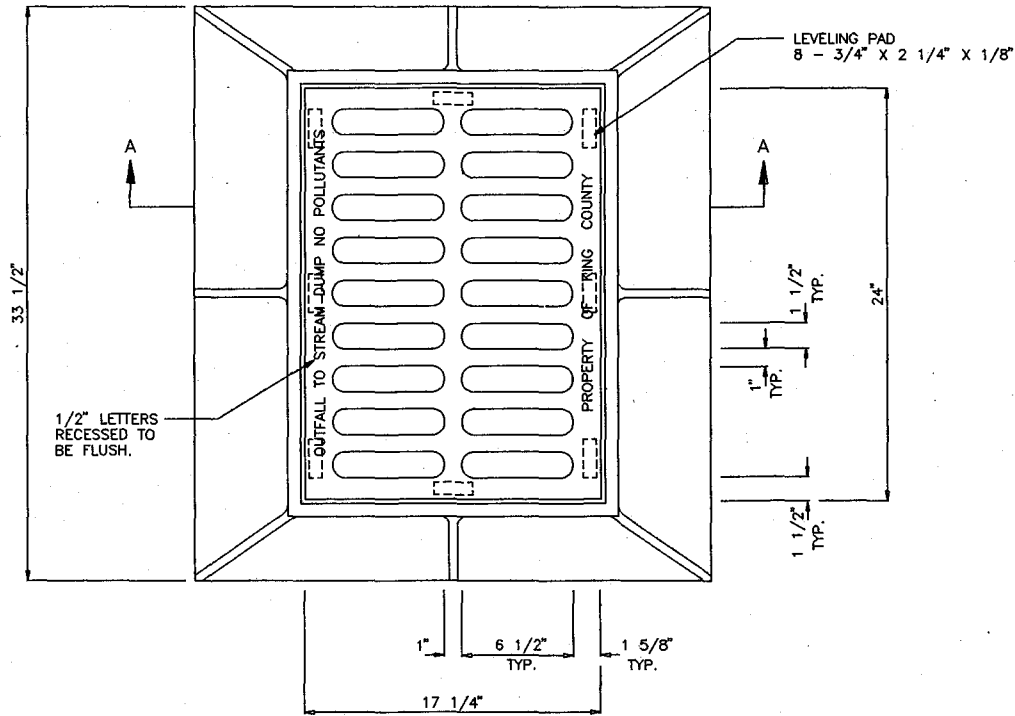

PLAN

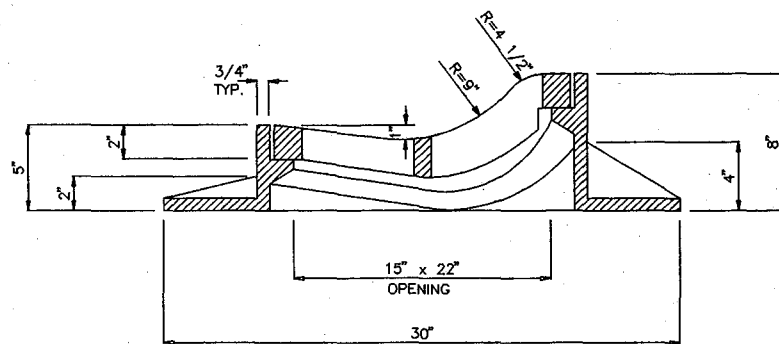

SECTION A-A

NOTES:

1. MATERIAL IS CAST IRON ASTM A48 CLASS 30.
2. SEE SEC. 7.05.
3. THE WORDS "PROPERTY OF KING COUNTY" SHALL BE OMITTED IF ON A PRIVATE SYSTEM.
4. NOT TO BE USED ON THICKENED EDGE ROADWAYS.

DATE	REVISION	BY	APPR'D



KING COUNTY PUBLIC WORKS
KING COUNTY, WASHINGTON

ROLLED CURB FRAME & GRATE

DWG. 2-019
NO.

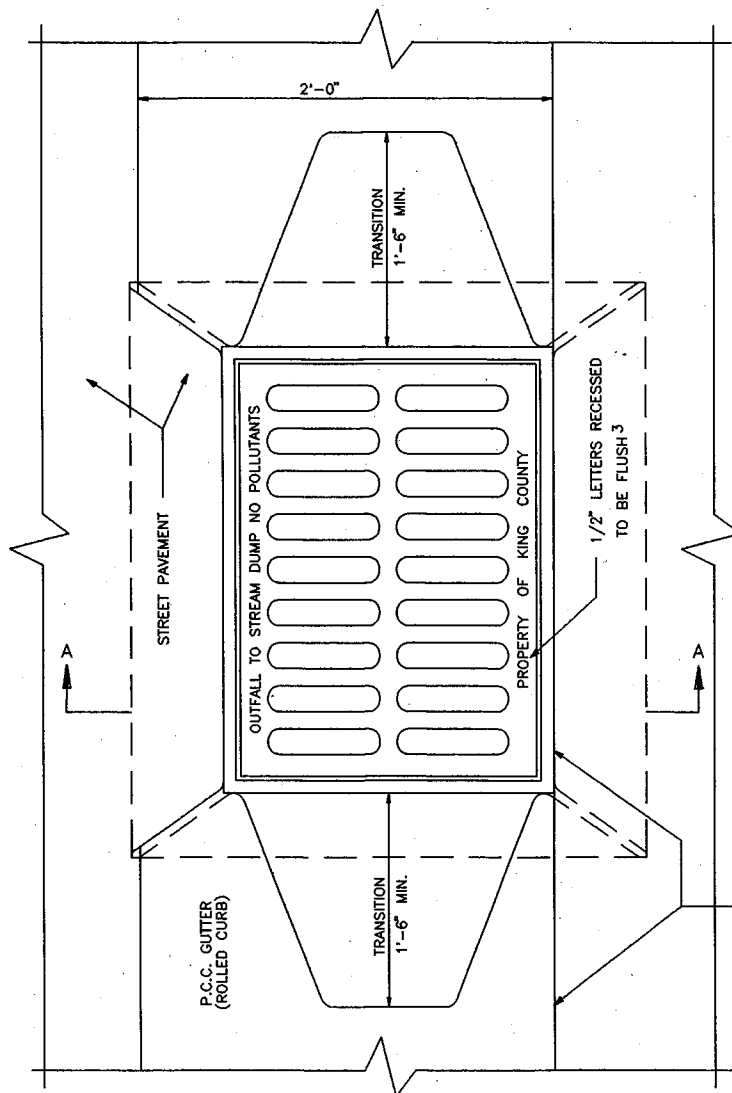

PLAN

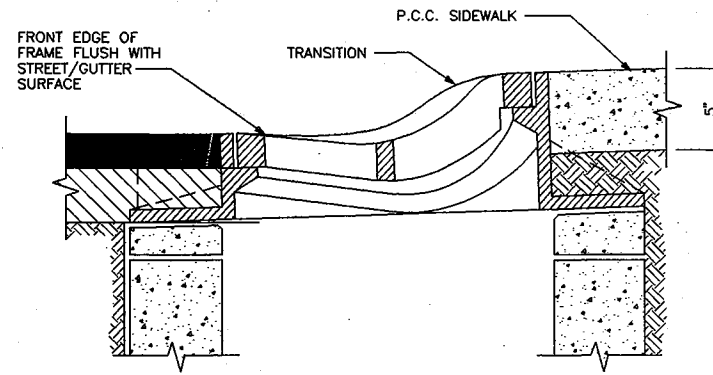

SECTION A-A

NOTES:

1. SET FRAME TO GRADE AND CONSTRUCT ROAD AND CURB TO BE FLUSH AT FRONT AND BACK OF FRAME.
2. SEE SEC. 7.05.
3. THE WORDS "PROPERTY OF KING COUNTY" SHALL BE OMITTED IF GRATE IS ON A PRIVATE SYSTEM.
4. NOT TO BE USED ON THICKENED EDGE ROADWAYS.

BACK EDGE OF FRAME EVEN WITH BACK FACE OF CURB

DATE	REVISION	BY	APPR'D



KING COUNTY PUBLIC WORKS
KING COUNTY, WASHINGTON

ROLLED CURB FRAME & GRATE INSTALLATION

DWG. 2-020
NO.

1/2" LETTERS
RECESSED TO
BE FLUSH

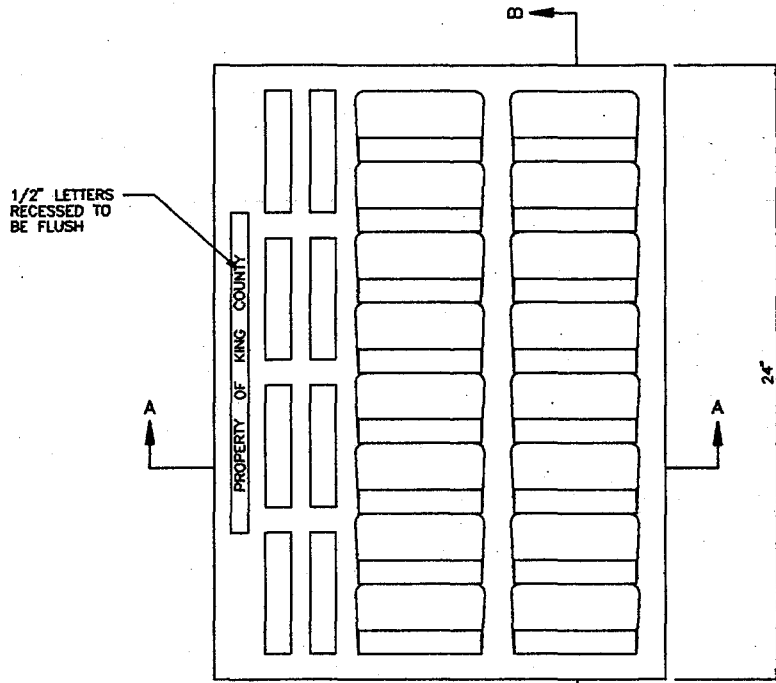

17 1/2"

PLAN

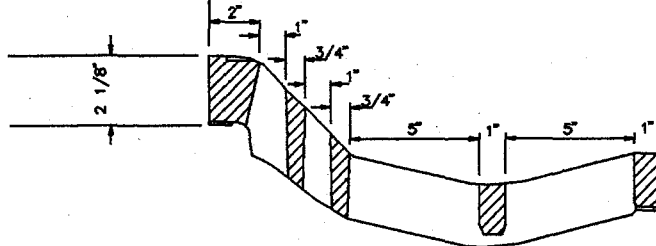

SECTION A-A

NOTES:

1. MATERIAL IS CAST IRON ASTM A48 CLASS 30.
2. SEE SEC. 7.05.
3. THE WORDS "PROPERTY OF KING COUNTY" SHALL BE OMITTED IF ON A PRIVATE SYSTEM.

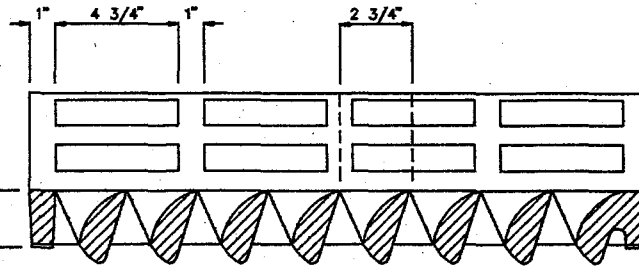

SECTION B-B

DATE	REVISION	BY	APPR'D



KING COUNTY PUBLIC WORKS
KING COUNTY, WASHINGTON

ROLLED CURB VANED GRATE

DWG. NO. 2-021

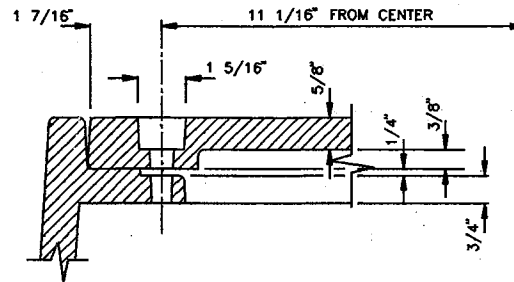
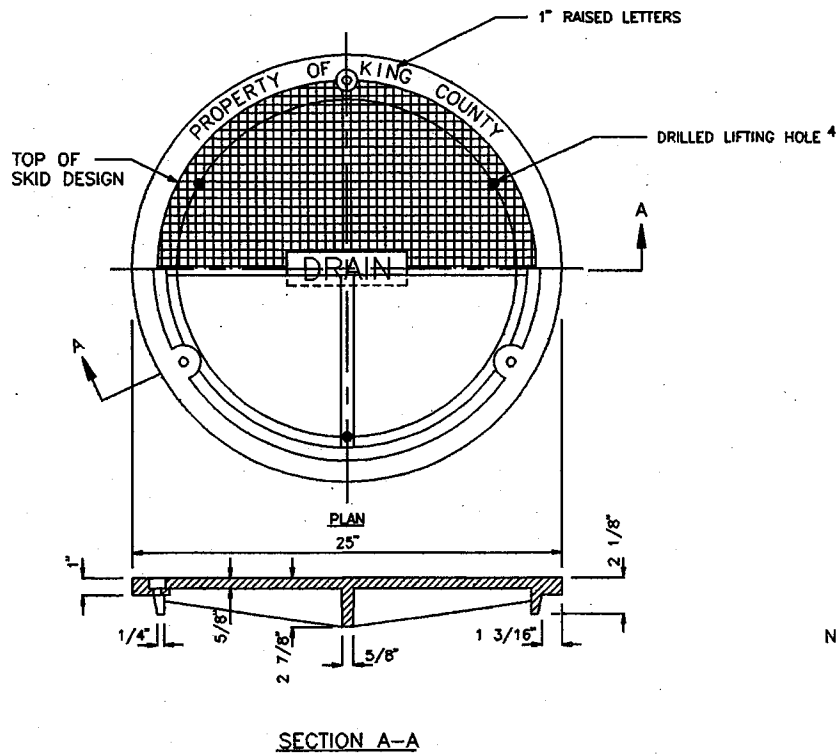

BOLT-DOWN DETAIL

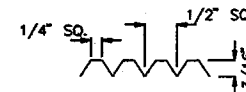

COVER SKID DESIGN DETAIL

NOTES:

1. USE WITH THREE LOCKING BOLTS 5/8"-11 NC STAINLESS TYPE 304 STEEL SOCKET HEAD (ALLEN HEAD) CAP SCREWS 2" LONG. DRILL HOLES SPACED 120° AT 11 1/16" RADIUS.
2. MATERIAL IS DUCTILE IRON ASTM A536 GRADE 80-55-06
3. SEE SEC. 7.05.
4. DRILL THREE 1 INCH HOLES SPACED AT 120° AND 9 1/2" RADIUS.

DATE	REVISION	BY	APPR'D



KING COUNTY PUBLIC WORKS
KING COUNTY, WASHINGTON

LOCKING MANHOLE COVER

DWG. NO. 2-022

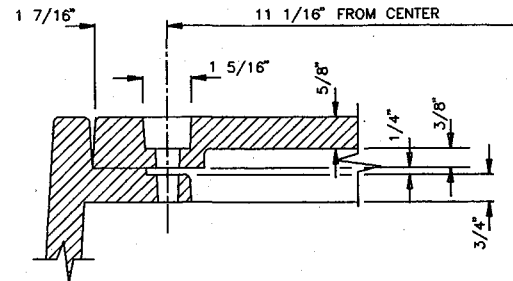
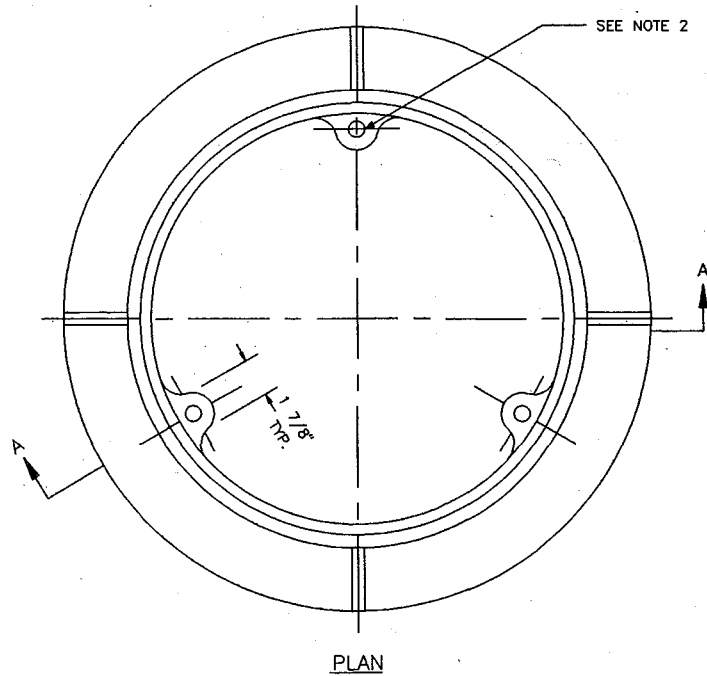

BOLT-DOWN DETAIL

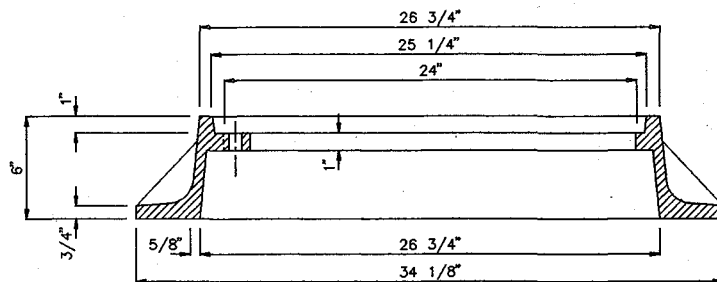

SECTION A-A

NOTES:

1. MATERIAL IS CAST IRON ASTM A48 CLASS 30.
2. DRILL AND TAP THREE 5/8"-11 NC HOLES THROUGH FRAME AT 120° AND 11 1/16" RADIUS.
3. SEE SEC. 7.05.

DATE	REVISION	BY	APPR'D



KING COUNTY PUBLIC WORKS
KING COUNTY, WASHINGTON

LOCKING MANHOLE FRAME

DWG. 2-023
NO.

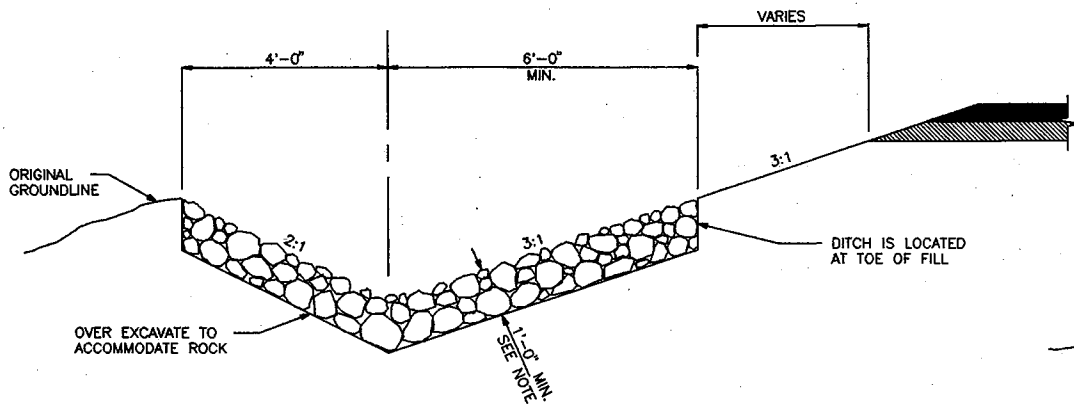

ROCK-LINED SHOULDER DITCH
IN FILL SECTION

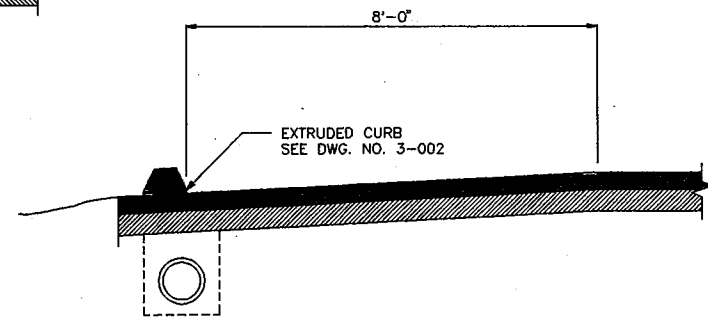

CURBED SHOULDER

NOTES:

1. DEEPER ROCK FILL MAY BE SPECIFIED.
2. SEE SEC. 7.02.

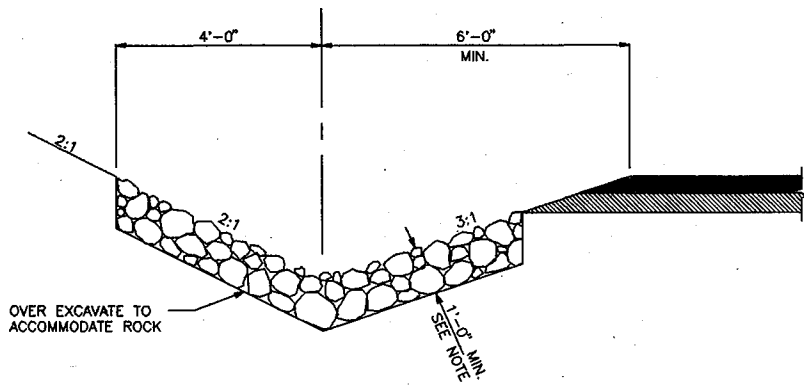

ROCK-LINED SHOULDER DITCH
IN CUT SECTION

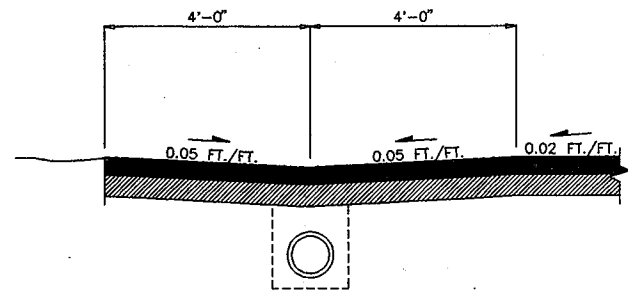

TURNPIKE SHOULDER

DATE	REVISION	BY	APPR'D



KING COUNTY PUBLIC WORKS
KING COUNTY, WASHINGTON

ROCK-LINED SHOULDER DITCHES & CURBED
OR TURNPIKE SHOULDERS

DWG. NO. 2-024

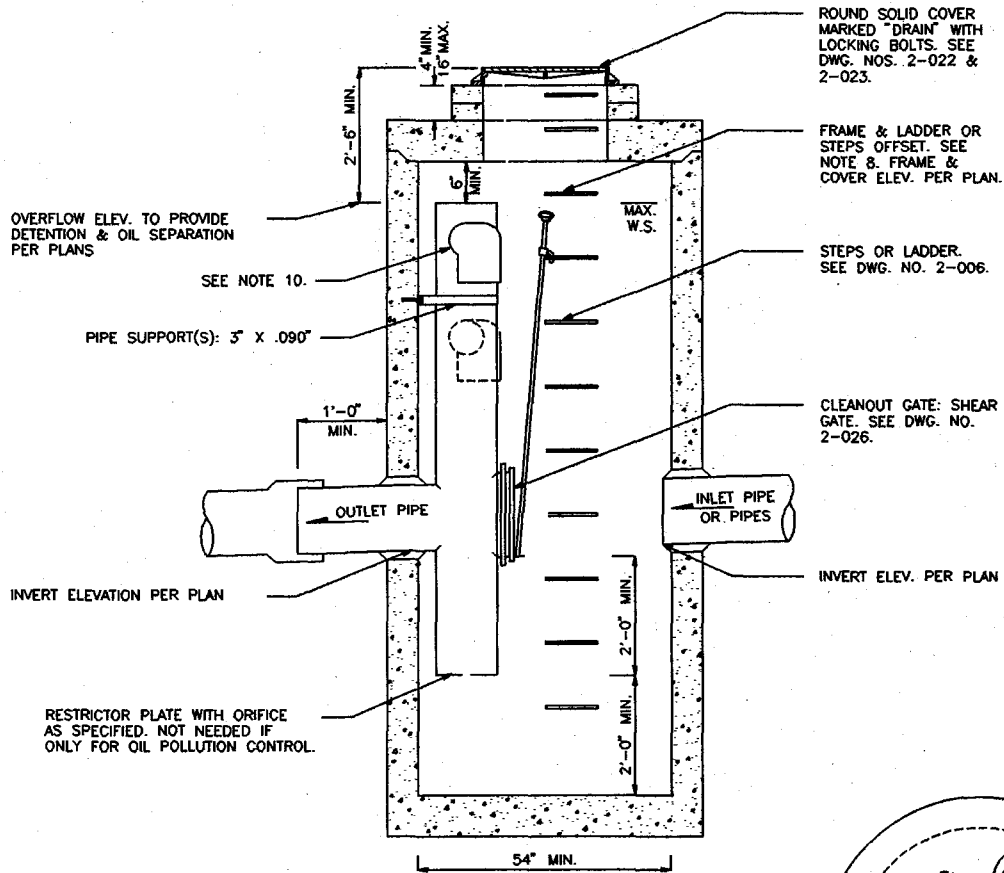

CATCH BASIN TYPE 2
DIAM. AS REQUIRED
SEE DWG. NO. 2-005.

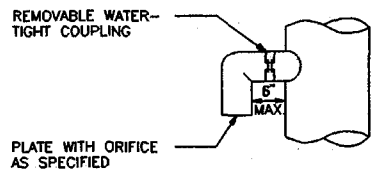

ELBOW DETAIL

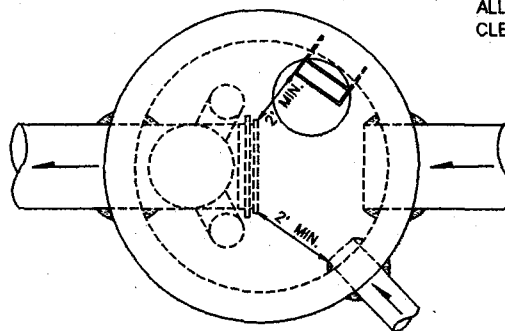

PLAN

DATE	REVISION	BY	APPR'D

NOTES:

1. PIPE SIZES AND SLOPES: PER PLANS.
2. OUTLET CAPACITY: NOT LESS THAN COMBINED INLETS.
3. EXCEPT AS SHOWN OR NOTED, UNITS SHALL BE CONSTRUCTED IN ACCORDANCE WITH THE REQUIREMENTS FOR CATCH BASIN TYPE 2, 54" MIN. DIAM.
4. PIPE SUPPORTS AND RESTRICTOR/SEPARATOR SHALL BE OF SAME MATERIAL, AND BE ANCHORED AT 3' MAX. SPACING BY 5/8" DIAM. STAINLESS STEEL EXPANSION BOLTS OR EMBEDDED 2" IN WALL.
5. THE RESTRICTOR/SEPARATOR SHALL BE FABRICATED FROM .060" ALUMINUM, OR .064" ALUMINIZED STEEL, OR .064" GALVANIZED STEEL PIPE; IN ACCORDANCE WITH AASHTO M 36, M 196, M 197 AND M 274. GALVANIZED STEEL SHALL HAVE TREATMENT 1.
6. OUTLET SHALL BE CONNECTED TO CULVERT OR SEWER PIPE WITH A STANDARD COUPLING BAND FOR CORRUGATED METAL PIPE, OR GROUTED INTO THE BELL OF CONCRETE PIPE.
7. THE VERTICAL RISER STEM OF THE RESTRICTOR/SEPARATOR SHALL BE THE SAME DIAM. AS THE HORIZONTAL OUTLET PIPE, WITH AN 8" MIN. DIAM.
8. FRAME AND LADDER OR STEPS OFFSET SO THAT:
 - A. CLEANOUT GATE IS VISIBLE FROM TOP.
 - B. CLIMB DOWN SPACE IS CLEAR OF RISER AND CLEANOUT GATE.
 - C. FRAME IS CLEAR OF CURB.
9. IF METAL OUTLET PIPE CONNECTS TO CEMENT CONCRETE PIPE: OUTLET PIPE TO HAVE SMOOTH O.D. EQUAL TO CONCRETE PIPE I.D. LESS 1/4".
10. MULTI-ORIFICE ELBOWS MAY BE LOCATED AS SHOWN OR ALL ON ONE SIDE OF RISER TO ASSURE LADDER CLEARANCE.



KING COUNTY PUBLIC WORKS
KING COUNTY, WASHINGTON

**FLOW RESTRICTOR / OIL POLLUTION
CONTROL DEVICE, TEE TYPE (FROP-T)**

**DWG. 2-025
NO.**

SIX EVENLY SPACED HOLES ON 10 3/8" BOLT CIRCLE FOR BOLTING TO FLANGE CONNECTION.

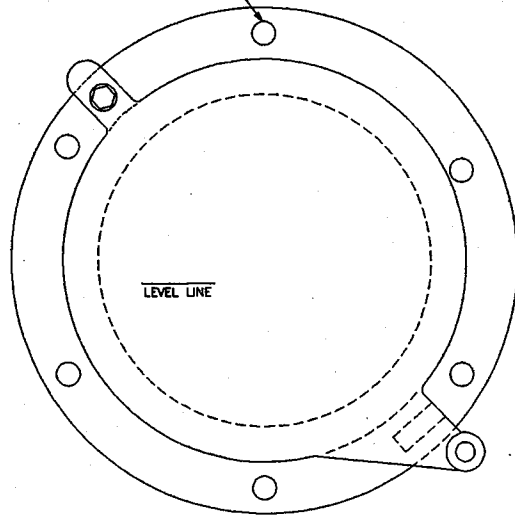

FRONT

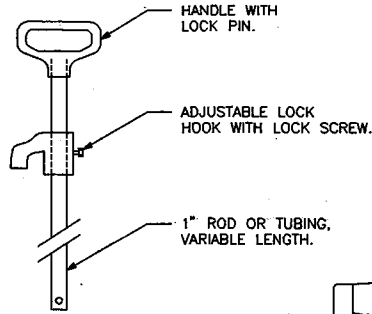

LIFT HANDLE

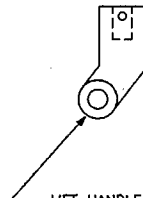

LIFT HANDLE SHALL BE ATTACHED PER MANUFACTURER'S RECOMMENDATIONS.

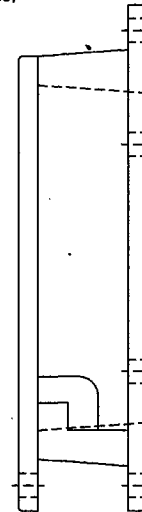

SIDE

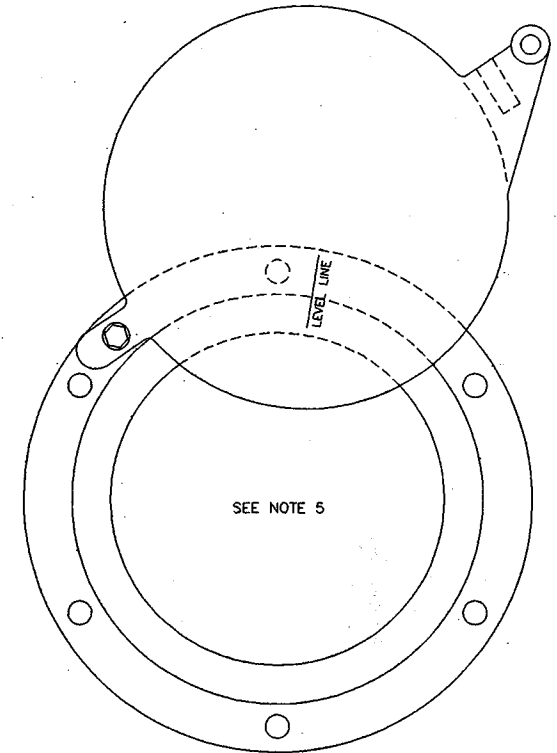

MAXIMUM OPENING OF GATE

NOTES:

1. SHEAR GATE SHALL BE ALUMINUM ALLOY PER ASTM B-26-ZG-32a OR CAST IRON ASTM A48 CLASS 30B AS REQUIRED.
2. GATE SHALL BE 8" DIAM. UNLESS OTHERWISE SPECIFIED.
3. GATE SHALL BE JOINED TO TEE SECTION BY BOLTING (THROUGH FLANGE), WELDING, OR OTHER SECURE MEANS.
4. LIFT ROD: AS SPECIFIED BY MFR. WITH HANDLE EXTENDING TO WITHIN ONE FOOT OF COVER AND ADJUSTABLE HOOK LOCK FASTENED TO FRAME OR UPPER HANDHOLD.
5. GATE SHALL NOT OPEN BEYOND THE CLEAR OPENING BY LIMITED HINGE MOVEMENT, STOP TAB, OR SOME OTHER DEVICE.
6. NEOPRENE RUBBER GASKET REQUIRED BETWEEN RISER MOUNTING FLANGE AND GATE FLANGE.
7. MATING SURFACES OF LID AND BODY TO BE MACHINED FOR PROPER FIT.
8. FLANGE MOUNTING BOLTS SHALL BE 3/8" DIAM. STAINLESS STEEL.
9. ALTERNATE CLEANOUT/SHEAR GATES TO THE DESIGN SHOWN ARE ACCEPTABLE, PROVIDED THEY MEET THE MATERIAL SPECIFICATIONS ABOVE AND HAVE A SIX BOLT, 10 3/8" BOLT CIRCLE FOR BOLTING TO THE FLANGE CONNECTION.

DATE	REVISION	BY	APPR'D



KING COUNTY PUBLIC WORKS
KING COUNTY, WASHINGTON

FROP-T SHEAR GATE DETAIL

DWG. NO. 2-026

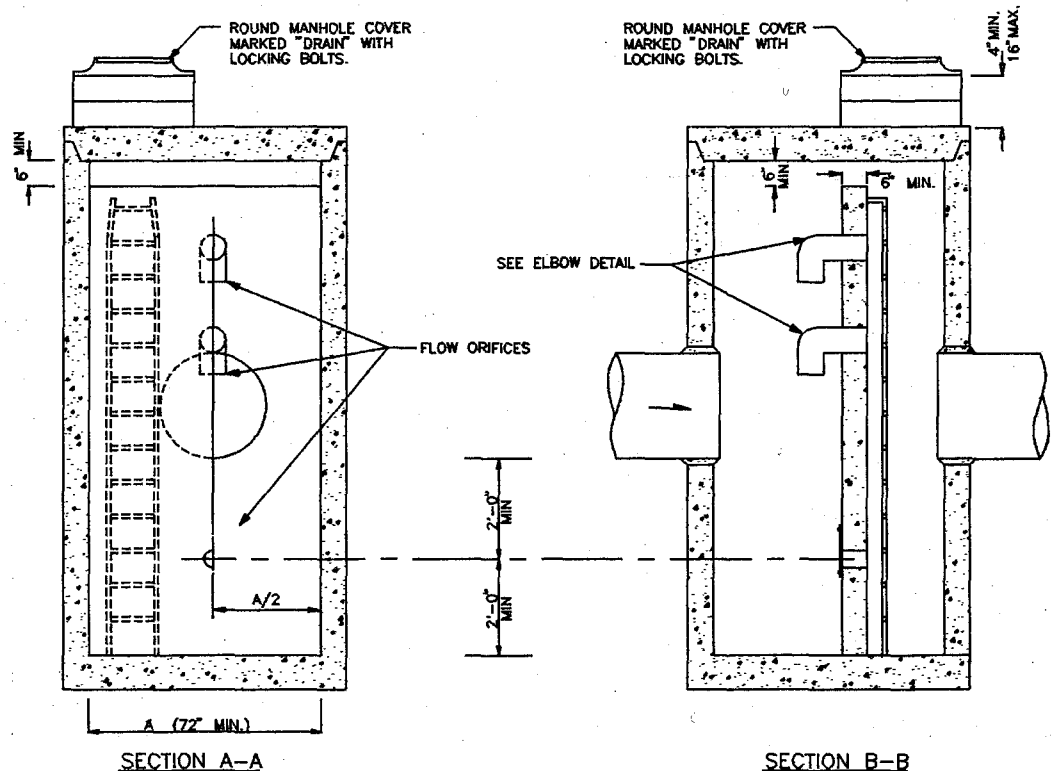

ELEVATION

- NOTES:
1. PIPE SIZE, SLOPES AND ALL ELEVATIONS: PER PLANS.
 2. OUTLET CAPACITY: NOT LESS THAN COMBINED INLETS.
 3. CATCH BASIN: TYPE 2, TO BE CONSTRUCTED IN ACCORDANCE WITH DWG. NO. 2-005 AND AASHTO M199 UNLESS OTHERWISE SPECIFIED.
 4. COVERS: ROUND, SOLID MARKED "DRAIN," WITH LOCKING BOLTS SEE DWG. NO. 2-022 & 2-023.
 5. ORIFICES: SIZED AND LOCATED AS REQUIRED, WITH LOWEST ORIFICE MIN. 2' FROM BASE.
 6. BAFFLE WALL SHALL HAVE #4 BAR AT 12" SPACING EACH WAY.
 7. PRECAST BAFFLE WALL SHALL BE KEYED AND GROUTED IN PLACE.
 8. BOTTOM ORIFICE PLATE TO BE 1/4" MIN. GALVANIZED STEEL AND ATTACHED WITH 1/2" STAINLESS STEEL BOLTS. OMIT ORIFICE PLATE IF ONLY FOR OIL SEPARATION.
 9. UPPER FLOW ORIFICE SHALL BE ALUMINUM, ALUMINIZED STEEL OR GALVANIZED STEEL. SEE DWG. NO. 2-025. GALVANIZED STEEL SHALL HAVE TREATMENT 1.

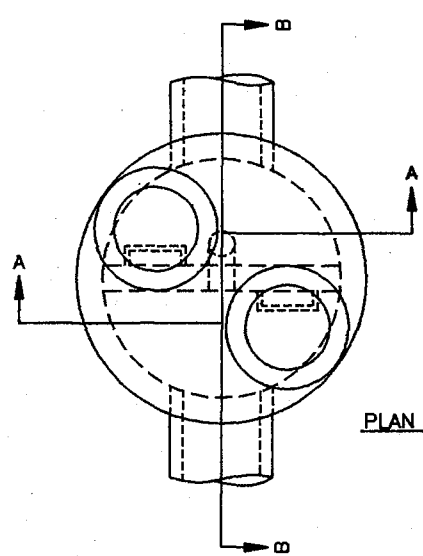

PLAN

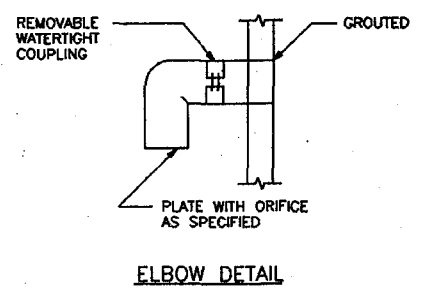

ELBOW DETAIL

DATE	REVISION	BY	APPR'D



KING COUNTY PUBLIC WORKS
KING COUNTY, WASHINGTON

FLOW RESTRICTOR / OIL POLLUTION
CONTROL DEVICE, BAFFLE TYPE (FROP-B)

DWG. NO. 2-027

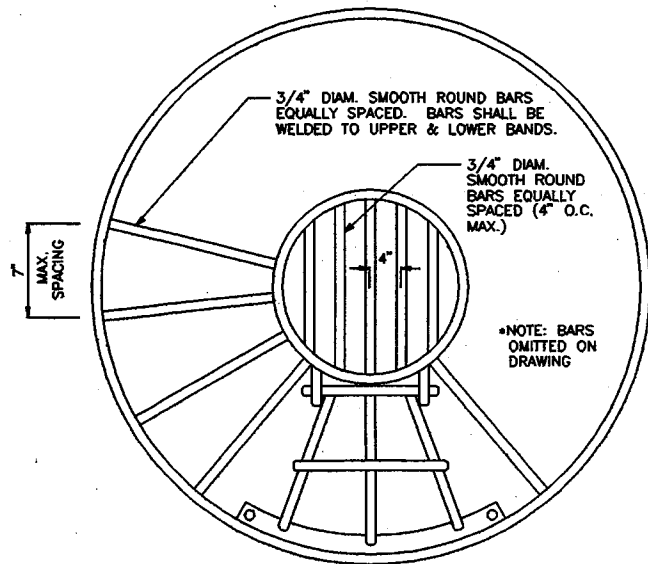

PLAN

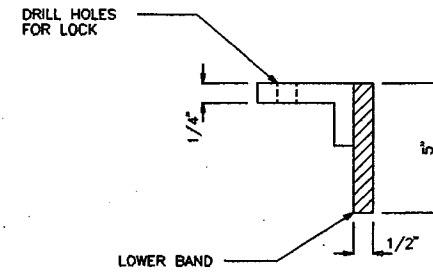
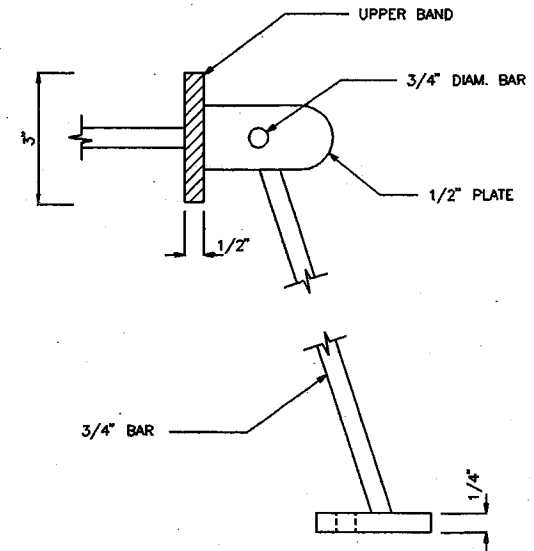

ENTRY GATE DETAIL

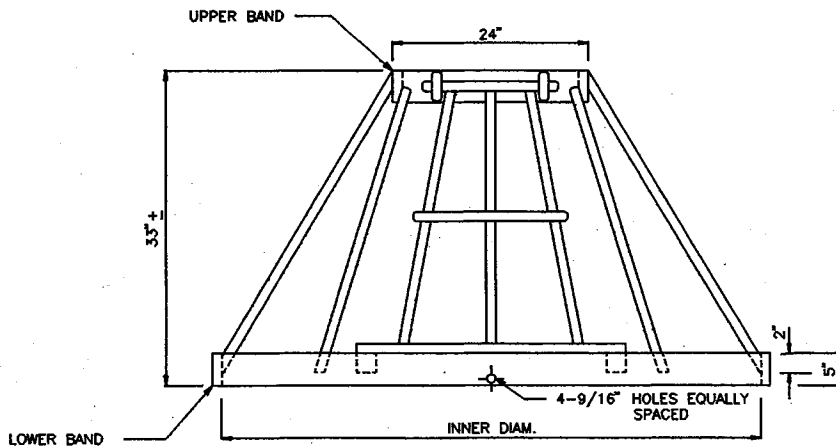

ELEVATION

CB	INNER DIAM.
48"	58"
54"	65"
60"	72"
72"	86"
96"	114"

NOTES:

1. ALL STEEL IN PLATES, BARS AND BANDS SHALL CONFORM TO THE REQUIREMENTS OF ASTM A36.
2. DEBRIS CAGE SHALL BE HOT-DIP GALVANIZED IN ACCORDANCE WITH ASTM A123 (AASHTO M111).

DATE	REVISION	BY	APPR'D



KING COUNTY PUBLIC WORKS
KING COUNTY, WASHINGTON

DEBRIS CAGE

DWG. NO. 2-028

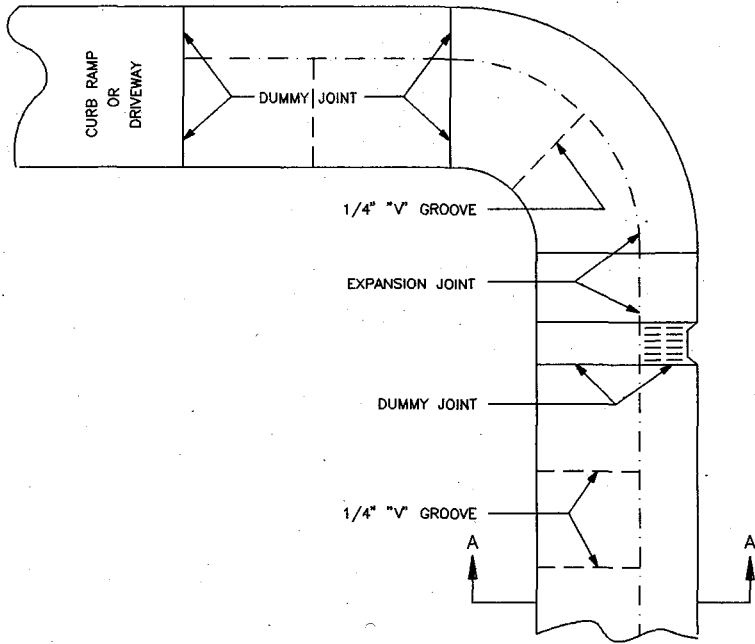

ROLLED CURB & SIDEWALK

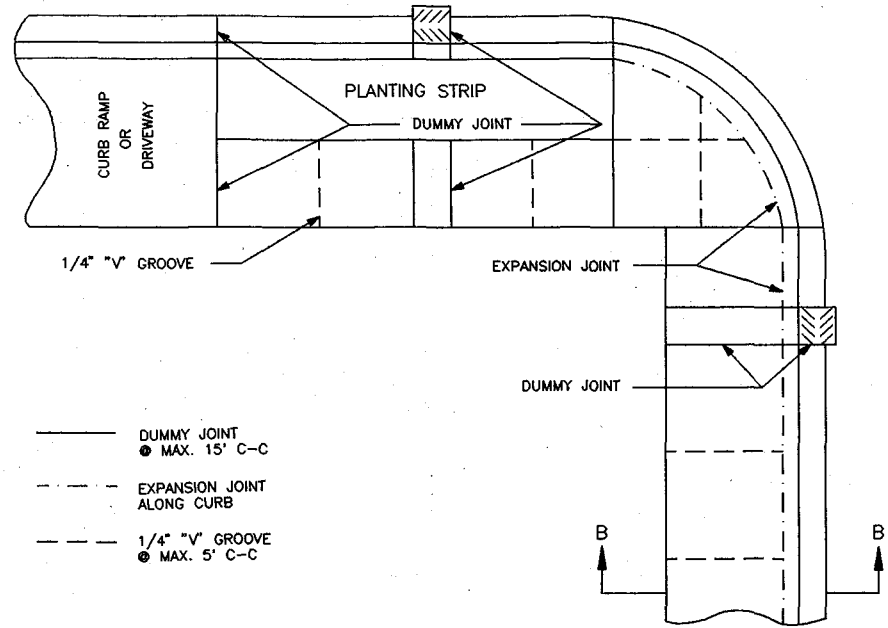

VERTICAL CURB & SIDEWALK

——— DUMMY JOINT
 ● MAX. 15' C-C
 - - - EXPANSION JOINT
 ALONG CURB
 - - - 1/4" "V" GROOVE
 ● MAX. 5' C-C

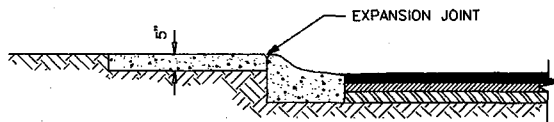

SECTION A-A

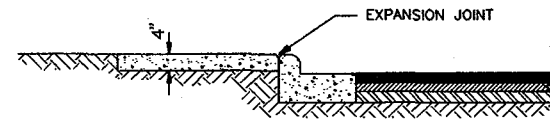

SECTION B-B

NOTE:

1. SEE SEC. 3.04 FOR JOINT REQUIREMENTS.
2. FOR INTEGRAL POUR CONSTRUCTION, 1/4" EDGED GROOVE MAY REPLACE EXPANSION JOINT AT INTERFACE BETWEEN CURB AND ADJACENT SIDEWALK.

DATE	REVISION	BY	APPR'D



KING COUNTY PUBLIC WORKS
KING COUNTY, WASHINGTON

CURB & SIDEWALK JOINTS

DWG. NO. 3-001

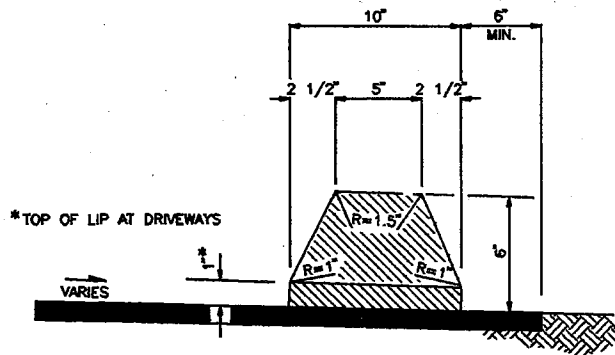

EXTRUDED ASPHALT OR CEMENT
CONCRETE CURB 3.5

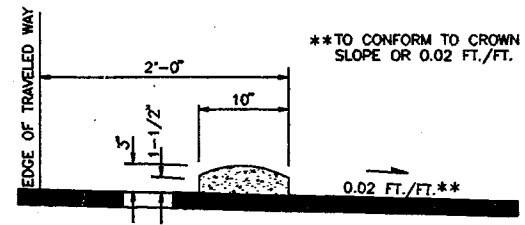

MOUNTABLE CEMENT CONCRETE CURB

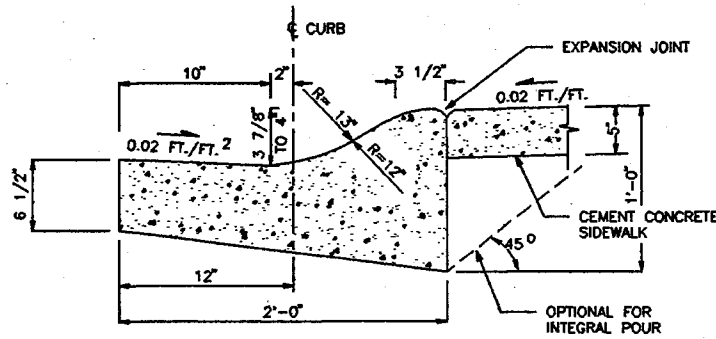

CEMENT CONCRETE ROLLED CURB

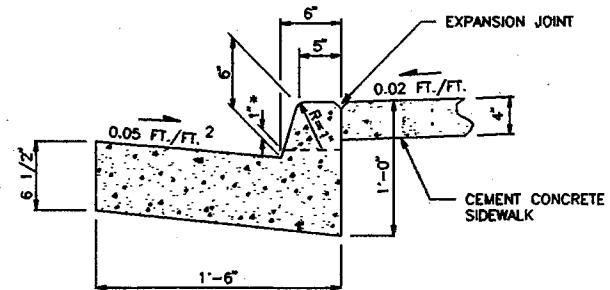

* NOTE: TOP OF LIP AT DRIVEWAYS.

CEMENT CONCRETE CURB & GUTTER

NOTES:

1. SEE SEC. 3.04 K.C.R.S. FOR JOINT REQUIREMENTS.
2. ROLL GUTTER TO MATCH POSITIVE SUPERELEVATION.
3. SEE DRAWING NO. 1-006 FOR CONFIGURATION OF FILL & WALKWAY BEHIND CURB IF REQUIRED.
4. FOR INTEGRAL POUR CONSTRUCTION, 1/4" EDGED GROOVE MAY REPLACE EXPANSION JOINT AT INTERFACE BETWEEN THE CURB AND ADJACENT SIDEWALK.
5. SEE SEC. 3.03 FOR EXTRUDED CURB ANCHORAGE.

DATE	REVISION	BY	APPR'D



KING COUNTY PUBLIC WORKS
KING COUNTY, WASHINGTON

CURB DETAILS

DWG. 3-002
NO.

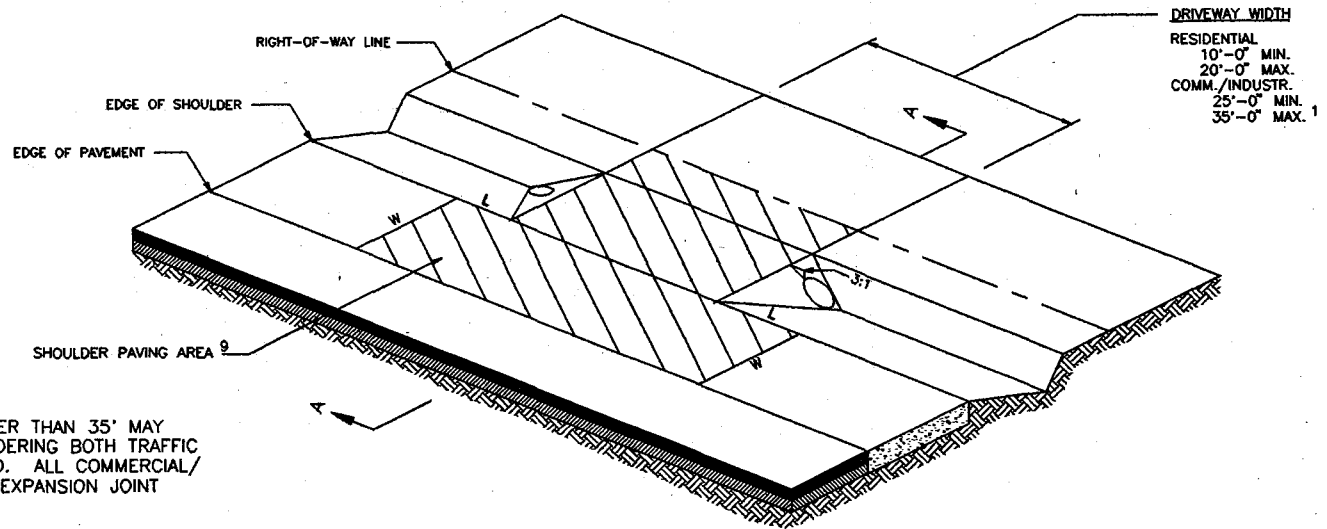

NOTES:

1. COMMERCIAL/INDUSTRIAL DRIVEWAYS WIDER THAN 35' MAY BE APPROVED BY THE ENGINEER CONSIDERING BOTH TRAFFIC SAFETY AND THE ACTIVITY BEING SERVED. ALL COMMERCIAL/INDUSTRIAL DRIVEWAYS SHALL HAVE AN EXPANSION JOINT LOCATED MID-WIDTH. SEE SEC. 3.04.
2. PIPE SHALL BE:
 - A. SIZED TO CONVEY COMPUTED STORM WATER RUNOFF, AND
 - B. MIN. 12" DIAM., AND
 - C. EQUAL TO OR LARGER THAN EXISTING PIPES WITHIN 500' UPSTREAM.
3. EXPOSED PIPE ENDS SHALL BE BEVELED TO MATCH THE SLOPE FACE AND PROJECT NO MORE THAN 2" BEYOND SLOPE SURFACE. PROJECTING HEADWALLS ARE NOT ACCEPTABLE.
4. CONCRETE PIPE SHALL HAVE MIN. COVER OF 6" TO FINISH GRADE. ALL OTHER TYPES OF PIPE SHALL HAVE MIN. 12" COVER.
5. PIPE SHALL BE INSTALLED IN A STRAIGHT UNIFORM ALIGNMENT AT A MIN. 0.5% SLOPE (0.5 FT. PER 100 FT.) WITH THE DOWNSTREAM END LOWER THAN THE UPSTREAM END.
6. PIPE MAY BE OMITTED IF ROADSIDE DITCH DOES NOT EXIST AND DRIVEWAY DOES NOT BLOCK NATURAL FLOW.
7. DRIVEWAY SLOPE SHALL MATCH TO BACK EDGE OF SHOULDER, BUT SHOULDER SLOPE AND EDGE OF SHOULDER SHALL NOT BE ALTERED AS A RESULT OF DRIVEWAY CONSTRUCTION.
8. PAVED DRIVEWAYS SHALL BE PAVED THROUGH RIGHT-OF-WAY WITH A.C. OR B.S.T., BUT NOT P.C.C.
9. GRAVEL DRIVEWAYS SHALL BE PAVED BETWEEN THE EDGE OF PAVEMENT AND R/W WITH A.C. OR B.S.T. ONLY WITH DIMENSIONS L=W.
10. SEE SEC. 3.01 AND 4.01.

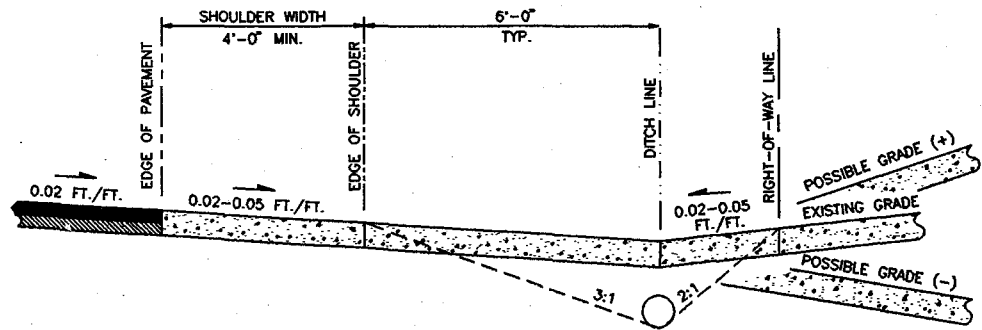

KING COUNTY PUBLIC WORKS
 KING COUNTY, WASHINGTON

SHOULDER & DITCH SECTION DRIVEWAY

DWG. NO. 3-003

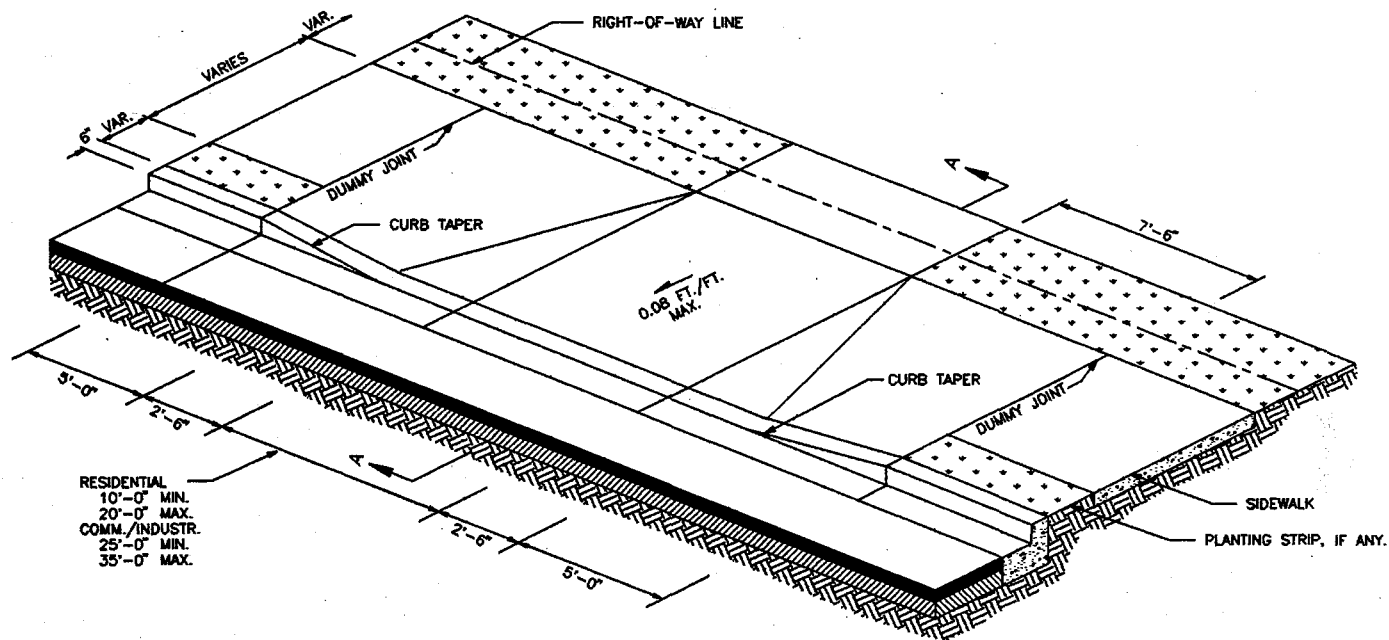

RESIDENTIAL
10'-0" MIN.
20'-0" MAX.
COMM./INDUSTR.
25'-0" MIN.
35'-0" MAX.

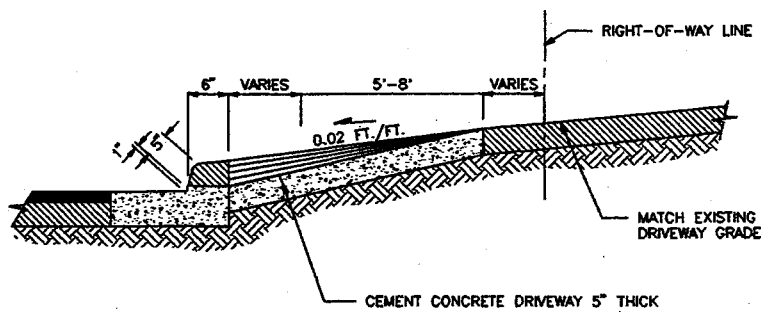

SECTION A-A

NOTES:

1. COMMERCIAL/INDUSTRIAL DRIVEWAYS WIDER THAN 35' MAY BE APPROVED BY THE ENGINEER CONSIDERING TRAFFIC SAFETY AND NEEDS OF THE ACTIVITY SERVED. ALL COMMERCIAL/INDUSTRIAL DRIVEWAYS SHALL HAVE AN EXPANSION JOINT LOCATED MID-WIDTH. SEE SEC. 3.04.
2. SEE SEC. 3.01.
3. SEE SEC. 4.01 FOR SURFACING REQUIREMENTS.

DATE	REVISION	BY	APPR'D



KING COUNTY PUBLIC WORKS
KING COUNTY, WASHINGTON

CURB & GUTTER SECTION DRIVEWAY

DWG. 3-004
NO.

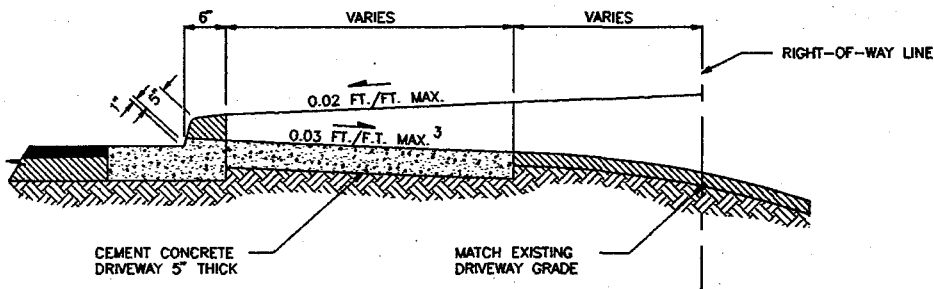
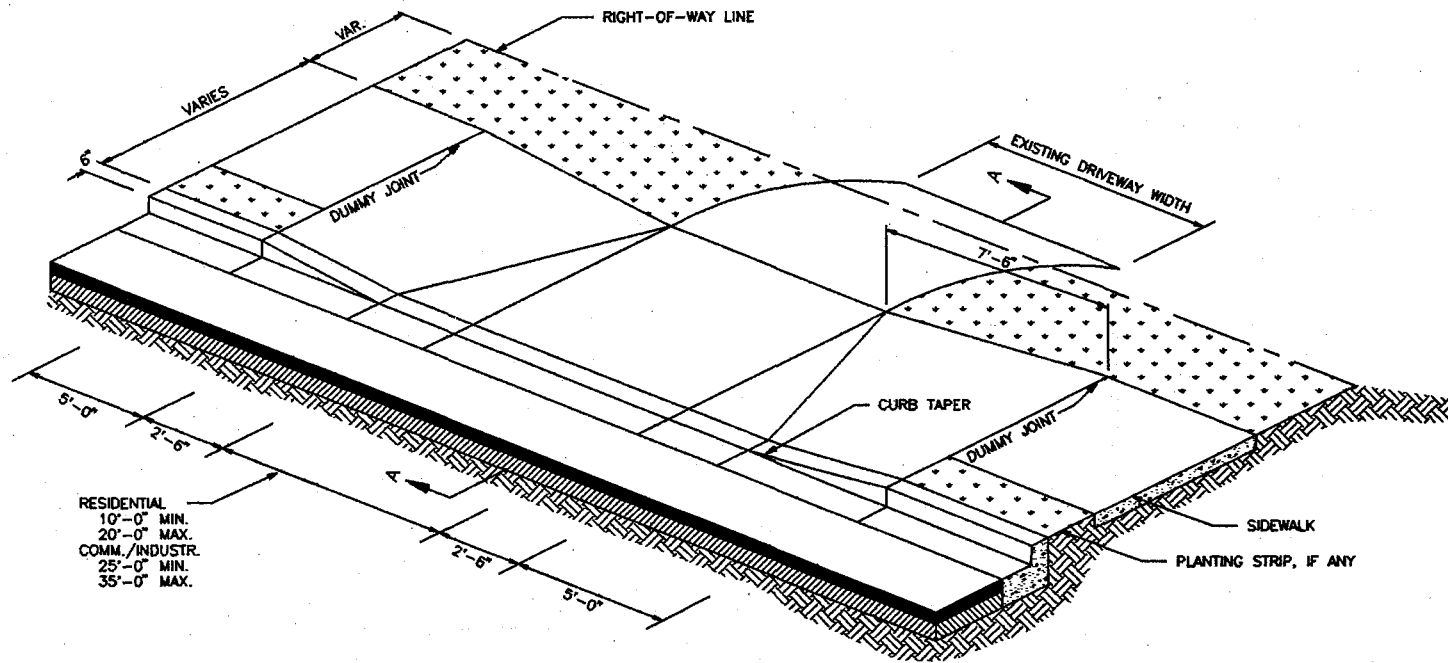

SECTION A-A

NOTES:

1. A REVERSE SLOPE DRIVEWAY IS SUBJECT TO APPROVAL BY ENGINEER CONSIDERING NEED FOR AND COMPATIBILITY OF THIS FEATURE.
2. COMMERCIAL/INDUSTRIAL DRIVEWAYS WIDER THAN 35' MAY BE APPROVED CONSIDERING TRAFFIC SAFETY AND NEEDS OF THE ACTIVITY SERVED. ALL COMMERCIAL/INDUSTRIAL DRIVEWAYS SHALL HAVE AN EXPANSION JOINT LOCATED MID-WIDTH. SEE SEC. 3.04.
3. A STORM SEWER INLET SHALL BE LOCATED WITHIN 20' BUT NO CLOSER THAN 10' UPGRADE FROM NEAREST EDGE OF CURB TAPER.
4. SEE SEC. 3.01.
5. SEE SEC. 4.01 FOR SURFACING REQUIREMENTS.

DATE	REVISION	BY	APPR'D



KING COUNTY PUBLIC WORKS
KING COUNTY, WASHINGTON

REVERSE SLOPE DRIVEWAY

DWG. 3-005
NO.

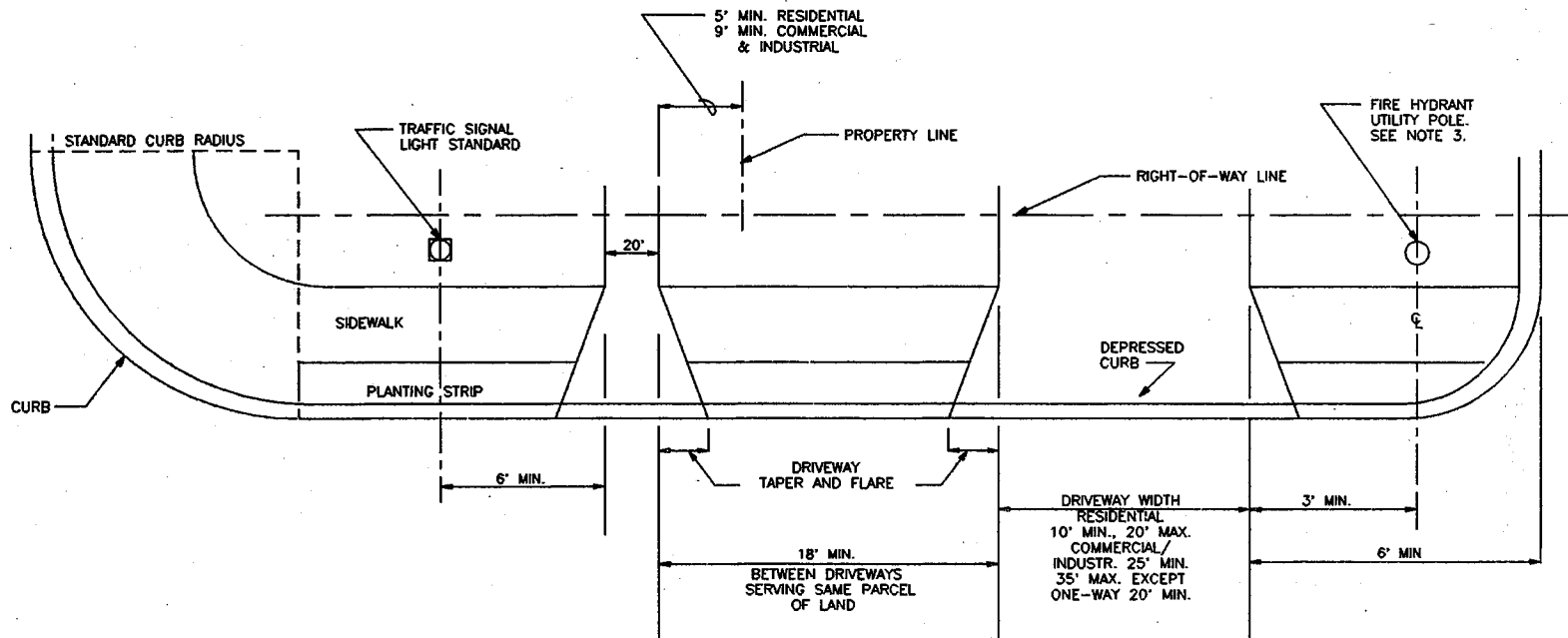

NOTES:

1. NO PORTION OF ANY DRIVEWAY SHALL ENCR OACH IN CURB RETURN.
2. COMMERCIAL/INDUSTRIAL DRIVEWAYS MUST BE APPROVED BY THE ENGINEER, CONSIDERING BOTH TRAFFIC SAFETY AND THE ACTIVITY BEING SERVED. ALL COMMERCIAL/INDUSTRIAL DRIVEWAYS SHALL HAVE AN EXPANSION JOINT LOCATED MID-WIDTH. SEE SEC. 3.04.
3. FOR ROADWAY CLEARANCE OF UTILITY POLES AND STRUCTURES SEE SEC. 8.02G AND DWG. NO. 5-001.
4. DRIVEWAYS SHALL BE LOCATED AS FAR FROM THE INTERSECTION AS POSSIBLE.

DATE	REVISION	BY	APPR'D



KING COUNTY PUBLIC WORKS
KING COUNTY, WASHINGTON

LOCATION & WIDTH OF NEW DRIVEWAYS

DWG. NO. 3-006

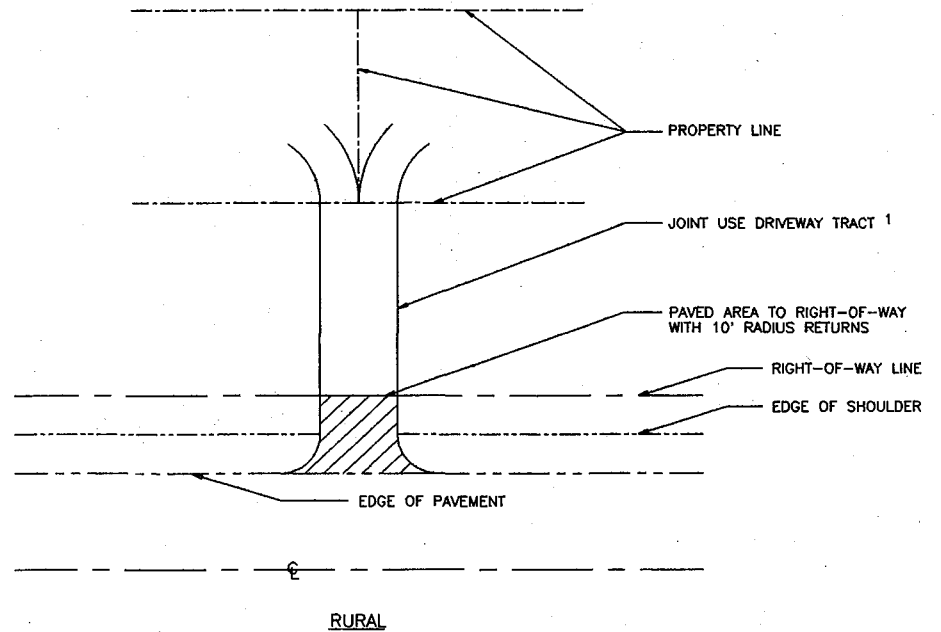
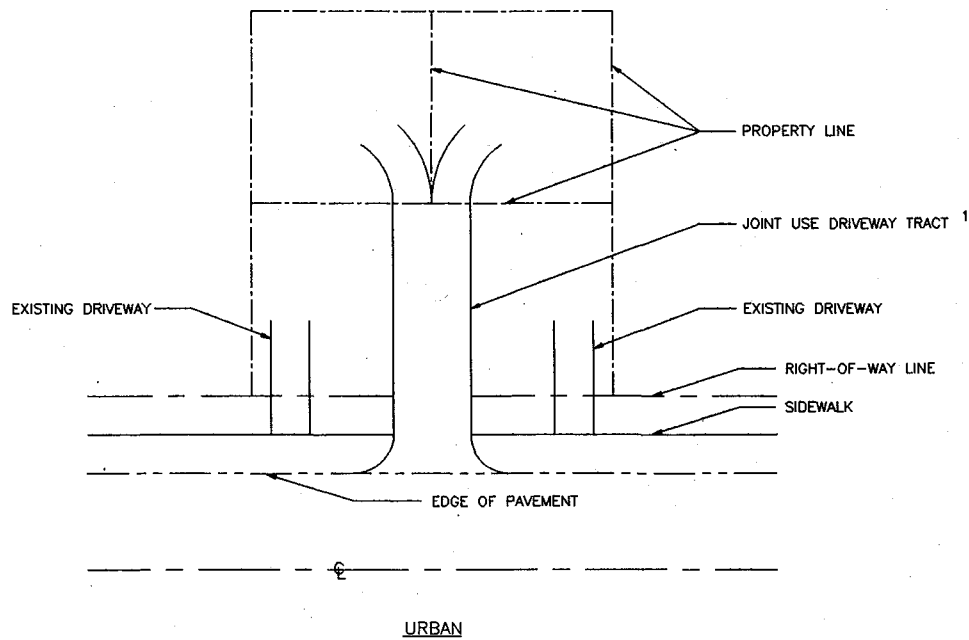

NOTE:

1. SEE SEC. 3.01 FOR TRACT WIDTH AND PAVING REQUIREMENTS.

DATE	REVISION	BY	APPR'D



KING COUNTY PUBLIC WORKS
KING COUNTY, WASHINGTON

JOINT USE DRIVEWAY TRACT

DWG. 3-007
NO.

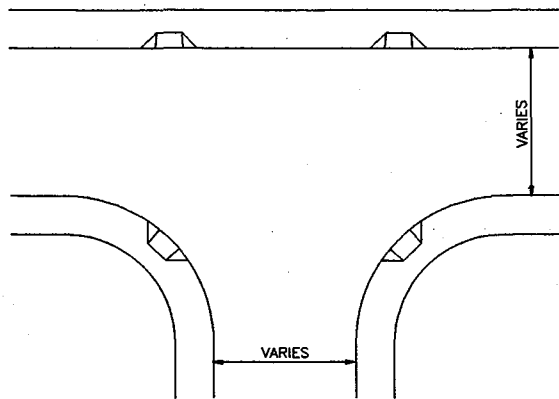

RAMP LOCATIONS
ON RESIDENTIAL ACCESS STREETS

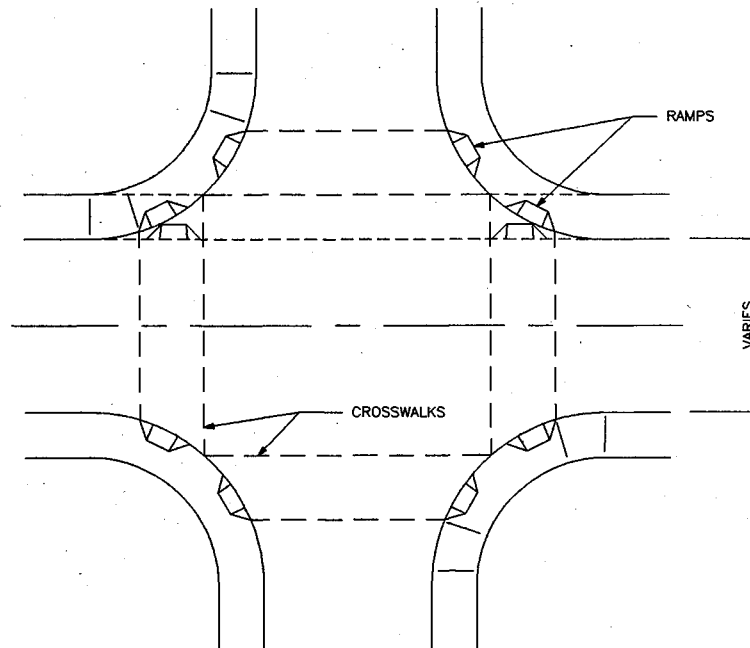
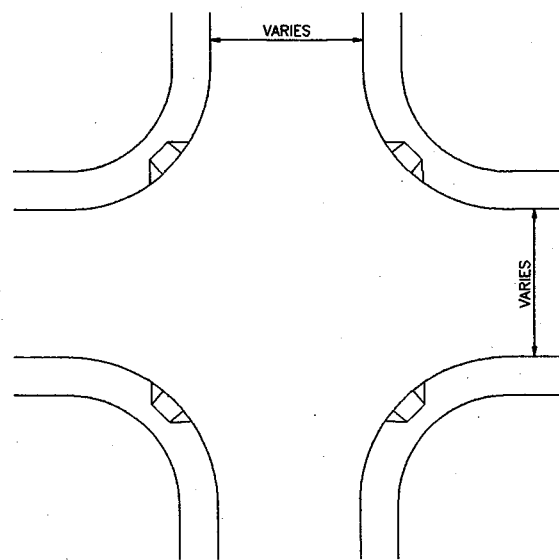

RAMP LOCATIONS
ON ARTERIALS AND COMMERCIAL
ACCESS STREETS

NOTES:

1. CATCH BASIN AND INLETS SHALL BE OUTSIDE THE CURB RAMP (24" MIN. CLEARANCE FROM RAMP). SEE SEC. 7.05 FOR CROSSWALK RESTRICTIONS.
2. CARE SHALL BE TAKEN TO KEEP THE RAMP FROM CONFLICTING WITH HYDRANTS, POLES, INLETS, AND OTHER UTILITIES.
3. CONSTRUCT RAMP IN ACCORDANCE WITH DWG. NO. 4-002 OR DWG. NO. 4-003.
4. CROSSWALKS ARE NOT ALWAYS MARKED.
5. WHEN RAMPS ARE CONSTRUCTED ON ONE SIDE OF STREET, RAMPS SHALL BE CONSTRUCTED AT CORRESPONDING LOCATIONS ON OPPOSITE SIDE OF STREET.

DATE	REVISION	BY	APPR'D



KING COUNTY PUBLIC WORKS
KING COUNTY, WASHINGTON

CURB RAMP LOCATIONS

DWG. NO. 4-001

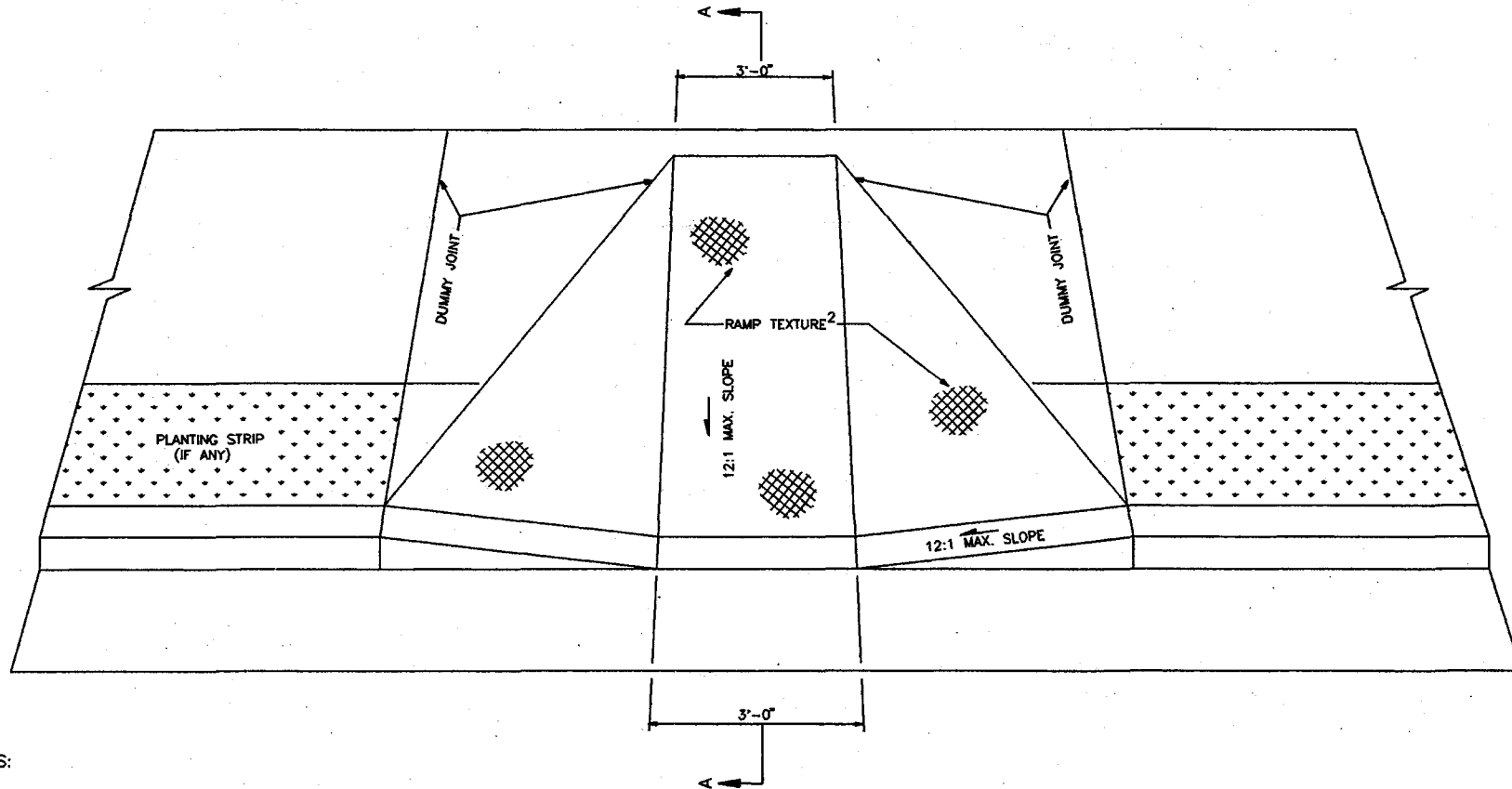

NOTES:

1. RAMP AND APPROACHES SHALL BE CLEAR OF OBSTACLES INCL. HYDRANTS, POLES, AND INLETS.
2. RAMP SHALL BE TEXTURED BY IMPRINT OF METAL GRID WITH 1/2" SPACING.
3. RAMP CENTER LINE SHALL BE PERPENDICULAR TO OR RADIAL TO CURB RETURNS UNLESS OTHERWISE APPROVED BY ENGINEER.
4. WHEN RAMPS ARE CONSTRUCTED ON ONE SIDE OF THE STREET, RAMPS SHALL BE CONSTRUCTED AT CORRESPONDING SIDEWALK LOCATIONS ON OPPOSITE SIDE OF STREET. SEE DWG. NO. 4-001.
5. ON ARTERIAL STREETS, IN GENERAL CASE, CURB RAMPS SHALL BE CONSTRUCTED TWO PER RADIUS, IN OR PREFERABLY ADJACENT TO THE MAIN PEDESTRIAN PATHS.
6. ON RESIDENTIAL STREETS OR WHERE UTILITIES ARE IN CONFLICT OR STREET GRADE EXCEEDS 4.0% CURB RAMPS MAY BE CONSTRUCTED ONE PER RADIUS, AT MIDPOINT OF CURB RETURN OR AT MAIN PEDESTRIAN PATH.
7. SEE SEC. 3.02 AND 3.05.

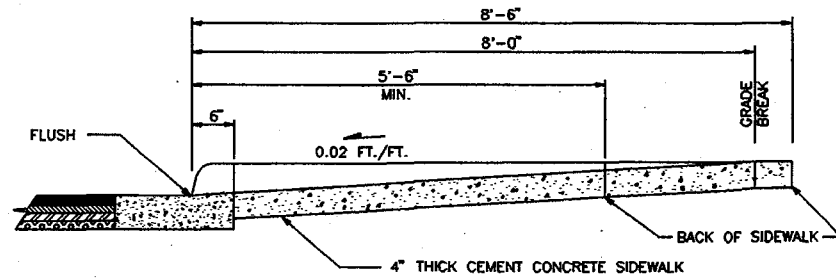

SECTION A-A



KING COUNTY PUBLIC WORKS
KING COUNTY, WASHINGTON

CURB RAMPS IN VERTICAL CURB

DWG. 4-002
NO.

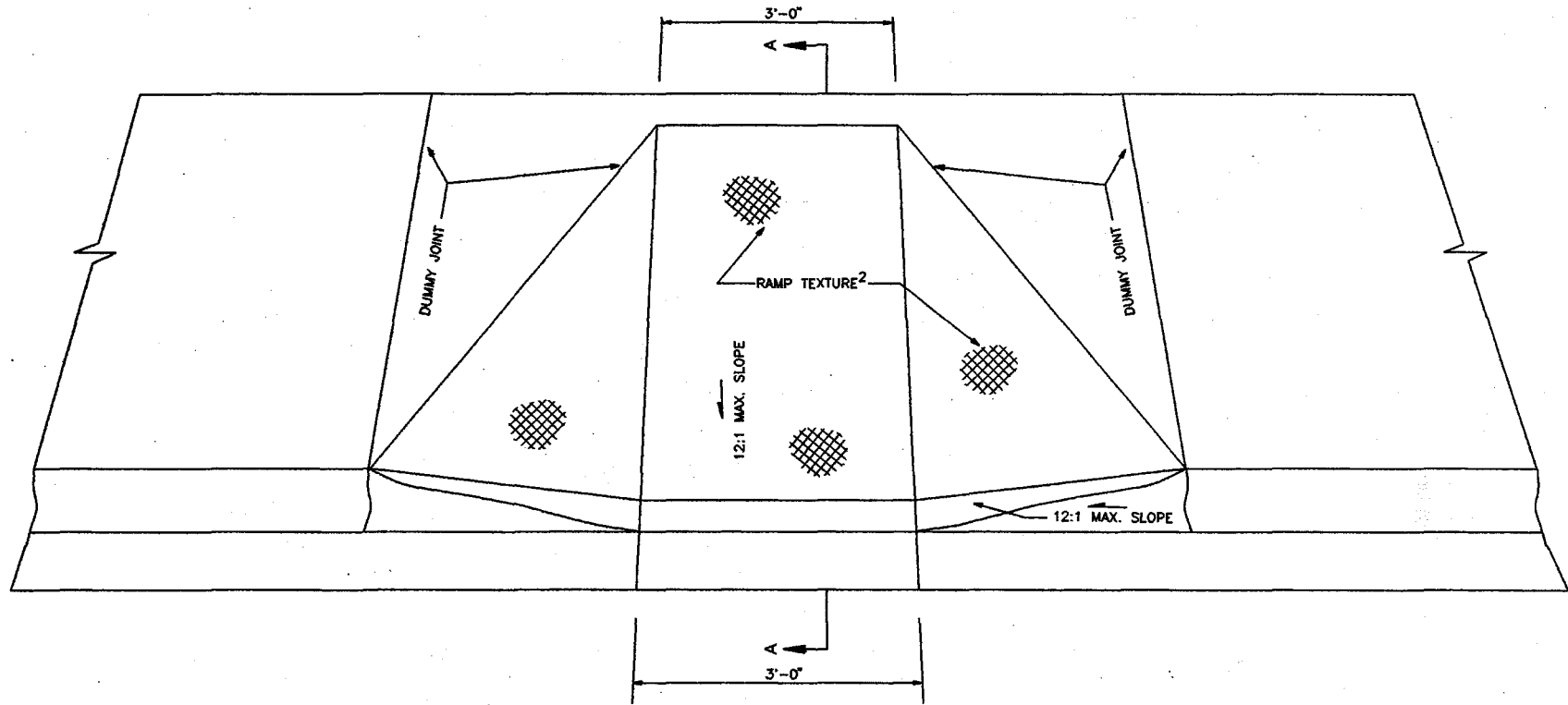

NOTES:

1. RAMP AND APPROACHES SHALL BE CLEAR OF OBSTACLES INCL. HYDRANTS, POLES, AND INLETS.
2. RAMP SHALL BE TEXTURED BY IMPRINT OF METAL GRID WITH 1/2" SPACING.
3. RAMP CENTER LINE SHALL BE PERPENDICULAR TO OR RADIAL TO CURB RETURNS UNLESS OTHERWISE APPROVED BY ENGINEER.
4. WHEN RAMPS ARE CONSTRUCTED ON ONE SIDE OF THE STREET, RAMPS SHALL BE CONSTRUCTED AT CORRESPONDING SIDEWALK LOCATIONS ON OPPOSITE SIDE OF STREET. SEE DWG. NO. 4-001.
5. SEE SEC. 3.05.

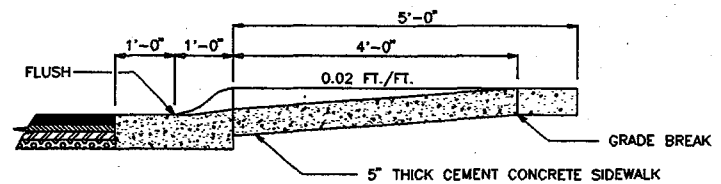

SECTION A-A



KING COUNTY PUBLIC WORKS
KING COUNTY, WASHINGTON

CURB RAMPS IN ROLLED CURB

DWG. 4-003
NO.

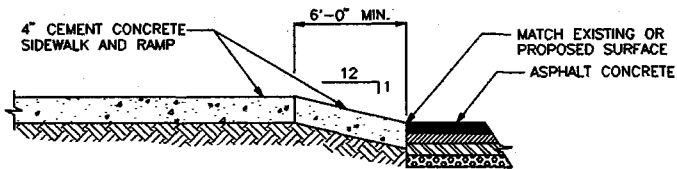
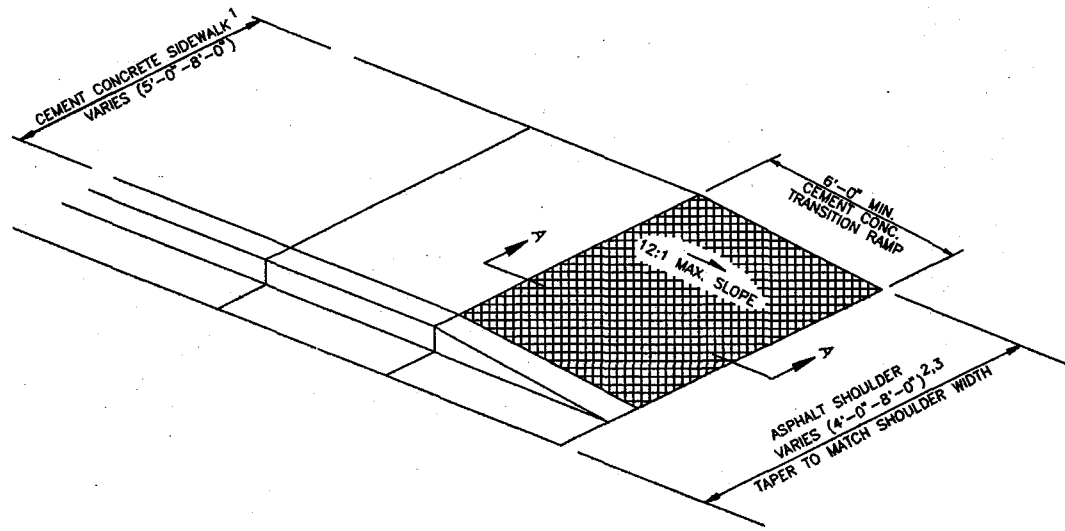

SECTION A-A

NOTES:

1. FOR WIDTHS OF SIDEWALK SEE SEC. 3.02.
2. FOR WIDTHS OF PAVEMENT AND SHOULDER SEE SECS. 2.02, 2.03, AND 2.04.
3. SHOULDER SHALL BE SURFACED AS REQUIRED BY SECTIONS 3.07 AND 4.01. IF PAVED, SHOULDER SLOPE SHALL MATCH CROWN SLOPE OR .02 FT./FT.
4. FOR CURB AND SIDEWALK JOINTS SEE DWG. NO. 3-001.
5. TRANSITION RAMP SHALL BE TEXTURED BY IMPRINT OF METAL GRID WITH 1/2" SPACING.



KING COUNTY PUBLIC WORKS
KING COUNTY, WASHINGTON

CEMENT CONCRETE SIDEWALK
TRANSITION TO ASPHALT SHOULDER

DWG. 4-004
NO.

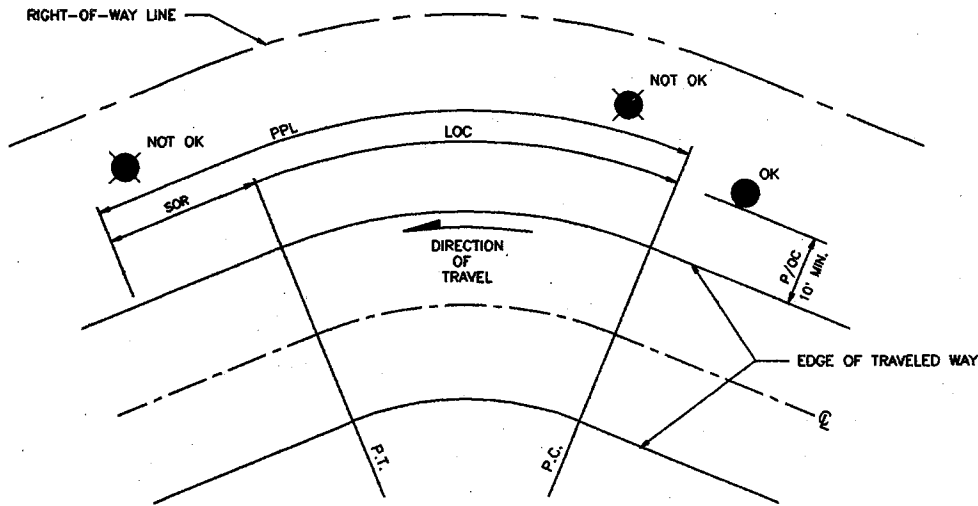

**OUTSIDE OF CURVE
POSTED 40 MPH & OVER**

- LOC: LENGTH OF CURVE (FEET) AT EDGE OF TRAVELED WAY FROM P.C. TO P.T.
- SOR: SAFETY OVERRUN (FEET) BEYOND P.T.
- PPL: PROHIBITED POLE LOCATION (FEET) (LOC + SOR) WHERE POLES OR OBSTACLES MUST BE REMOVED OR BARRICADED.

PPL (FEET) ON OUTSIDE OF CURVES WITH POSTED SPEED LIMIT OF 40 MPH & OVER.	
40 MPH	LOC + 220 (SOR)
45	LOC + 255
50	LOC + 290
55	LOC + 325

APPLIES TO ROADWAY WITH SHOULDER OR MOUNTABLE CURB ON OUTSIDE OF CURVE, WITH:
 -RADIUS LESS THAN 3500', AND
 -POSTED SPEED GREATER THAN OR EQUAL TO 40 M.P.H.

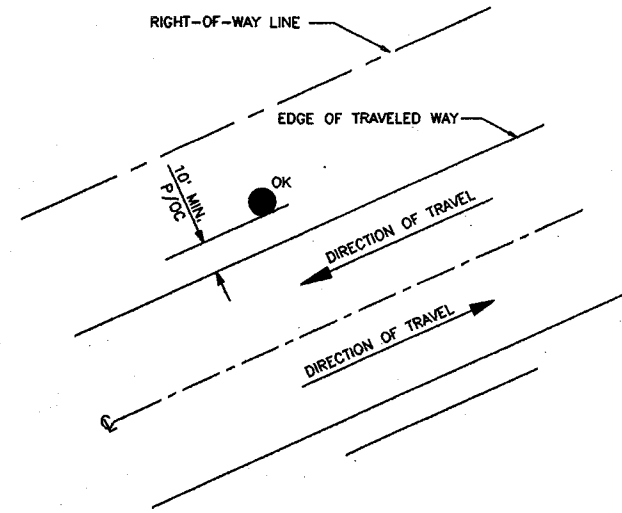

GENERAL CASE

P/O: POLE/OBSTACLE CLEARANCE TO NEAREST FACE OF POLE/OBSTACLE.

APPLIES: TO ROADWAY WITH SHOULDER OR MOUNTABLE CURB ON:

1. TANGENT, OR
2. INSIDE OF CURVE, OR
3. OUTSIDE OF CURVE, EITHER WITH
 -POSTED SPEED LESS THAN 40 MPH OR
 -RADIUS GREATER THAN 3500' ON ROADWAY MEETING ALL CURRENT DESIGN STANDARDS.

NOTES:

1. THE STANDARDS SHALL APPLY TO EVERY NEW PLACEMENT AND EVERY PLANNED, NON-EMERGENCY REPLACEMENT OF EXISTING POLES AND OTHER UTILITY STRUCTURES WITHIN KING COUNTY RIGHT-OF-WAY.
2. NO POLES MAY BE REPLACED ON THE OUTSIDE OF A CURVE WITH A POSTED SPEED LIMIT OF 40 MPH OR OVER UNLESS APPROVED THROUGH A VARIANCE REQUEST.
3. SEE SECS. 5.11 & 8.02G.



KING COUNTY PUBLIC WORKS
 KING COUNTY, WASHINGTON

**CLEARANCE OF ROADSIDE OBSTACLES
 ON SHOULDER TYPE ROAD**

DWG. 5-001
 NO.

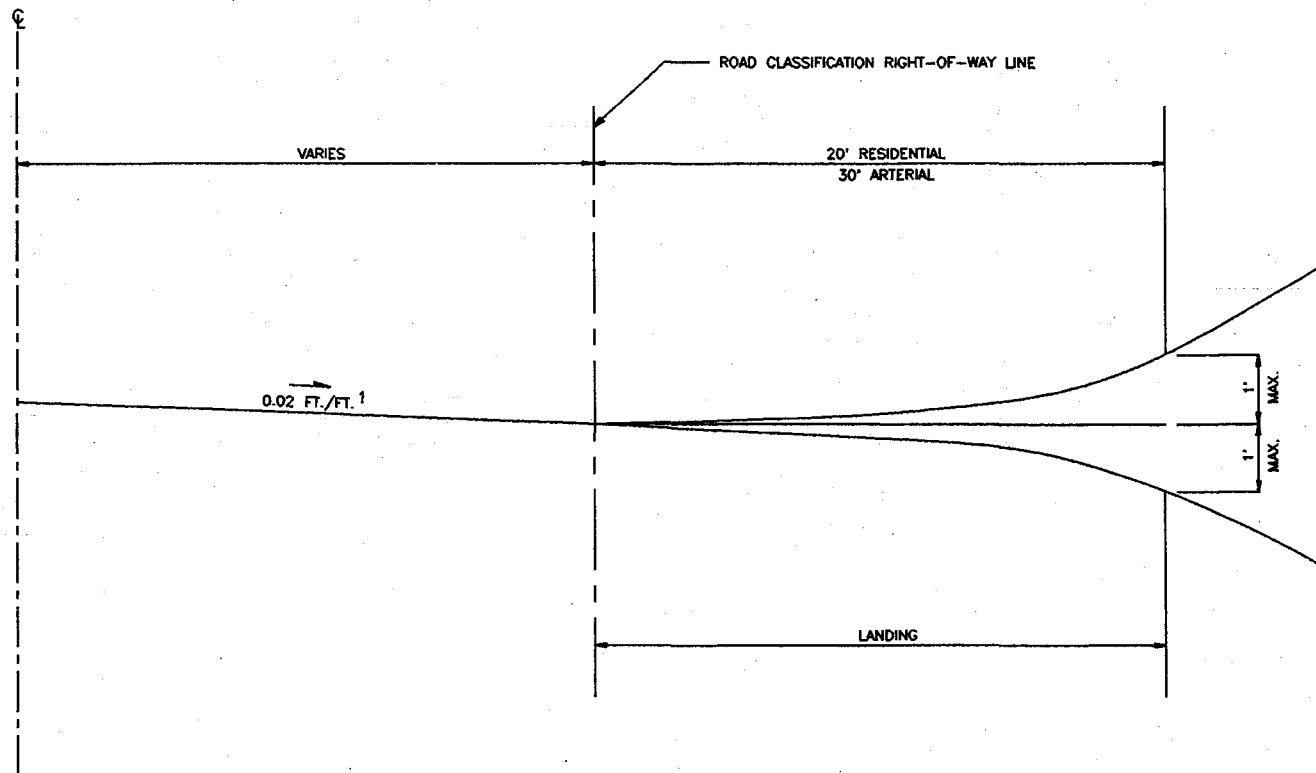

NOTES:

1. SEE SECS. 2.02, 2.03 OR 2.04 FOR SUPERELEVATION REQUIREMENTS.
2. SEE SEC. 2.10 FOR LANDING REQUIREMENTS.



KING COUNTY PUBLIC WORKS
KING COUNTY, WASHINGTON

INTERSECTION LANDING

DWG. 5-002
NO.

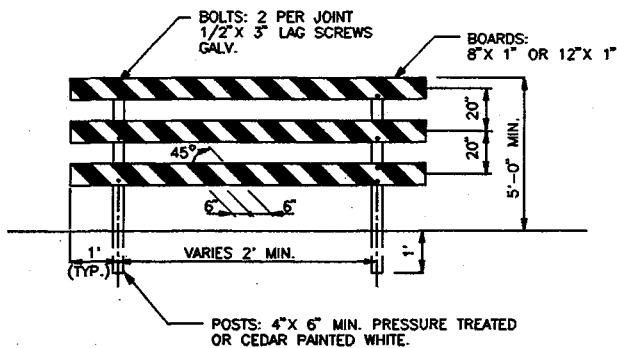

FIXED (PERMANENT)
TYPE III BARRICADE

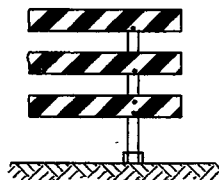
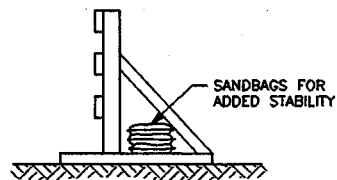

MOVABLE (TEMPORARY)
TYPE III BARRICADE

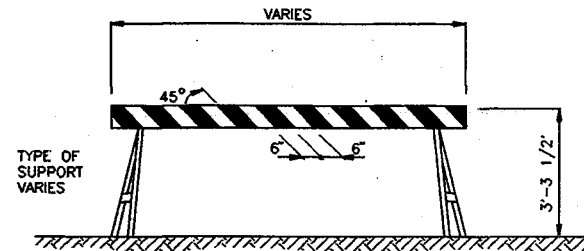

TYPE I BARRICADE

STRIPE NOTES:

ORANGE & WHITE IF TEMPORARY.
RED & WHITE IF PERMANENT.
REFLECTORIZED
SLANT DOWNWARD, RIGHT OR LEFT,
IN DIRECTION TRAFFIC WILL PASS.
SLANT BOTH DIRECTIONS FROM MIDDLE
IF TRAFFIC PASSES BOTH ENDS.
WIDTH 6" EXCEPT 4" IF RAILS ARE
LESS THAN 3' LONG.
SLANT DOWNWARD TO MIDDLE AT END
OF CLOSED ROAD.

SEE SEC. 5.07 AND MUTCD SEC.6C-8.

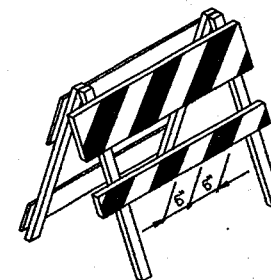

TYPE II BARRICADE

BARRICADE NOTES:			
TYPE	I	II	III
WIDTH OF RAIL	8" MIN. 12" MAX.	8" MIN. 12" MAX.	8" MIN. 12" MAX.
LENGTH OF RAIL	2' MIN.	2' MIN.	4' MIN.
HEIGHT	3' MIN.	3' MIN.	5' MIN.
TYPE OF FRAME	DEMOUNTABLE OR HEAVY "A"	LIGHT "A" FRAME	POST OR SKIDS
FLEXIBILITY	ESSENTIALLY MOVABLE	PORTABLE	ESSENTIALLY PERMANENT

NOTE:
FOR DIMENSIONS NOT
SHOWN, SEE TABLE.



KING COUNTY PUBLIC WORKS
KING COUNTY, WASHINGTON

BARRICADES

DWG. 5-003
NO.

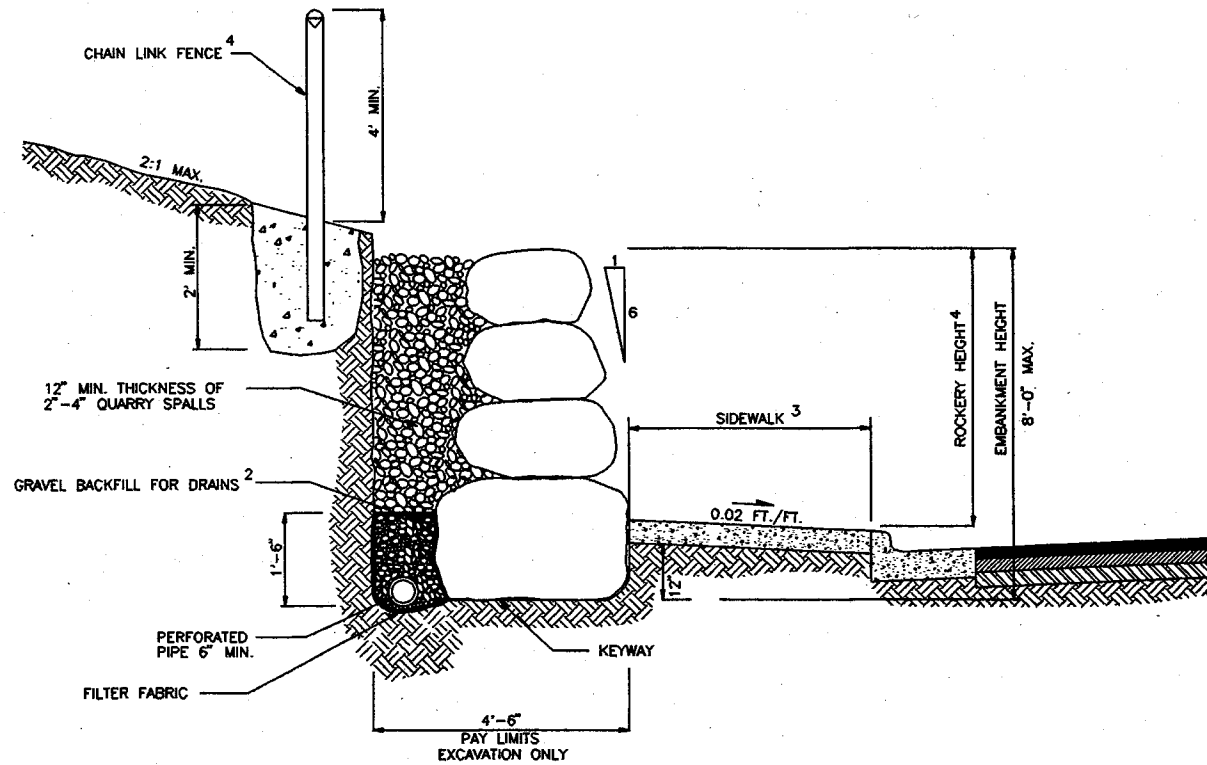

NOTES:

1. SEE SEC. 5.01.
2. WSDOT/APWA 9-03.12[4]
3. IF ROCKERY OR RETAINING WALL IS BEHIND ROLLED CURB OR ON A RURAL SECTION, FACE OF ROCKERY OR RETAINING WALL MUST BE A MIN. OF 10' FROM TRAVELED WAY.
4. CHAIN LINK FENCE, TYPE NO. 4 OR 6 (WSDOT/APWA STANDARD), REQUIRED WHEN ROCKERY HEIGHT IS THREE FEET OR GREATER.



KING COUNTY PUBLIC WORKS
KING COUNTY, WASHINGTON

ROCK FACING, CUT SECTION

DWG. NO. 5-004

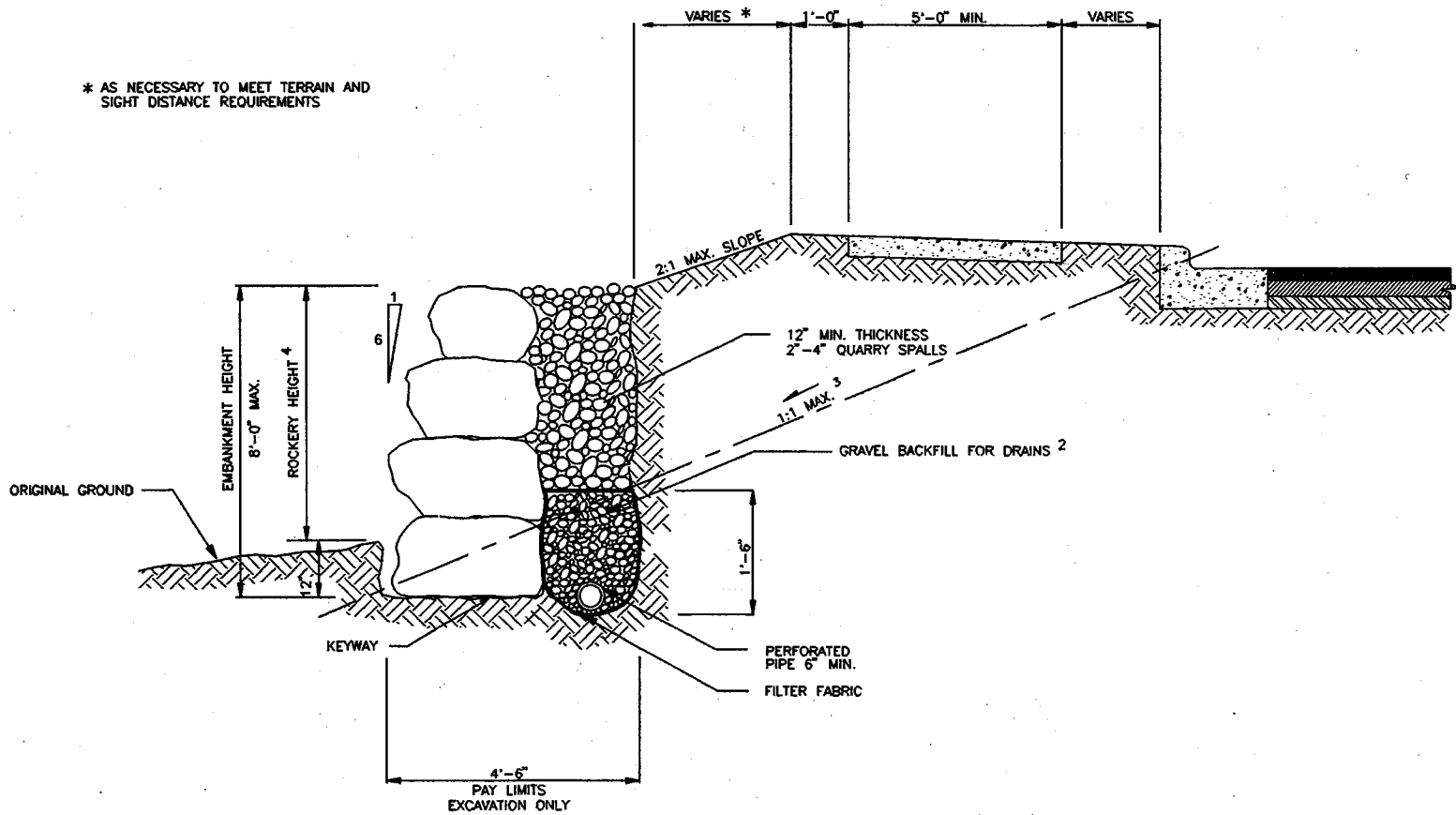

NOTES:

1. SEE SEC. 5.01.
2. WSDOT/APWA 9-03.12[4].
3. FLATTER SLOPE MAY BE REQUIRED IN LESS STABLE SOIL.
4. CHAIN LINK FENCE, TYPE NO. 4 (WSDOT/APWA STANDARD) OR HANDRAIL REQUIRED WHEN ROCKERY HEIGHT IS 3' OR GREATER. SEE DWG. NO. 5-006.
5. FOR ROCKERY HEIGHTS EXCEEDING 4', SEE DWG. NO. 5-007.
6. TRAFFIC BARRIERS MAY BE REQUIRED ON ROADS WITH SPEED LIMITS OF 40 MPH OR GREATER, WHERE ROCKERY HEIGHTS EXCEED 6'. SEE CHAPTER 7 OF THE WSDOT DESIGN MANUAL.



KING COUNTY PUBLIC WORKS
KING COUNTY, WASHINGTON

ROCK FACING, FILL SECTION

DWG. NO. 5-005

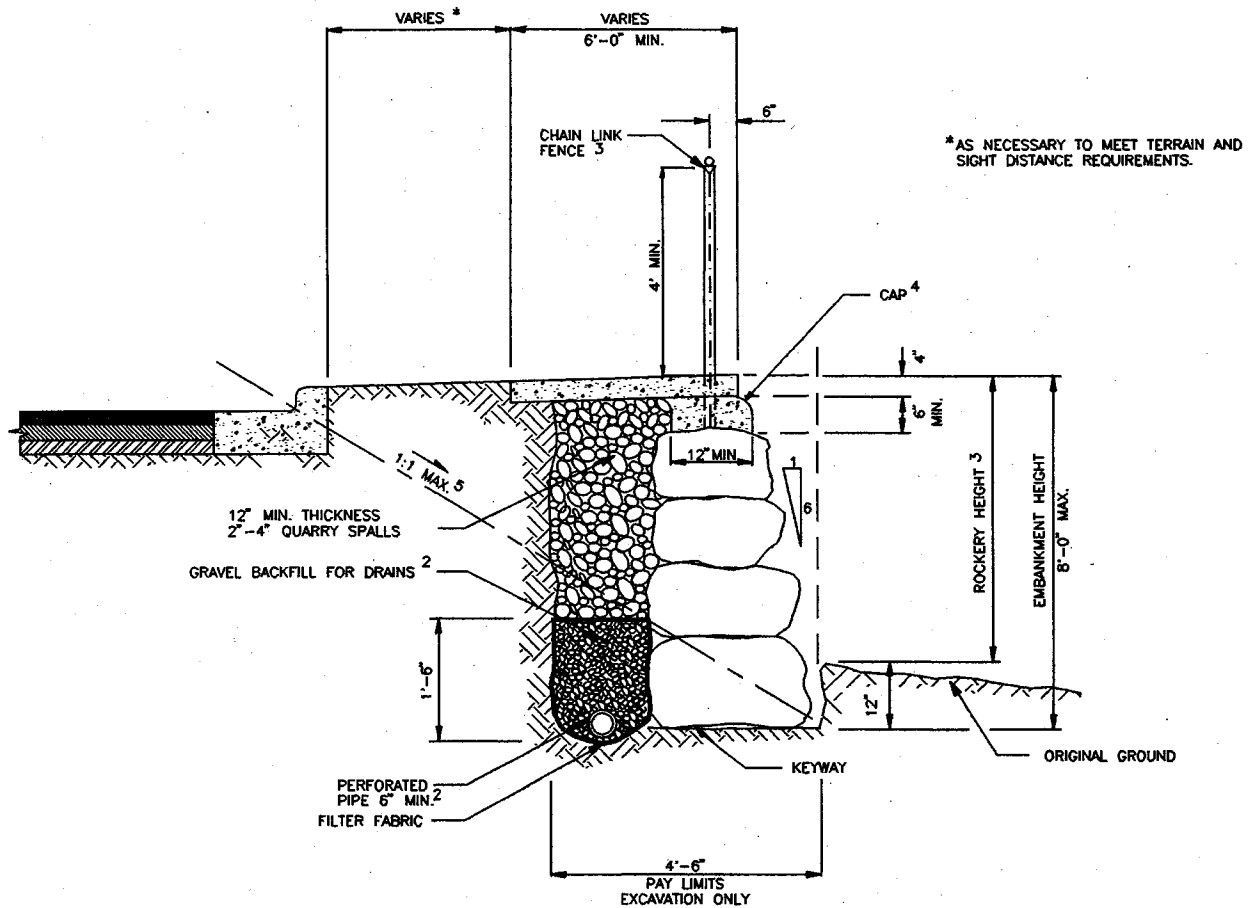

*AS NECESSARY TO MEET TERRAIN AND SIGHT DISTANCE REQUIREMENTS.

NOTES:

1. SEE SEC 5.01.
2. WSDOT/APWA 9-03.12[4].
3. CHAIN LINK FENCE, TYPE NO. 4 (WSDOT/APWA STANDARD) OR HANDRAIL REQUIRED WHEN ROCKERY HEIGHT IS 3' OR GREATER.
4. CAP SHALL BE CONCRETE CLASS 3000.
5. FLATTER SLOPE MAY BE REQUIRED IN LESS STABLE SOILS.
6. FOR ROCKERY HEIGHTS EXCEEDING 4', SEE DWG. NO. 5-007.
7. TRAFFIC BARRIERS MAY BE REQUIRED ON ROADS WITH SPEED LIMITS OF 40 MPH OR GREATER, WHERE HEIGHTS EXCEED 6'. SEE CHAPTER 7 OF THE WSDOT DESIGN MANUAL.



KING COUNTY PUBLIC WORKS
KING COUNTY, WASHINGTON

ROCK FACING UNDER SIDEWALK

DWG. 5-006
NO.

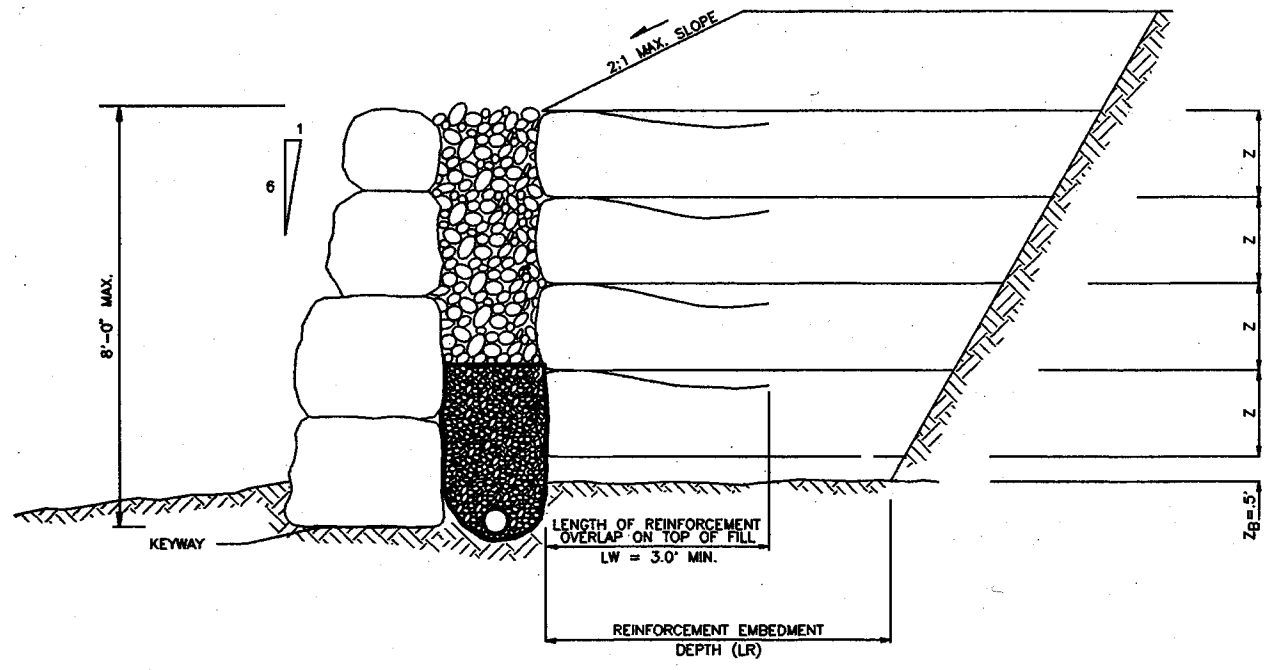

NOTES:

1. ROCKERY FACINGS ARE TO BE CONSTRUCTED TO KING COUNTY ROAD STANDARDS. SEE SEC. 5.01 AND DWGS. NO. 5-004 THROUGH 5-006.
2. THE WALL FOUNDATION IS TO BE CLEARED OF ORGANIC MATTER AND DEBRIS AND THE UNDERLYING MINERAL SOIL COMPACTED TO 95 PERCENT OF THE MAX. DRY DENSITY. THE EMBANKMENT MATERIAL IS TO BE GRAVEL BORROW MEETING THE REQUIREMENTS OF 9-03.14 OF THE WSDOT STANDARDS. THE BACKFILL IS TO BE PLACED IN THIN LIFTS, NOT EXCEEDING SIX INCHES IN THICKNESS AND COMPACTED TO 95 PERCENT OF THE MAX. DRY DENSITY.
3. GEOSYNTHETIC FABRIC OR GEOGRID REQUIREMENTS INCLUDING TYPE, VERTICAL SPACING (Z), AND EMBEDMENT (LR), WILL BE DETERMINED ON A ROCKERY BY ROCKERY BASIS BY A PROFESSIONAL ENGINEER.
4. Z_B IS HEIGHT OF FIRST LAYER OF REINFORCEMENT ABOVE COMPACTED SUBGRADE ELEVATION.
5. EMBANKMENTS BEHIND ROCKERIES EXCEEDING 4' IN HEIGHT SHALL BE REINFORCED WITH GEOSYNTHETIC FABRIC OR GEOGRID.

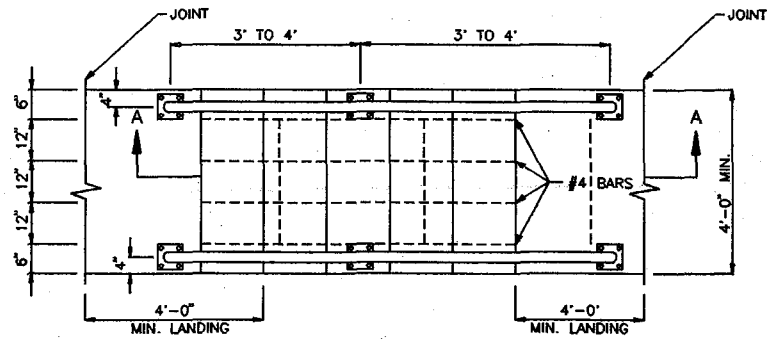

CONCRETE STEPS
PLAN

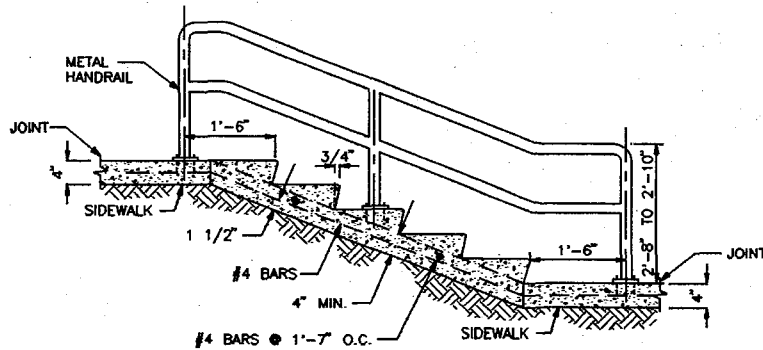

CONCRETE STEPS
SECTION A-A

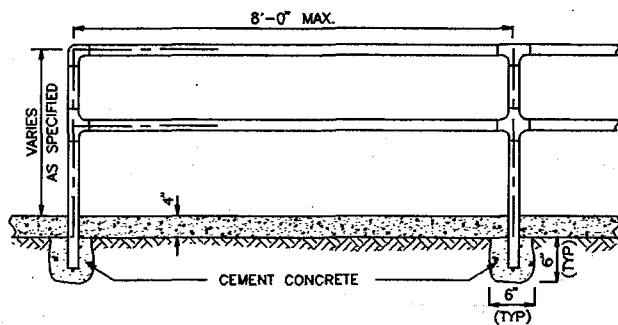

METAL HANDRAIL

CEMENT CONCRETE
SIDEWALK

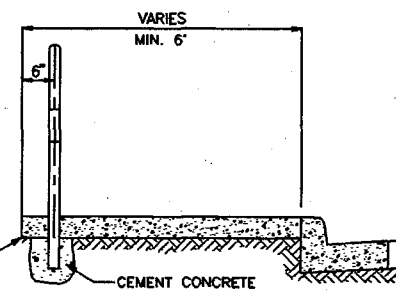

CEMENT CONCRETE

NOTES FOR CONCRETE STEPS:

1. CONCRETE: CEMENT CONCRETE CLASS 3000.
2. ALL STEPS: SAME DIMENSIONS, WITHIN 3/8" MAX. DIFFERENCE.
3. RISERS: 7 1/2" MAX., 5" MIN.
4. TREADS: 12" MAX., 11" MIN., WITH TRANSVERSE 0.01 FT./FT. SLOPE.
5. METAL HANDRAIL REQUIRED FOR 4 STEPS OR MORE. SEE NOTES BELOW.
6. REINFORCING BARS SHALL MEET THE REQUIREMENTS OF ASTM A-615, GRADE 60 AND ARE REQUIRED FOR 4 STEPS OR MORE.
7. SEE SEC. 3.06.
8. MAX. VERTICAL DISTANCE BETWEEN LANDINGS IS 12'.

NOTES FOR HANDRAILS:

1. GALVANIZED STEEL OR ALUMINUM.
2. 1 1/4" TO 2" O.D. ROUND OR OVAL PIPE.
3. WELDED, WITH SMOOTH SURFACE AND JOINTS.
4. POSTS SET IN MIN. 6" CONCRETE CLASS 3000.
5. SEE SEC. 3.06.



KING COUNTY PUBLIC WORKS
KING COUNTY, WASHINGTON

CONCRETE STEPS & METAL HANDRAIL

DWG. 5-008
NO.

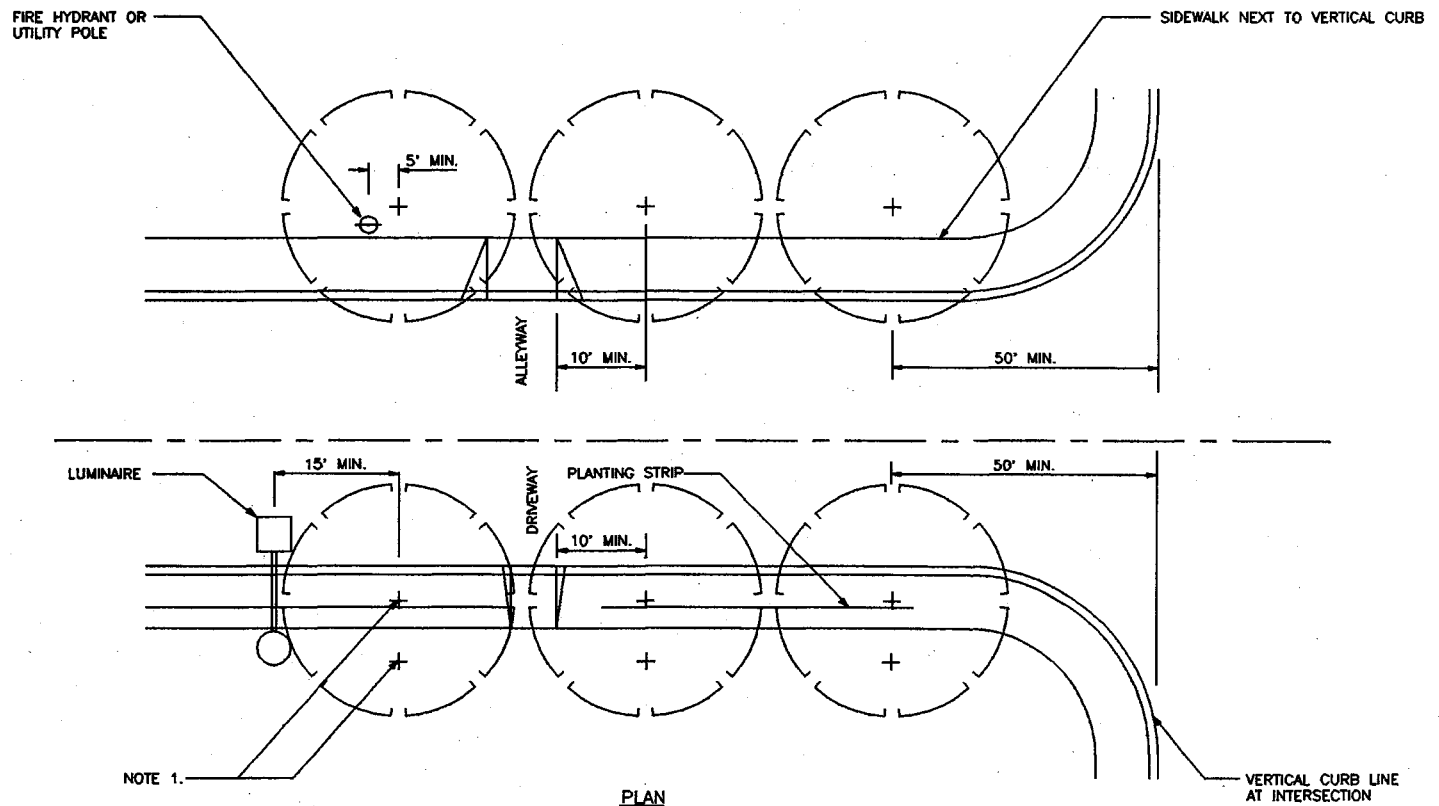

NOTES:

1. TREES SHALL GENERALLY BE PLANTED BACK OF THE SIDEWALK. PLANTING STRIPS WILL BE APPROVED ONLY AS PART OF A LANDSCAPING PLAN IN WHICH PLANT MAINTENANCE, COMPATIBILITY WITH UTILITIES, AND TRAFFIC SAFETY ARE DULY CONSIDERED.
2. IF PLANTING STRIPS ARE APPROVED:
 - A. MIN. DISTANCE FROM CENTER OF ANY TREE TO NEAREST EDGE OF VERTICAL CURB SHALL BE 4 FEET.
 - B. TREES SHALL BE STAKED IN A MANNER NOT TO OBSTRUCT SIDEWALK TRAFFIC.
 - C. IN CASE OF BLOCK-OUTS, MIN. CLEAR SIDEWALK WIDTH SHALL BE 5 FEET IN RESIDENTIAL OR 8 FEET IN BUSINESS DISTRICTS.
3. ON BUS ROUTES, PLANS SHALL BE COORDINATED WITH METRO SERVICE PLANNING. PHONE 684-1622.
4. SEE SEC. 5.03.



KING COUNTY PUBLIC WORKS
KING COUNTY, WASHINGTON

STREET TREE STANDARDS

DWG. 5-009
NO.

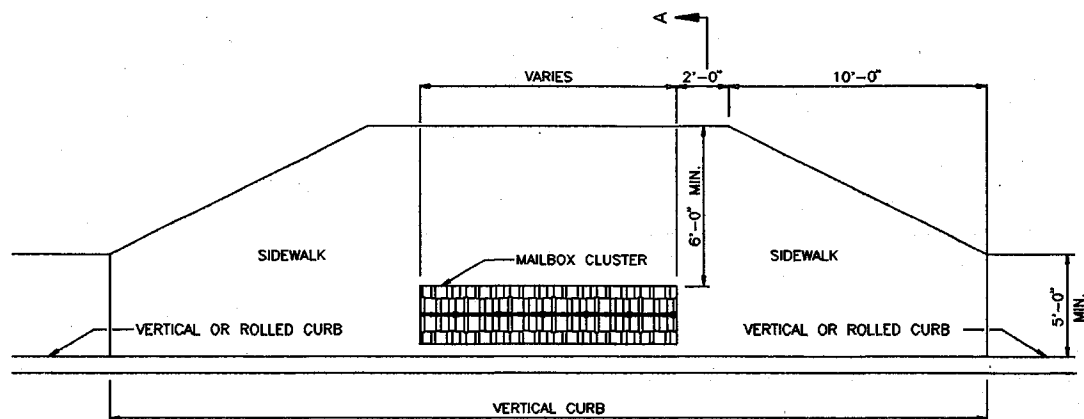

PLAN

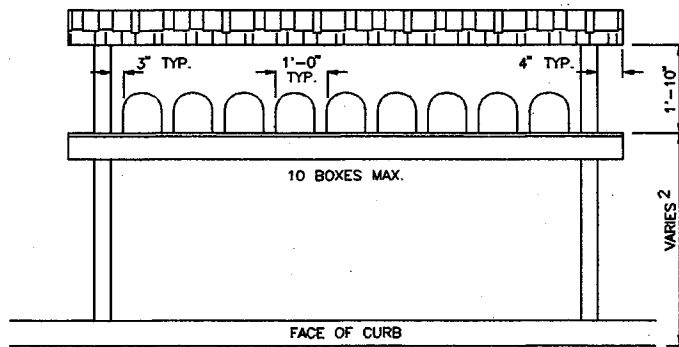

ELEVATION

NOTES:

1. FOR THREE OR MORE MAILBOXES ON URBAN RESIDENTIAL ACCESS STREETS WHERE THE SPEED LIMIT IS 25 MPH.
2. MAILBOX HEIGHT VARIES ACCORDING TO THE TYPE OF DELIVERY VEHICLE. THESE HEIGHTS SHALL BE DETERMINED BY THE POSTMASTER DURING PLAN REVIEW.
3. MAILBOXES MUST BE POSTMASTER APPROVED WITH A UNIFORM BOX STYLE AND METHOD OF ADDRESS IDENTIFICATION.
4. LOCATION OF MAILBOXES SUBJECT TO APPROVAL OF THE REVIEWING AGENCY.
5. WOOD POSTS SHALL BE PRESSURE TREATED FIR OR HEMLOCK.
6. FOR MAILBOX CLUSTER LOCATION IN SHOULDER SECTION SEE DWG. NO. 5-011
7. SEE SEC. 5-04.
8. OPTIONAL NEWSPAPER BOX STRUCTURES ARE SUBJECT TO APPROVAL OF REVIEWING AGENCY.

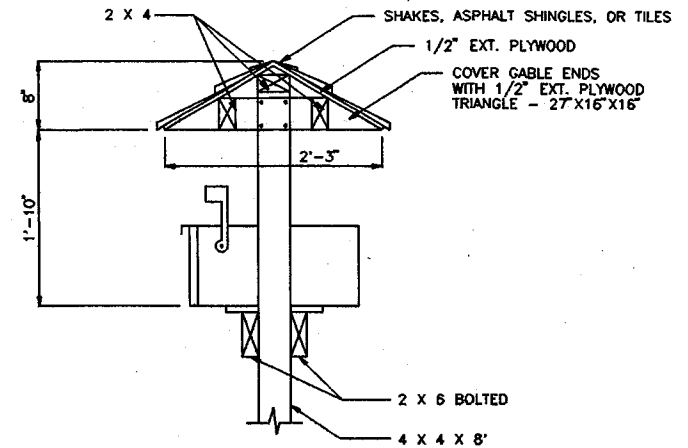

DETAIL

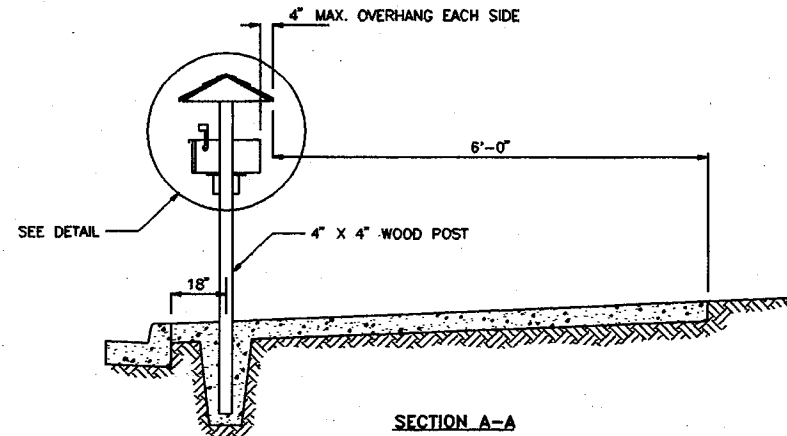

SECTION A-A



KING COUNTY PUBLIC WORKS
KING COUNTY, WASHINGTON

MAILBOX MOUNTING CURB TYPE LOCATION

DWG. NO. 5-010

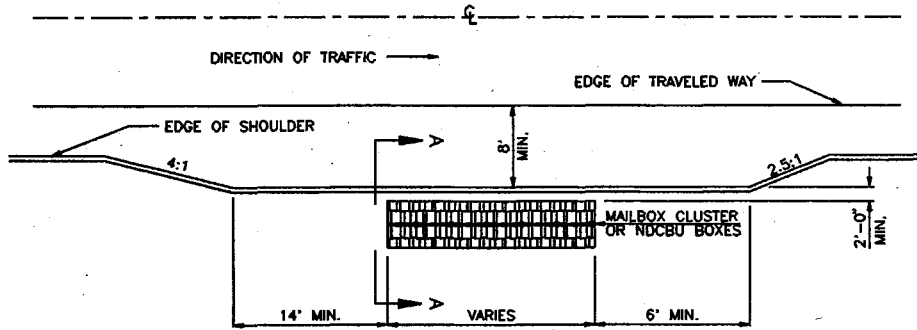

MAILBOX TURNOUT
FOR SHOULDER WIDTHS LESS THAN 8'-0" ³

PLAN

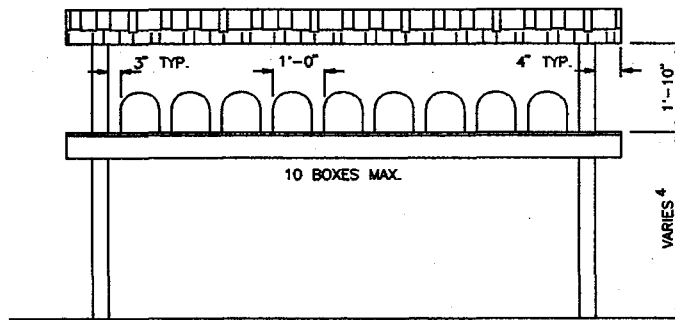

ELEVATION

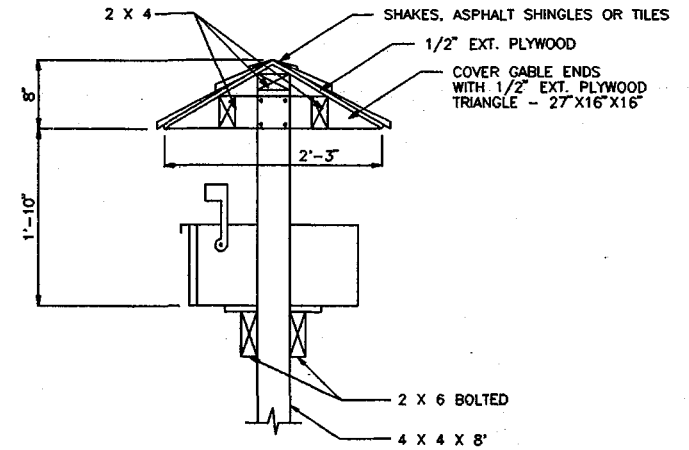

DETAIL

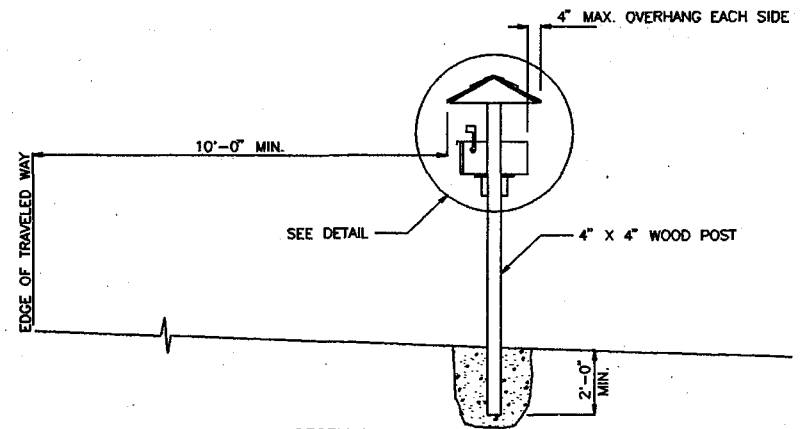

SECTION A-A

NOTES:

1. SEE SEC. 5.04.
2. MAILBOX INSTALLATIONS ON PROJECTS FUNDED BY FEDERAL GRANTS SHALL BE CONSTRUCTED IN ACCORDANCE WITH WSDOT/APWA STANDARD PLAN H-12.
3. REVIEWING AGENCY MAY APPROVE INSTALLATIONS OF MAILBOXES WITHOUT TURNOUT IF CONSTRUCTED IN CONFORMANCE WITH WSDOT/APWA STANDARD PLAN H-12.
4. MAILBOX HEIGHT VARIES ACCORDING TO THE TYPE OF DELIVERY VEHICLE. THESE HEIGHTS SHALL BE DETERMINED BY THE POSTMASTER DURING PLAN REVIEW.



KING COUNTY PUBLIC WORKS
KING COUNTY, WASHINGTON

MAILBOX MOUNTING SHOULDER TYPE LOCATION

DWG. NO. 5-011

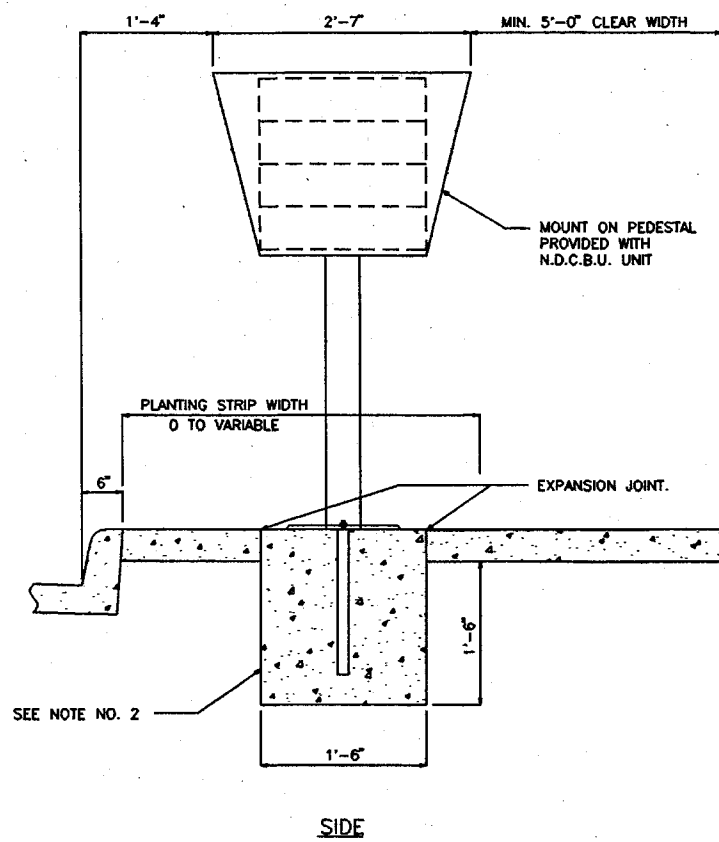
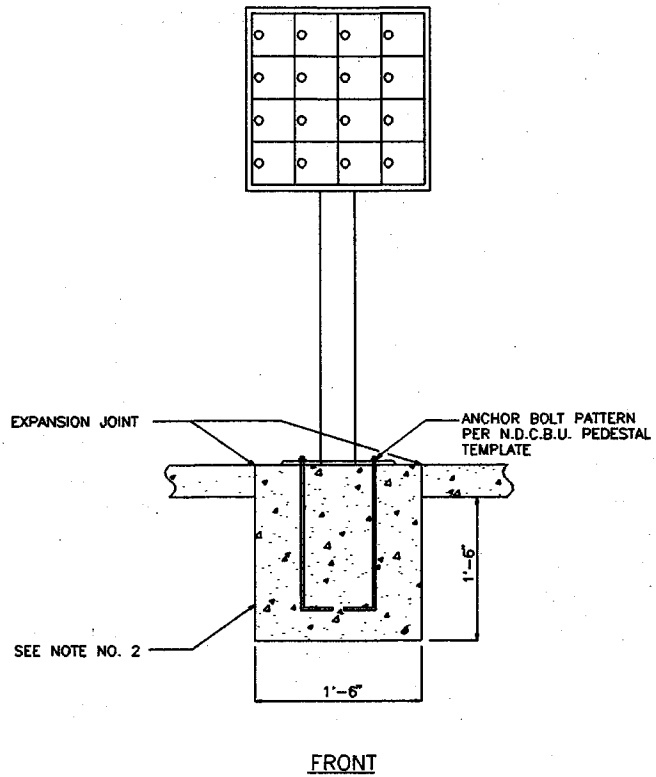

NOTES:

1. SEE SEC. 5.04.
2. INSTALLATION OF N.D.C.B.U. (INCLUDING CONSTRUCTION OF BASE) WILL BE DONE BY U.S. POSTAL SERVICE.
3. SEE SEC. 3.04 FOR JOINT REQUIREMENTS.



KING COUNTY PUBLIC WORKS
KING COUNTY, WASHINGTON

NEIGHBORHOOD DELIVERY & COLLECTION BOX UNIT
(N.D.C.B.U.) MAILBOX INSTALLATION

DWG. 5-012
NO.

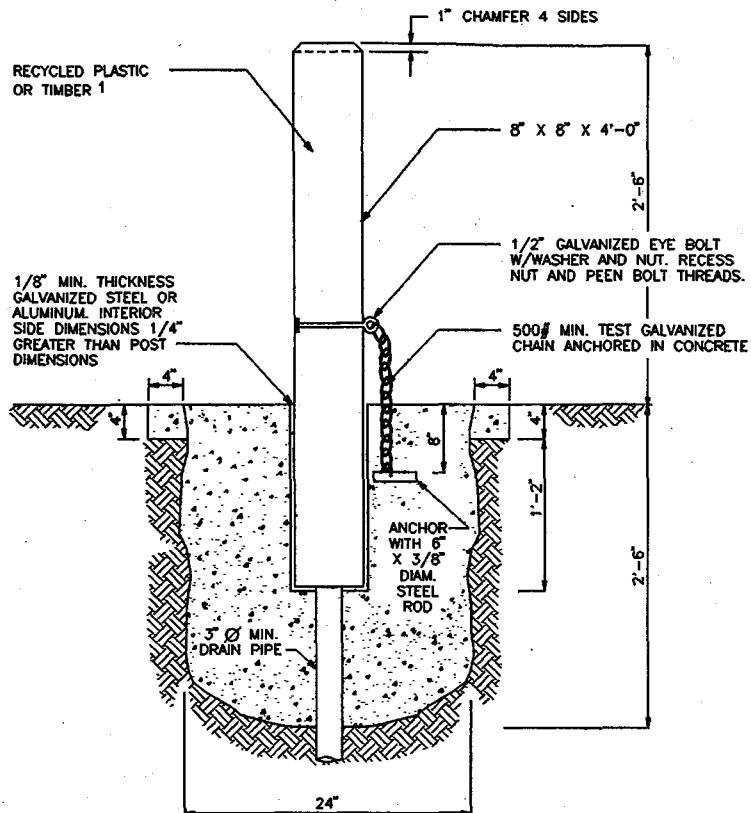

REMOVABLE BOLLARD
SECTION A-A

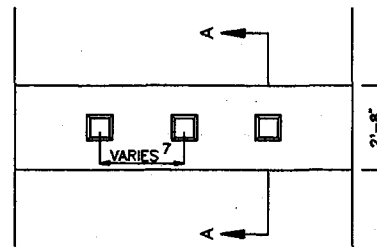

REMOVABLE BOLLARD
PLAN

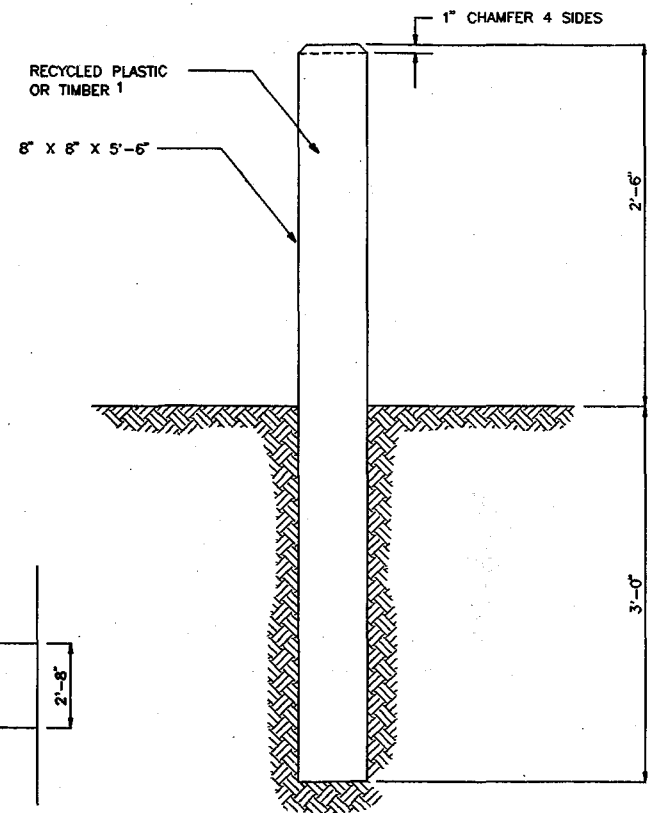

FIXED BOLLARD

NOTES:

1. RECYCLED PLASTIC BOLLARD SHALL BE WHITE. TIMBER SHALL BE DOUGLAS FIR, DENSE CONSTRUCTION GRADE, AND SHALL BE PRESSURE TREATED WITH A WATERBORNE PRESERVATIVE (ACA, CCA, ACZA) IN ACCORDANCE WITH THE REQUIREMENTS OF SEC. 9-09.3 (4) OF THE WSDOT/APWA STANDARD SPECIFICATIONS. TOP 5" OF TIMBER SHALL BE PAINTED WHITE.
2. STEEL TUBE SHALL CONFORM TO ASTM A53 GRADE A.
3. NUTS, BOLTS, & WASHERS SHALL CONFORM TO ASTM A307.
4. ALL STEEL PARTS SHALL BE GALVANIZED.
5. CONCRETE SHALL BE CLASS 3000.
6. SEE SEC. 5.08.
7. MIN. 50" SPACING ON TRAILS LESS THAN 10' WIDE. 60" SPACING ON TRAILS 10' OR WIDER.



KING COUNTY PUBLIC WORKS
KING COUNTY, WASHINGTON

BOLLARDS

DWG. 5-013
NO.

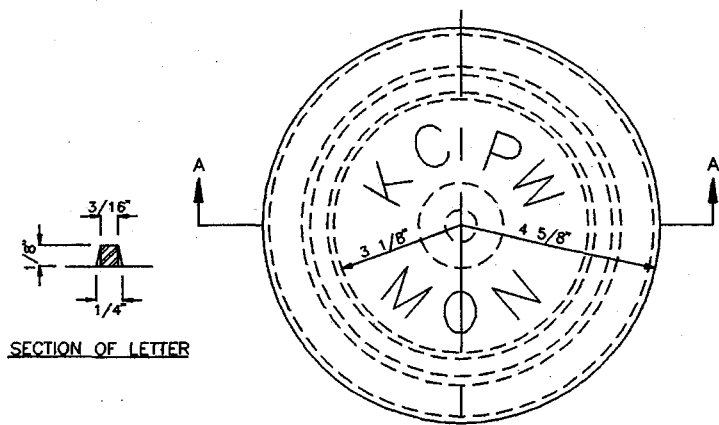

NOTES:

1. CASTINGS SHALL BE GRAY IRON ASTM A48, AASHTO M 105, CLASS 30.
2. COVER AND SEAT SHALL BE MACHINED FOR PERFECT CONTACT AROUND CIRCUMFERENCE AND FULL WIDTH OF BEARING SURFACE.
3. APPROXIMATE WEIGHTS, STANDARD.

CASE	60 LBS
COVER	19 LBS
TOTAL	79 LBS
4. PAVEMENT SHALL BE ASPHALT CONCRETE OR APPROVED SUBSTITUTE.
5. CONCRETE SHALL BE CLASS 4000.

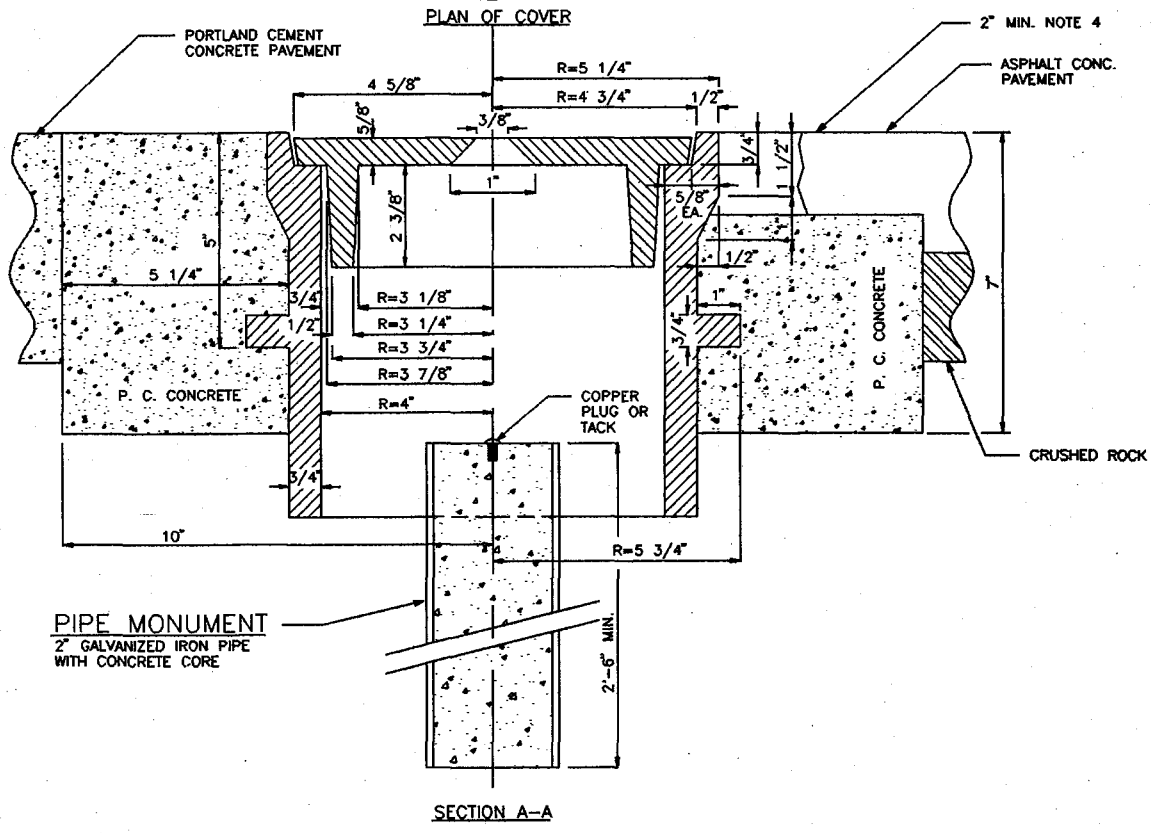
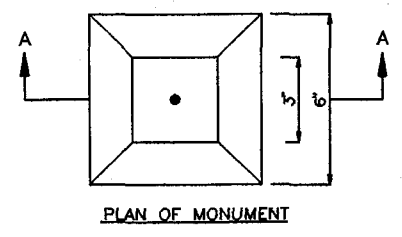

CONCRETE MONUMENT (ALTERNATE)

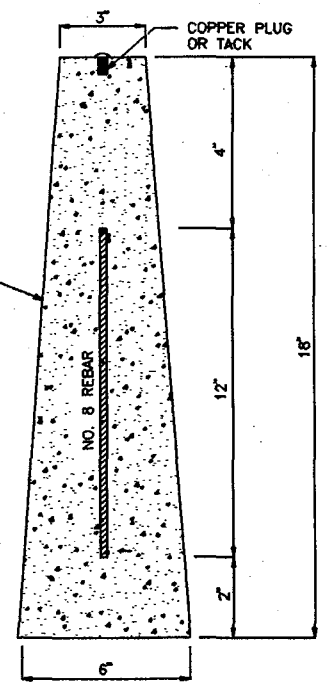

SECTION B-B



KING COUNTY PUBLIC WORKS
KING COUNTY, WASHINGTON

ROADWAY SURVEY MONUMENT WITH CASE & COVER

DWG. 5-014
NO.

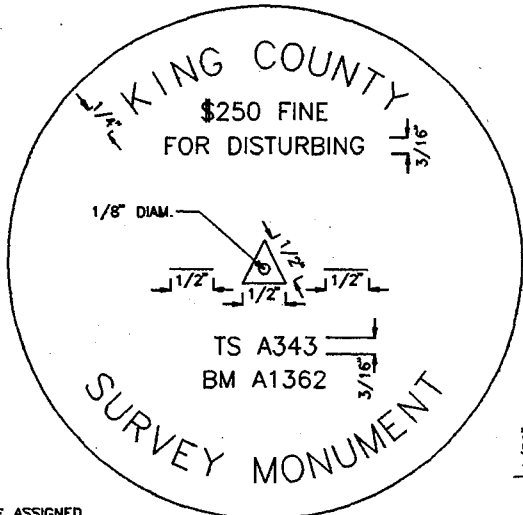

PLAN

NOTE:
ONLY THE ASSIGNED
IDENTIFICATION
NUMBERS
ARE TO APPEAR ON THE
BRASS DISC.

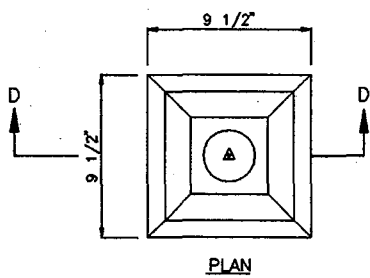
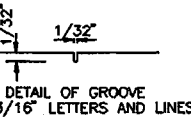
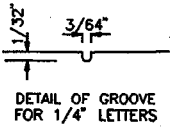

PLAN

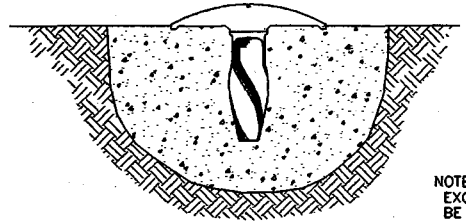

LEDGE ROCK OR
CONCRETE INSTALLATION

NOTE:
EXCAVATION TO
BE MADE LARGE
ENOUGH TO
CLEAR MARKER
1 1/2" AT
ALL POINTS.

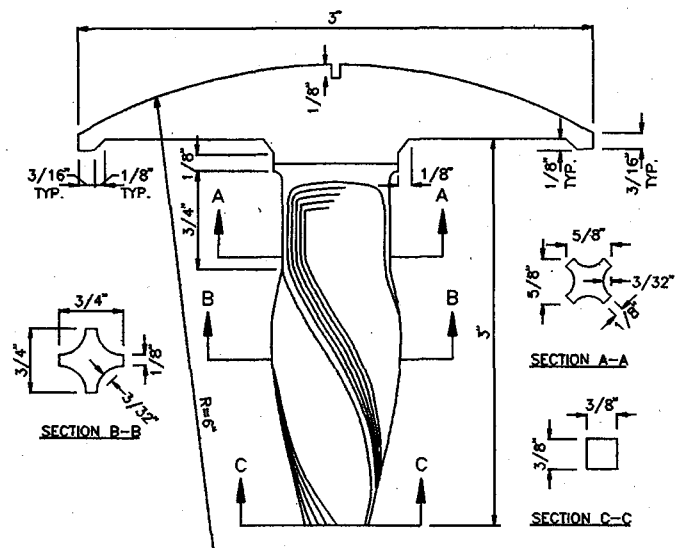

BRASS DISC
ELEVATION

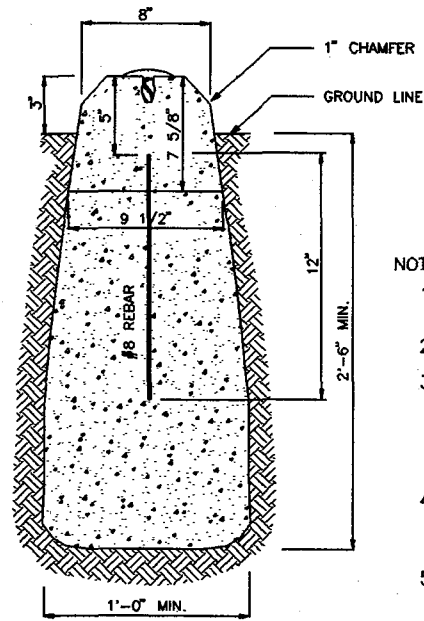

GENERAL INSTALLATION
SECTION D-D

NOTES:

1. THE BRASS DISC SHALL BE CAST OF YELLOW BRASS SAE 41.
2. CONCRETE SHALL BE CLASS 4000.
3. THE HOLE SHALL BE 2.5' MIN. IN DEPTH OR 0.5' BELOW THE DEEPEST RECORDED FROST LINE. ALL LOOSE MATERIAL SHALL BE REMOVED FROM THE BOTTOM OF THE HOLE SO THAT THE CONCRETE IS ON FIRM, UNDISTURBED EARTH.
4. THE TOP OF THE CONCRETE SHALL BE TROWLED SMOOTH AND THE BRASS DISC SET IN THE CENTER WITH ITS TOP EDGE FLUSH AND LEVEL.
5. COORDINATES OR ELEVATIONS SHALL NOT BE PLACED ON THE BRASS DISCS.



KING COUNTY PUBLIC WORKS
KING COUNTY, WASHINGTON

OFF-ROADWAY SURVEY MONUMENT

DWG. NO. 5-015

11187

ATTACHMENT B

2.03 RESIDENTIAL ACCESS STREETS [1]

Serving Single-Family Dev., see Drawings No. 1-001 through 1-006. For Multiple-Dwelling Dev., see Sec. 2.04, Commercial Access Streets.

CLASSIFICATION	LOCAL ACCESS STREETS							
	NEIGHBORHOOD COLLECTORS	SUBCOLLECTORS		SUBACCESS STREETS		MINOR ACCESS STREETS (RESIDENTIAL)		
FUNCTION	Streets connecting two or more neighborhoods and typically connecting to arterials or other neighborhood collectors.	Streets providing circulation within neighborhoods typically connecting to neighborhood collectors.		Permanent cul-de-sacs, or short loops [2], connecting to subcollectors and not supportive of through traffic.		Permanent cul-de-sacs or loops [2], with low traffic, providing circulation and access to off-street parking within residential development boundaries.		
Public or Private	Public streets	Public streets		Typically public streets For private streets (See Sec. 2.06.)		Public or private streets. (See Sec. 2.06.)		
Access	Restricted, Lots front on Local Access street where feasible.	As needed with some restrictions.		As needed with only minimal restrictions.		As needed with only minimal restrictions.		
Land Use Area	Rural	Urban	Rural	Urban	Rural	Urban	Rural	Urban
Serving Potential Number of Single-Family Dwelling Units	Over 100 [3]	Over 100 [3]	100 Max.	100 Max. [4]	50 Max.	50 Max.	16 Max.	16 Max.
CRITERIA								
A. Typical Road Type	Shoulder	Curb	Shoulder	Curb	Shoulder	Curb	Shoulder	Curb
B. Design Speed [5] (MPH)	35	35	30	30	Low Speed Curve See Sec. 2.10	Low Speed Curve See Sec. 2.10	Low Speed Curve See Sec. 2.10	Low Speed Curve See Sec. 2.10
C. Max. Superelevation (Ft./Ft.)	0.06	See Sec. 2.05B	0.06	See Sec. 2.05B	See Sec. 2.05B	See Sec. 2.05B	See Sec. 2.05B	See Sec. 2.05B
D. Horizontal Curvature Min. Radius (Ft.)	See Table 2.1	See Table 2.2	See Table 2.1	See Table 2.2	Low Speed Curve See Sec. 2.10	Low Speed Curve See Sec. 2.10	Low Speed Curve See Sec. 2.10	Low Speed Curve See Sec. 2.10
E. Max. Grade [6]	11	12	12	15	15	15	15	15
F. Standard Stopping Sight Distance (Ft.) [7]	See Table 2.1	See Table 2.2	See Table 2.1	See Table 2.2	150 ft.	150 ft.	150 ft.	150 ft.
G. Standard Entering Sight Distance (Ft.) [8]	See Table 2.1	See Table 2.2	-	-	-	-	-	-
H. Min. Pavement Width (Ft.)	22	32[9]	22	28	20	24	20[10]	22
I. Min. Roadway Width (Ft.) [11]	38	32[9]	38	28	28	24	28 [10]	22
J. Min. Right-of-Way Width (Ft.)	60	56	60	48[12]	48 [12]	40[12]	48 [12]	40[12]
K. Type of Curb or Shoulder and Ditch [11]	8' Shoulder & Ditch [13]	Vertical Curb & Gutter	8' Shoulder & Ditch [13]	Vertical or Rolled Curb & Gutter	4' Shoulder & Ditch [13]	Vertical or Rolled Curb & Gutter	4' Shoulder & Ditch [13]	Vertical or Rolled Curb & Gutter
L. Min. Half St. Paved Width (Ft.)	20	20	20	20	20	20	20	20
M. Min. One-Way Paved Width (Ft.)	20	20	20	20	20	20	20	20

N. NOTES:

- 1 - Within the above parameters, geometric design for specific streets shall be consistent with AASHTO Policy on Geometric Design of Highways and Streets.
- 2 - See Section 2.15 for one-way loops.
- 3 - See Section 2.20 for residential access connection requirements.
- 4 - See Section 2.21 for urban exception criteria.
- 5 - Design speed is a basis for determining geometric elements and does not imply posted or legally permissible speed. Curves shall be designed within parameters of B, C and D above. (See Section 2.05)
- 6 - Maximum grade may be exceeded for short distances. (See Section 2.11)
- 7 - Standard Stopping Sight Distance (SSD) shall apply unless otherwise approved by the Engineer. (See Section 2.12)
- 8 - Standard Entering Sight Distance (ESD) shall apply at intersections and driveways on neighborhood collectors unless otherwise approved by the Engineer (See Section 2.13)
- 9 - Neighborhood collectors intersecting with arterials shall be 36 feet wide for the first 150 feet. See Section 4.05 for tapers.
- 10 - Exception to paving requirement on minor access shoulder type streets: (See Section 2.17)
- 11 - For guardrail installation, shoulders shall be two feet wider.
- 12 - Right-of-way (or easement) may be reduced to minimum roadway width, plus sidewalks, provided that all potential serving utilities and necessary drainage are otherwise accommodated on permanent easements within the development. (See Section 2.19)
- 13 - As alternative to shoulder and ditch, underground pipe drainage with either Thickened Edge, Dwg. 1-005 or Extruded Curb, Dwg. 1-006 is acceptable.

11187

2.19 Slope, Wall, & Drainage Easements and Right-of-Way Reduction

A. Easements

Either the functional classification or particular design features of a road may necessitate slope, sight distance, wall or drainage easements beyond the right-of-way line. Such easements may be required by the Engineer or Reviewing Agency in conjunction with dedication or acquisition of right-of-way.

B. Right-of-way reduction on subcollectors, local access (residential) and minor access (commercial)

In proposed developments served by underground utilities within easements, the right-of-way may be reduced, as allowed in Sections 2.03 and 2.04, with the approval of the Reviewing Agency. Where it is desired to reduce right-of-way to a minimum width, the right-of-way, plus easement, shall allow for construction and maintenance of the following as appropriate, sidewalks, planter strips, drainage facilities, sign placement, and also allow sidewalk widening around mailbox locations. On subcollectors, installation of fixed objects, other than required above ground utility structures and landscaping contained in planter strips, greater than four inches in diameter within four feet of back of sidewalk shall not be permitted.

2.20 Access and Circulation Requirements

In order to provide a second access to a residential subdivision, short subdivision, binding site plan or planned unit development, no residential street shall serve more than 100 lots or dwelling units unless the street is connected in at least two locations with another street that functions at a level consistent with Sections 2.02 and 2.03.

A. The second access requirement may be satisfied through use of connecting a new street to an existing street in an adjacent neighborhood if:

1. No other practical alternative exists, or
2. Existing street was previously stubbed indicating intent for future access, or
3. An easement has been recorded specifically for said purpose.

The second access requirement may not be satisfied through use of an existing roadway network in the existing adjacent neighborhood if:

1. A more practical alternative exists, or
2. Existing streets do not meet Section 2.03

These provisions are not intended to preclude the state statute on land-locking.

B. This section does not preclude a commercial project from gaining access through a residential development. Traffic impacts for such projects will be analyzed during the SEPA process.

2.21 Exception for Maximum Dwelling Units on Urban Subcollectors

Proposed subcollectors serving new urban area developments with an average density of seven to eight dwelling units per acre and which meet the access requirements of Section 2.20 may serve up to 250 single-family dwelling units, if approved by the Reviewing Agency. Prior to approval, the Reviewing Agency may require a traffic circulation study showing a balanced traffic flow of less than 1500 vehicles per day past any access point. Street trees shall be mandatory along subcollectors serving higher densities of seven to eight dwelling units per acre and shall be in conformance with Section 5.03.

1118'

requirement will be based on traffic engineering analysis submitted by the applicant that considers, among other factors, intersection spacing, sight distance and traffic volumes.

- F. Notwithstanding any other provisions, driveways will not be allowed where they are prohibited by separate County Council action or where they are determined by the Engineer or Reviewing Agency to create a hazard or impede the operation of traffic on the roadway.

3.02 Concrete Sidewalks

- A. Shall be required on urban category, curb and gutter type streets as follows:

1. On all arterials, neighborhood collectors, subcollectors, multiple-dwelling and business access streets, both sides.
2. On subaccess streets and industrial access streets, one side.
3. On minor access streets (commercial), both sides unless alternative routes are provided for pedestrians.
4. On minor access streets (residential) exceeding 150 feet and on any cul-de-sacs with off-street walkways extending from their termini to other streets, parks, schools, bus stops, or other pedestrian traffic generators, one side. On cul-de-sacs, sidewalks shall extend around bulb to intersect off-street walkway. Other extended off-street walkways may be required by the Reviewing Agency to provide direct connections for ease and safety of pedestrians.

- B. Shall be constructed:

1. Next to the curb unless planting strips are part of the design and are approved by the Engineer as part of a landscaping plan.
2. Back of planting strips where planting strips are to be constructed.
3. At least five feet wide on residential and commercial access streets. This means five feet clear of mailboxes or other obstructions, except where approved as a variance. Width shall be minimum six and one-half feet on arterials if curb is next to traveled lane (but not necessary next to designated parking or bike lanes). The additional width, one and one-half feet or more, may be finished to match the sidewalk or may be finished with contrasting texture, asphalt concrete, brick, or paving blocks as approved by the Reviewing Agency or Engineer.
4. At least eight feet wide:
 - a. In business/commercial districts where most of the store frontage is within 80 feet of the street right-of-way.

11187

- b. Within the curb radius returns of all arterial intersections where curb ramps are required.
 - c. Within designated bus zones to provide a landing area for wheel chair access to transit services.
5. With specified width greater than eight feet where Engineer or Reviewing Agency determines this is warranted by expected pedestrian traffic volume.
6. With portland cement concrete surfacing as provided in Sections 3.03 and 4.01. See specifications for joints in Section 3.04 and Drawing No. 3-001.

3.03 Curbs, Gutters and Sidewalks

- A. Subgrade compaction for curbs, gutters, and sidewalks shall meet a minimum 90 percent of maximum density.
- B. Concrete for curbs, gutters, and sidewalks shall be Class 3000, furnished and placed in accordance with WSDOT/APWA Standard Specifications, Sections 6-02, 8-04, and 8-14. Cold weather precautions as set forth in WSDOT/APWA Standard Specifications Sections 5-05.3(14) and 6-02.3(6)A shall apply.
- C. Extruded cement concrete curb shall be anchored to existing pavement by either steel tie bars or adhesive in conformance with WSDOT/APWA Standard Specification Section 8-04.
- D. Extruded asphalt curbs shall be anchored by means of a tack coat of asphalt in accordance with WSDOT/APWA Standard Specification Section 8-04.

3.04 Expansion and Dummy Joints. See Drawing No. 3-001.

- A. An expansion joint consisting of 3/8" or 1/4" x full depth of premolded joint material shall be placed around fire hydrants, poles, posts, and utility castings and along walls or structures in paved areas. Joint material shall conform to the requirements of ASTM D994 (AASHTO M33).
- B. A dummy joint consisting of 3/8" or 1/4" x 2" of premolded joint material shall be placed in curbs and sidewalks at a minimum of 15 foot intervals and at sides of drainage inlets. When curbs and/or sidewalks are placed by slip-forming, a premolded strip up to 1/2" thick and up to full depth may be used.
- C. Dummy joints in sidewalk shall be located so as to match the joints in the curb whether sidewalk is adjacent to curb or separated by planting strip.
- D. Tool marks consisting of 1/4" V-grooves shall be made in sidewalk at five foot intervals, intermediate to the dummy joints.

5.02 Side Slopes

- A. Side slopes shall generally be constructed no steeper than 2:1 on both fill slopes and cut slopes. Steeper slopes may be approved by the Engineer upon showing that the steeper slopes, based on soils analyses, will be stable. Side slopes on projects funded by federal grants shall be constructed in conformance with Local Agency Guidelines.
- B. Side slopes shall be stabilized by grass sod or seeding or by other planting or surfacing materials acceptable to the Engineer.

5.03 Street Trees & Landscaping

- A. Street trees and landscaping should be incorporated into the design of road improvements for all classifications of roads. Such landscaping in the right-of-way shall be coordinated with off-street landscaping required on developer's property under the provisions of King County Code Chapter 21.51.
- B. Planting strips are optional along all classifications of roads and may be considered as part of the landscape mitigation requirements established during the SEPA review process. The design of planting strips must be approved by the Engineer and must include a landscaping plan in which plant maintenance, utilities and traffic safety requirements are discussed.
- C. Existing trees and landscaping shall be preserved where desirable and placement of new trees shall be compatible with other features of the environment. In particular, maximum heights and spacing shall not conflict unduly with overhead utilities, or root development with underground utilities. If street trees are planted, they shall conform reasonably to standards in Drawing No. 5-009.
- D. New trees shall not include poplar, cottonwood, soft maples, gum, any fruit bearing trees or any other tree or shrub whose roots are likely to obstruct sanitary or storm sewers. See King County Code 13.04.230.
- E. Street tree plans on bus routes shall be reviewed by Metro Service Planning, phone 684-1622.

5.04 Mail Boxes

- A. The responsibilities for location and installation of mailboxes in connection with the construction or reconstruction of County roads are as follows:
 - 1. County Road Engineer or his representative will:
 - a. Require road improvement plans, whether for construction by the Department of Public Works or by a private builder, to show clearly the designated location or relocation of mailboxes, whether single or in clusters.

openings that will discourage public entry. Where job site access is provided through the Type III barricades, the developer/contractor shall assure proper closure at the end of each working day.

- C. In the general case, Type III permanent barricades shall be installed to close arterials or other through streets hazardous to traffic. They shall also be used to close off lanes where tapers are not sufficiently delineated.
- D. Type III barricades shall be used at the end of a local access street terminating abruptly without cul-de-sac bulb or on temporarily stubbed off streets. Each such barricade shall be used together with an end-of-road marker.

5.08 Bollards

When necessary to deny motor vehicle access to an easement, tract, or trail, except for maintenance or emergency vehicles, the point of access shall be closed by a line of bollards. These shall include one or more fixed bollards on each side of the traveled way and removable, locking bollards across the traveled way. Spacing shall provide one bollard on centerline of trail and other bollards spaced at minimum 50 inches on center on trails 10 feet wide or less. Spacing shall be 60 inches on center on trails wider than 10 feet. Bollard design shall be in accordance with Drawing No. 5-013 or other design acceptable to the Engineer or Reviewing Agency. No fire apparatus access roads shall be blocked in this manner without the concurrence of the Fire Marshal. Bollards shall be located at least 10 feet laterally from the paved edge of roadway.

5.09 Guardrail/Embankment Heights

Guardrail installations shall conform to WSDOT/APWA Standard Plan C-1, Beam Guardrail Type 1 and C-2, Guardrail Placement. End anchors shall conform to WSDOT/APWA Standard Plan C-6, Beam Guardrail Anchor Type 1.

Evaluation of embankments for guardrail installations shall be in accordance with Figure 710-6 of the WSDOT Design Manual.

5.10 Off-Street Parking Spaces

The number of off-street parking spaces required shall conform to King County Code Title 21.50. The specifications for off-street parking spaces shall be as provided in King County Code Title 16.74 and implementing document entitled "King County Specifications for Off-Street Parking, 1982," as updated.

5.11 Roadside Obstacles

Non-yielding or non-breakaway structures, including rockeries and retaining walls, which may be potential hazards to the traveling public shall be placed with due regard to safety. On roads with a shoulder or mountable curb, hazardous objects shall be placed as close to the right-of-way line as practicable and a minimum of 10 feet from the edge of the traveled way or auxiliary lane. On urban roads with a vertical